

SAILOR

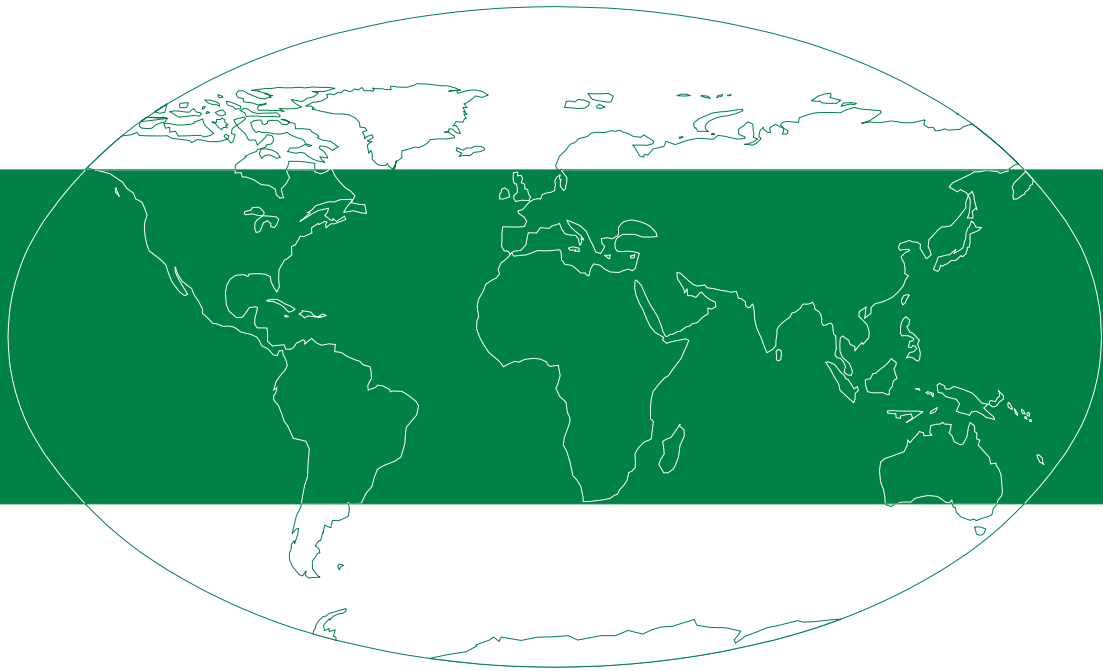

TECHNICAL MANUAL
FOR
SAILOR COMPACT HF SSB T2130



S.P. RADIO A/S · AALBORG · DENMARK



SAILOR[®] • Porsvej 2 • PO Box 7071 • DK-9200 Aalborg SV • Denmark
Phone: +45 9634 6100 • Fax: +45 9634 6101 • Telex: 69789 ECI DK
E-mail: sailor@sailor.dk • Web: www.sailor.dk

Please note

Any responsibility or liability for loss or damage in connection with the use of this product and the accompanying documentation is disclaimed.

The information in this manual is furnished for informational use only, is subject to change without notice, may contain errors or inaccuracies, and represents no commitment whatsoever.

This agreement is governed by the laws of Denmark.

Doc. no.: M2130GB

Issue: A/0129

CONTENTS

1	GENERAL INFORMATION	
1.1	INTRODUCTION	1-1
1.2	GENERAL DESCRIPTION	1-1
1.3	TECHNICAL DATA	1-2
1.4	PRINCIPLE OF OPERATION AND BLOCK DIAGRAM	1-4
2	INSTALLATION MECHANICAL HF SSB TRANSMITTER T2130	
2.1	MOUNTING POSSIBILITIES/DIMENSIONS AND DRILLING PLAN	2-1
2.1.1	INSTALLATION HINTS	2-4
2.2.2	BATTERY REQUIREMENTS FOR GMDSS	2-5
2.2.3	AERIAL AND RF GROUNDING REQUIREMENTS	2-7
2.2.4	MAIN CABLE PLANE WHEN SUPPLIED FROM 24V BATTERY.	2-11
2.2.5	MAIN CABLE PLANE WHEN SUPPLIED FROM 12V DC BATTERY, USING N2160 12V DC TO 24 V DC CONVERTER.	2-12
2.2.6	MAIN CABLE PLAN WHEN SUPPLIED FROM AC, USING N2161 AC TO 24V DC POWER SUPPLY. MAIN CABLE PLAN WHEN SUPPLIED BOTH FROM AC AND DC (N2161).	2-13
2.2.7	INSTALLATION WITH REMOTE CONTROL C2140	2-14
2.2.8	INSTALLATION WITH DSC (TELEX) RM2150	2-16
2.2.10	CONNECTIONS TO T2130	2-17
2.2.11	CONNECTIONS TO RE2100	2-18
2.2.12	CONNECTIONS TO AT2110	2-19
2.2.13	CONNECTIONS TO N2161	2-20
2.2.14	CONNECTIONS TO BATTERY CHARGER N2174	2-21
2.3	SYSTEM DESCRIPTION AND TROUBLE SHOOTING	2-23
2.3.3	SYSTEM FUNCTIONAL DESCRIPTION	2-24
3	SERVICE	
3.1	MAINTENANCE	3-1
3.2	ALIGNMENT INSTRUCTIONS	3-1
3.3	PROPOSAL FOR NECESSARY MEASURING INSTRUMENTS	3-1
3.4	TROUBLE SHOOTING	3-2
3.4.1	POWER AMPLIFIER (MODULE 1)	3-5
3.4.2	OUTPUT FILTER (MODULE 2)	3-6
3.4.3	TX-PROCESSOR (MODULE 3)	3-7
3.4.4	POWER SUPPLY (MODULE 4)	3-8
3.4.5	NOT USED	3-10
3.4.6	CONNECTION BOARD (MODULE 6)	3-10
3.4.7	REPLACEMENT OF COMPONENTS	3-10
3.4.8	REPLACEMENT OF MODULES	3-10
3.5	PERFORMANCE CHECK	3-11
3.5.1	POWER AMPLIFIER (MODULE 1)	3-12
3.5.2	OUTPUT FILTER (MODULE 2)	3-13
3.5.3	TX-PROCESSOR (MODULE 3)	3-14
3.5.4	POWER SUPPLY (MODULE 4)	3-19
3.5.5	NOT USED	3-20
3.5.6	CONNECTION BOARD (MODULE 6)	3-20
3.6	ADJUSTMENT PROCEDURE	3-21
97243.6.1	POWER AMPLIFIER (MODULE 1)	3-21

3.6.2	ADJUSTMENT OF OUTPUT FILTER (MODULE 2)	3-21
3.6.3	ADJUSTMENT OF DRIVE LEVEL	3-21
3.7	NECESSARY ADJUSTMENTS AFTER REPAIR	3-23
3.7.1	MODULES REPLACED	3-23
3.7.2	COMPONENTS REPLACED	3-24
3.8	FUNCTION CHECK	3-25
3.8.1	FUNCTION CHECK FOR THE TRANSMITTER INSTALLED	3-25
3.8.3	BATTERY CHECK	3-25
3.8.4	OUTPUT POWER CHECK	3-25
3.8.5	SWR CHECK	3-25
3.8.6	CHECK OF POWER GAIN IN PA-MODULE (1)	3-25
3.8.7	END OF SERVICE PROGRAMME	3-25
3.9	SERVICE PROGRAMMES	3-27
3.9.1	SERVICE PROGRAMMES IN T2130	3-27
3.9.2	SERVICE PROGRAMMES RELATED TO AT2110	3-32
4	MECHANICAL DISASSEMBLING	
4.1	MECHANICAL DISASSEMBLING AND MODULE LOCATION	4-1
5	CIRCUIT DESCRIPTION AND SCHEMATIC DIAGRAMS	
5.1	POWER AMPLIFIER (MODULE 1) PART NO. 625641	5-1
5.2	OUTPUT FILTER (MODULE 2) PART NO. 625642	5-2
5.3	TX-PROCESSOR (MODULE 3) PART NO. 625643	5-5
5.4	POWER SUPPLY I (MODULE 4) PART NO. 625644	5-7
5.6	COMPONENT LOCATION CONNECTION BOARD MODULE 6	5-28
5.9	INTERCONNECTION CABLE PLAN	5-31
6	PARTS LIST	

CONTENTS

1	GENERAL INFORMATION	
1.1	INTRODUCTION	1-1
1.2	GENERAL DESCRIPTION	1-1
1.3	TECHNICAL DATA	1-2
1.4	PRINCIPLE OF OPERATION AND BLOCK DIAGRAM	1-4

1 GENERAL INFORMATION

1.1 INTRODUCTION

The SAILOR Compact HF SSB T2130 is a 250W PEP SSB transmitter for the SAILOR Compact HF SSB Programme 2000.

SAILOR Compact HF SSB Programme 2000 is a powerful, advanced, high technology short wave communication system, which is extremely easy to operate.

It has been developed on the basis of S. P. Radio's many years of experience with short wave communication equipment.

It has the same high reliability as all SAILOR equipment is known for.

SAILOR HF SSB PROGRAMME 2000 CONSISTS OF THE FOLLOWING UNITS:

RE2100: Control unit with integral receiver and exciter.

T2130: 250W PEP SSB transmitter with integral power supply for RE2100.
Supply voltage 24V.

AT2110: 250W PEP aerial coupler for use outdoors.

N2160: 12V DC power supply for T2130.

N2161: 110/220/240V AC, 50 Hz power supply for T2130.

1.2 GENERAL DESCRIPTION

SAILOR HF SSB T2130 is an all solid state constructed microcomputer controlled SSB shortwave transmitter.

SAILOR HF SSB T2130 covers the frequency range from 1.6 MHz to 30 MHz.

SAILOR HF SSB T2130 has an output power of 250W PEP.

SAILOR HF SSB T2130 is constructed for continuous operation.

SAILOR HF SSB T2130 has 50 ohm output impedance.

SAILOR HF SSB T2130 is able to control the automatic aerial coupler AT2110.

SAILOR HF SSB T2130 has built-in power supply for 24V DC.

SAILOR HF SSB T2130 is able to supply the transceiver RE2100.

SAILOR HF SSB T2130 has built-in protection system, so that it will not be damaged if the aerial is open circuited or short-circuited.

1.3 TECHNICAL DATA**(complies with SOLAS, ITU, CEPT, MPT, DOC, FTZ, KSR, FCC)****GENERAL**

Frequency Range:	Receiver: 100 kHz to 30 MHz Transmitter: 1.6 MHz to 30 MHz
Modes:	J3E (USB/LSB), R3E and H3E (AM)
Channel Capacity:	100 user defined quick-select channels and ITU defined channels in the maritime bands. Each channel contains both RX and TX frequency and mode settings.
Scanning Facilities:	10 scanning programmes, each able to contain 128 pairs of frequencies.
Distress Call:	Quick selection of 2182 kHz Built-in two tone alarm: 1300 Hz and 2200 Hz with a duration of 45 secs.
Operating Temperature Range:	-15°C to +55°C
Frequency Stability:	Better than 0.34 ppm
Primary Voltage:	24V DC - 10% +30%
Current Drain:	Receiver (standby) 0.9A Transmit voice 7A Transmit two-tone 13A
Aerials:	from 7 - 15 m

TRANSMITTER T2130

Power Output:	250W PEP \pm 1.4 dB (T2130/I 240W PEP max.)
Intermodulation:	better than 32 dB below PEP
Spurious Emission:	better than 67 dB below PEP
Harmonics:	better than 43 dB below PEP or better than 67 dB below PEP with aerial coupler AT2110
Carrier Suppression:	better than 46 dB below PEP
Audio Response:	350 Hz to 2700 Hz at -6 dB

RECEIVER RE2100

Receive System:	Double conversion super heterodyne 1st IF 70 MHz. 2nd 10.73 MHz
Selectivity:	J3E (SSB) 350 Hz to 2700 Hz at -6 dB H3E (AM) \pm 3.3 kHz at -6 dB

Sensitivity:	J3E (SSB) <10 dB/uV for 20 dB SINAD H3E (AM) <24 dB/uV for 20 dB SINAD
Spurious and IF Rejection:	better than -70 dB
Cross Modulation:	better than 90 dB/uV (CEPT method of test)
Desensitization:	better than 100 dB/uV (CEPT method of test)
AGC:	less than 2 dB audio level change from 10 dB/uV to 80 dB/uV. Fast attack, slow release time.
Intermodulation:	better than 90 dB/uV (CEPT method of test)
Spurious Emission:	better than 1 nW into dummy aerial
Clarifier:	±150 Hz in steps of 10 Hz
Squelch:	Voice activated, opens for SINAD >6 dB
Audio Power:	5 Watt, 8 ohm, less than 10% distortion 10 Watt, 4 ohm, less than 10% distortion

AERIAL COUPLER AT2110

Power:	250W PEP
Aerials:	7 - 15m
Temperature Range:	-25°C to +70°C
Tuning Time:	Typically less than 2 secs (learn mode typ. 30 secs)

ACCESSORIES

Loudspeaker:	H2054 see special brochure H2074 see special brochure
Power Supplies:	N2160 Input supply: 12V + 30% - 10% For more information see the manual for N2160 N2161 Input supply: 110V - 127V - 220V - 240VAC Input frequency: 50 - 60 Hz For more information see the manual for N2161
Weight:	RE2100: 4.5 kg T2130: 14 kg AT2110: 4.5 kg

1.4 PRINCIPLE OF OPERATION AND BLOCK DIAGRAM

SAILOR Compact HF SSB T2130 is a 250W PEP transmitter in SAILOR Compact HF SSB Programme 2000. It contains following circuits.

POWER AMPLIFIER

The power amplifier is a push-pull amplifier.

The input signal from RE2100 is fed through a TX/RX switch on the output filter unit to the input of the power amplifier. The signal is amplified to approx. 280W PEP. The bias to the pre-driver, driver, and PA can be switched off from the TX microprocessor. When this is done, the output power will be attenuated more than 60 dB.

OUTPUT FILTER

The output filter consists of six lowpass filters, a directional coupler, a tune/transmit switch, and a TX/RX switch.

From the power amplifier the signal is fed to a lowpass filter, which attenuates all harmonics. Then the signal passes a directional coupler, which gives information about the standing wave ratio to the TX-processor unit.

After the directional coupler the signal is fed to a drive/transmit switch. In position drive the output power is fed to a 50 ohm load. This load is used to set the output power to the correct value.

After this switch the signal is fed to the TX/RX switch.

In position RX the signal from the aerial coupler AT2110 or the aerial is fed directly to RE2100.

In position TX the signal from RE2100 is fed to the input of the power amplifier and the output power is fed to the aerial coupler AT2110 or the aerial.

TX PROCESSOR

The processor takes care of controlling the power amplifier, output filters, aerial coupler AT2110, and communication with RE2100.

From RE2100 the TX-processor receives information about frequency and receive/transmit mode. The TX-processor gives information to RE2100 about tuning/tune ready and attenuator setting.

During tune-up the TX-processor is controlling the aerial coupler. It tunes for best standing wave ratio measured with the directional coupler on the output filter module.

During transmit the TX-processor is checking the temperature of the PA-transistors, supply voltage, and standing wave ratio. From these data the TX processor calculates the max. permissible power, and then sends this information to the RE2100, where the processor unit sets the attenuator in the exciter unit to the correct value.

POWER SUPPLY

This unit consists of two power supplies and the AF-amplifier.

The 24V DC is first fed to a relay which switches off/on the supply to the power supplies.

One switch mode power supply is used to generate $\pm 18V$ and 9V for all small signal circuits in T2130 and RE2100. The supply for the power amplifier and the AF-amplifier passes through a serial regulator, which limits the voltage to max. 28V.

CONNECTION BOARD

The connection board is the interface to the aerial coupler AT2110, HF SSB RE2100, 24V mains, and other units e.g. loudspeaker, muting of ext. receivers etc.

All input and output from ext. equipment are made through an optocoupler, a relay, or a transformer.

BLOCK DIAGRAM T2130

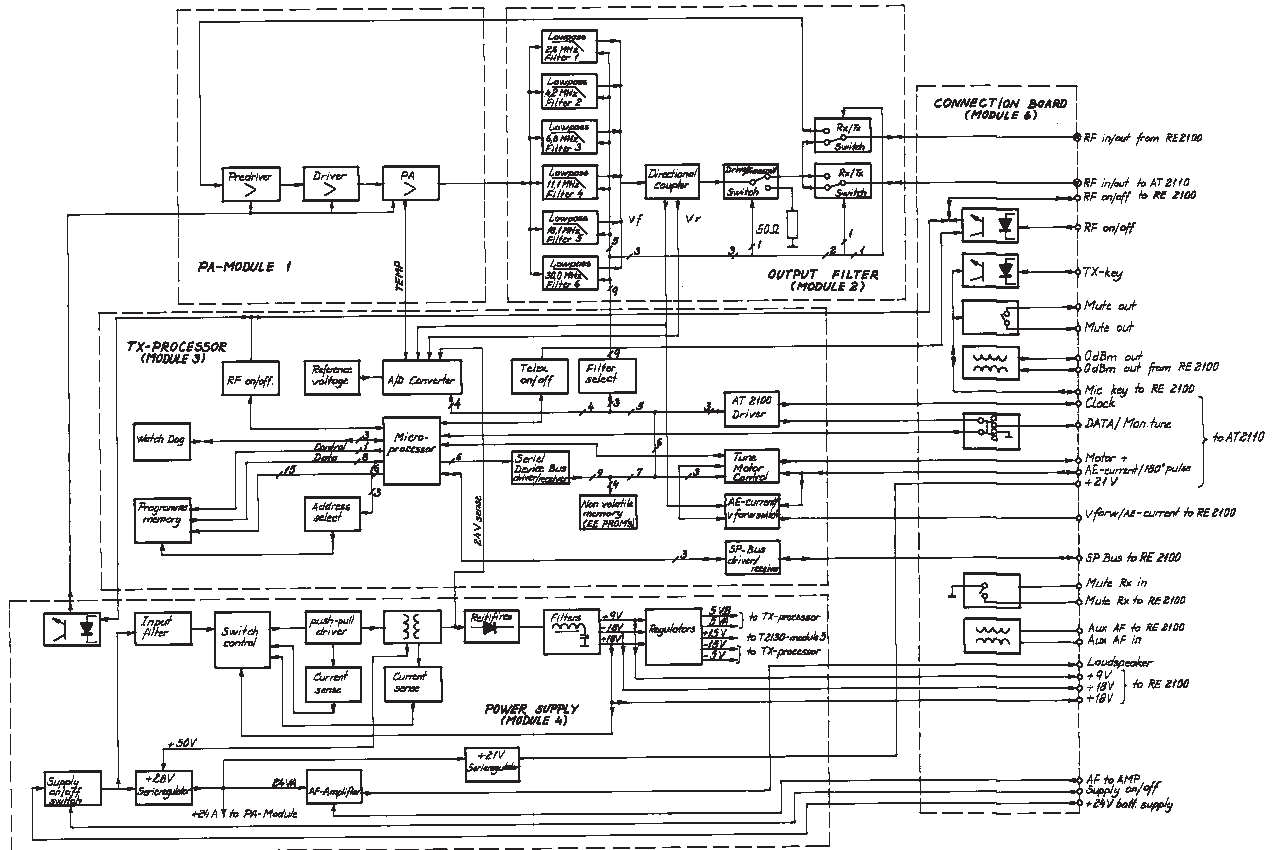

25888B

CONTENTS

2	INSTALLATION MECHANICAL HF SSB TRANSMITTER T2130	
2.1	MOUNTING POSSIBILITIES/DIMENSIONS AND DRILLING PLAN	2-1
2.1.1	INSTALLATION HINTS	2-4
2.2.2	BATTERY REQUIREMENTS FOR GMDSS	2-5
2.2.3	AERIAL AND RF GROUNDING REQUIREMENTS	2-7
2.2.4	MAIN CABLE PLANE WHEN SUPPLIED FROM 24V BATTERY.	2-11
2.2.5	MAIN CABLE PLANE WHEN SUPPLIED FROM 12V DC BATTERY, USING N2160 12V DC TO 24 V DC CONVERTER.	2-12
2.2.6	MAIN CABLE PLAN WHEN SUPPLIED FROM AC, USING N2161 AC TO 24V DC POWER SUPPLY. MAIN CABLE PLAN WHEN SUPPLIED BOTH FROM AC AND DC (N2161).	2-13
2.2.7	INSTALLATION WITH REMOTE CONTROL C2140	2-14
2.2.8	INSTALLATION WITH DSC (TELEX) RM2150	2-16
2.2.10	CONNECTIONS TO T2130	2-17
2.2.11	CONNECTIONS TO RE2100	2-18
2.2.12	CONNECTIONS TO AT2110	2-19
2.2.13	CONNECTIONS TO N2161	2-20
2.2.14	CONNECTIONS TO BATTERY CHARGER N2174	2-21
2.3	SYSTEM DESCRIPTION AND TROUBLE SHOOTING	2-23
2.3.3	SYSTEM FUNCTIONAL DESCRIPTION	2-24
2.3.3.1	SP BUS COMMUNICATION TO T2130	2-24
2.3.3.2	AUTOMATIC POWER SETTING	2-26
2.3.3.3	TUNING THE AT2110	2-30
2.3.3.4	TRANSMIT SUPERVISING	2-32
2.3.3.5	CALIBRATION OF THE T2130	2-34

2 INSTALLATION MECHANICAL HF SSB TRANSMITTER T2130

2.1 MOUNTING POSSIBILITIES/DIMENSIONS AND DRILLING PLAN

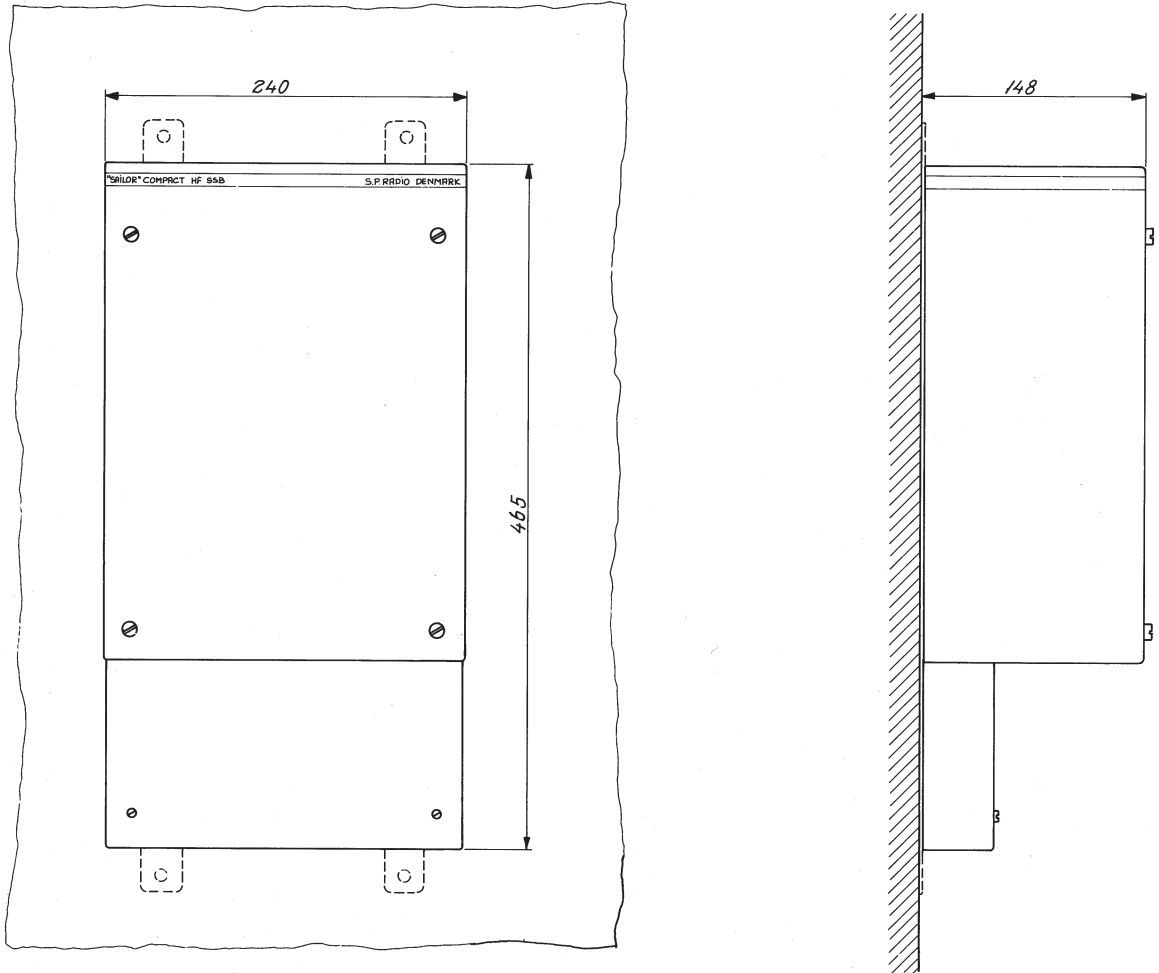

25889B

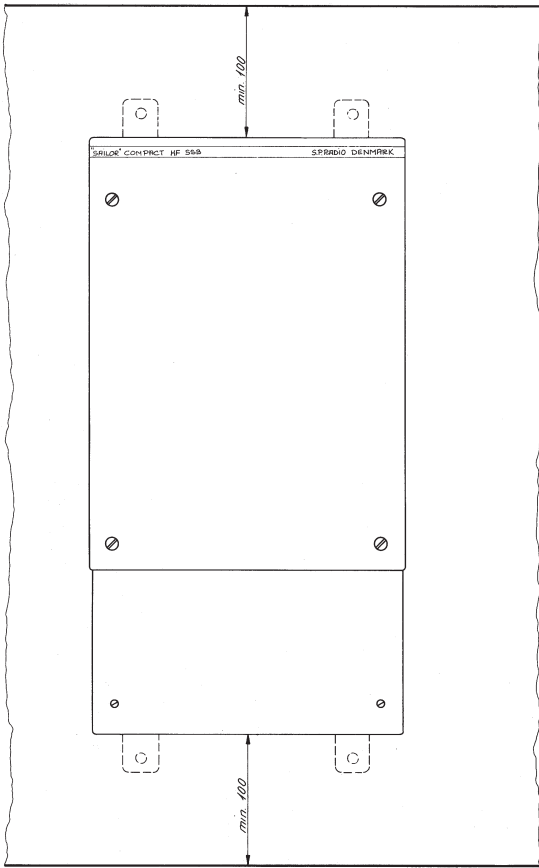

Free space for air circulation.
 Ambient temperature:
 Max. 40°C.
 Weight: T2130: 14 kg

Free space for air circulation
 and cable entry.

25891A

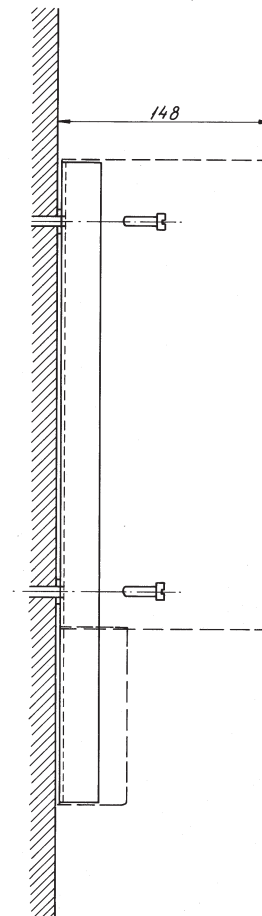
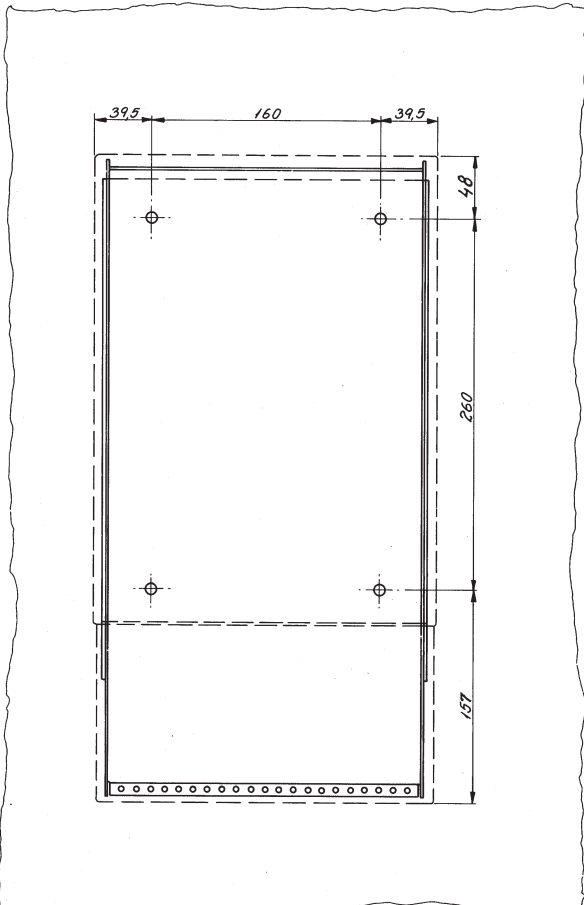

25890A

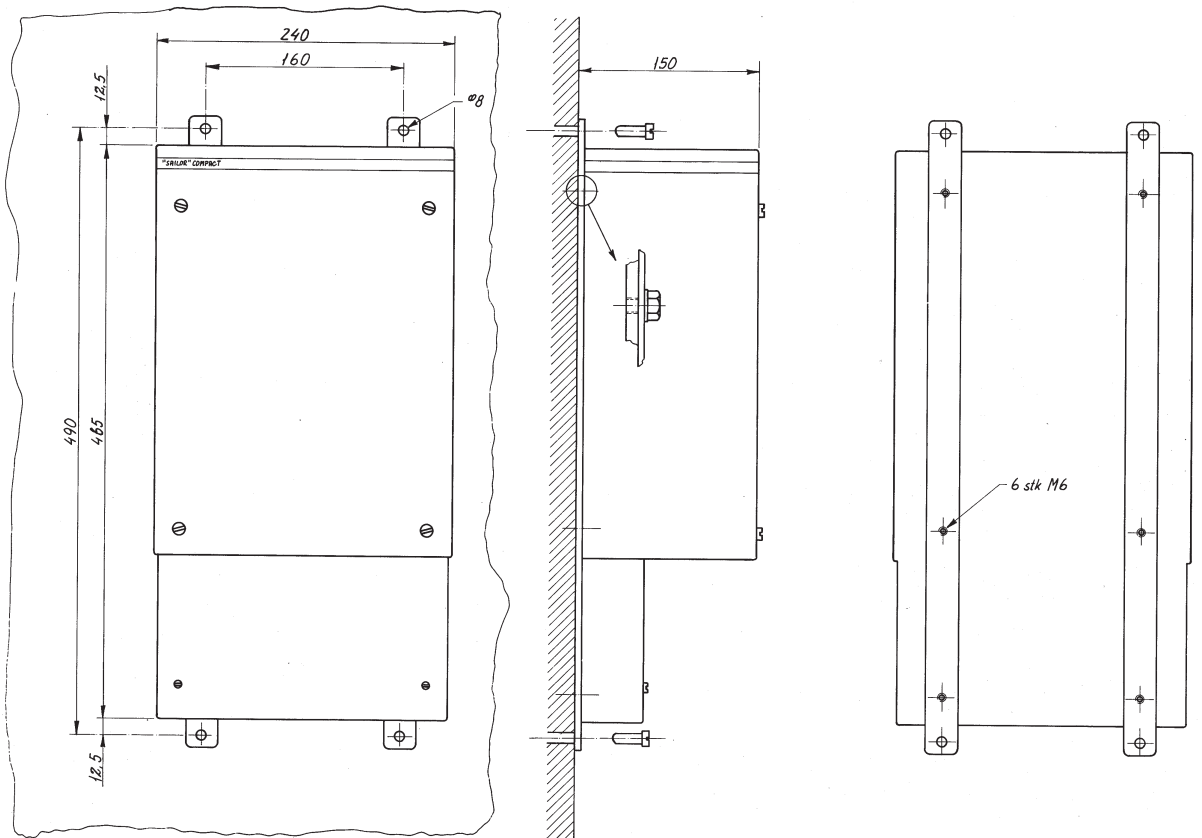

26197A

2.1.1 INSTALLATION HINTS

The HF SSB Transmitter T2130 has to be installed vertically because it is convection cooled.

To ensure free airflow inside the transmitter, at least 100 mm free space is necessary at the top of the cover. At the bottom of the transmitter, 100 mm free space is necessary for cable lead-in.

In order to facilitate the installation, dismantle the turnable inner chassis (see the section 4.0. MECHANICAL DISASSEMBLING). Then install the back plate with the connection board PCB as described in section 2.1. MOUNTING POSSIBILITIES/DIMENSIONS AND DRILLING PLAN.

When all cables have been connected according to the cable plans in question, reinstall the turnable inner chassis and complete the installation by executing the function check (see the section 3.8. FUNCTION CHECK).

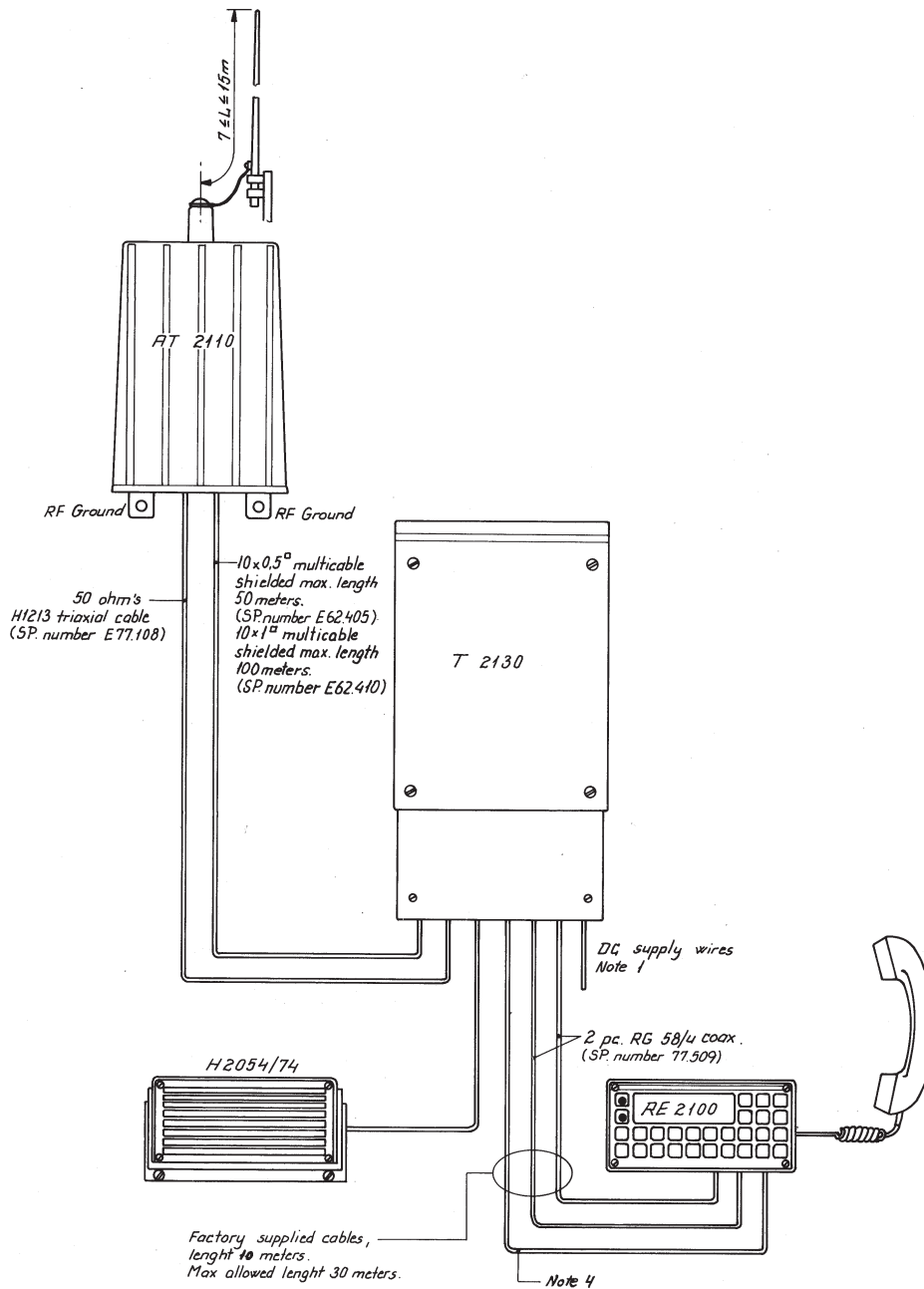

2.2.2 BATTERY REQUIREMENTS FOR GMDSS

6 HOURS REQUIREMENT:

The radio batteries must have sufficient capacity to supply the radio station for 6 hours (3 hours transmit and 3 hours standby).

When the battery is drained in 6 hours, instead of the normal 20 hours, you have add 20% to the capacity given be the manufacture.

The three hours transmit has to be in telex mode ARQ.

Equipment	Mode	Current	Battery capacity
T2130/DSC	transmit	15A	45Ah
T2130/DSC	standby	1A	3Ah
VHF/DSC	transmit	7A	21Ah
VHF/DSC	standby	.33A	1Ah
EMERGENCY LIGHT	on	1A	6Ah
GPS RECEIVER	on	1A	6Ah
TOTAL 6 HOURS			82,0Ah
+20%			98.4Ah

If you chose to make a installation without AC power supply N2161. Then you must have a battery charger large enough to ensure, that you not will drain your batteries during transmission. That gives a charger requirement of 25 amp. The maximum allowable charge current is 10% of the battery capacity. When the charger can give 25 amps the battery capacity must be **250Ah**.

We recommend 250Ah battery capacity.

If you chose to make a installation with AC and DC power supply N2161. Then you must have a battery charger large enough to ensure, that you can charge your batteries, within 10 hours. That gives a charger requirement of 10 amp.

The maximum allowable charge current is 10% of the battery capacity.

We recommend 100Ah battery capacity.

1 HOUR REQUIREMENT:

The radio batteries must have sufficient capacity to supply the radio station for 1 hour (0.5 hours transmit and 0.5 hours standby).

When the battery is drained in 1 hour, instead of the 24 hours, you have add 50% to the capacity given be the manufacture.

The half hour transmit has to be in telex mode ARQ.

Equipment	Mode	Current	Battery capacity
T2130/DSC	transmit	15A	7.5Ah
T2130/DSC	standby	1A	0.5Ah
VHF/DSC	transmit	7A	3.5Ah
VHF/DSC	standby	.33A	.17Ah
EMERGENCY LIGHT	on	1A	1Ah
GPS RECEIVER	on	1A	1Ah
TOTAL 1 HOURS			13.7Ah
+50%			20.6Ah

If you chose to make a installation without AC power supply N2161. Then you must have a battery charger large enough to ensure, that you not will drain your batteries during transmission. That gives a charger requirement of 25 amp.

The maximum allowable charge current is 10% of the battery capacity. When the charger can give 25 amps the battery capacity must be **250Ah**.

We recommend 250Ah battery capacity.

If you chose to make a installation with AC and DC power supply N2161. Then you must have a battery charger large enough to ensure, that you can charge your batteries within 10 hours. That gives a charger requirement of 3 amp.

The maximum allowable charge current is 10% of the battery capacity.

We recommend 60Ah battery capacity.

2.2.3 AERIAL AND RF GROUNDING REQUIREMENTS

AERIAL

Most important for good communication is the aerial. The best efficiency of the aerial will be with the aerial coupler AT2110 mounted outdoors close to the footpoint of the aerial and the aerial placed as high and free as possible. The aerial coupler AT2110 has to be grounded carefully.

AERIAL LENGTH

Max. length 15 metres, min. length 7 metres. Aerial length measured from insulator on AT2110 to the top of the aerial.

If the transmitter has to work mainly on frequencies below 4 MHz a total aerial length of 12-14 metres is recommended.

If the transmitter has to work mainly on frequencies higher than 4 MHz an 8.5 m whip aerial is recommended.

GROUND

AT2110 has to be grounded at the footpoint of the aerial.

If a metal wheel house, weld up a pillar for AT2110 and bolt it to the pillar. This is the best way of getting a good ground for the aerial system.

If a wooden or fibre glass boat, connect all accessible metal parts together and connect them to the aerial coupler with a copper strip (100 x 0.5 m) making the copper strip as short as possible. You can also make an artificial ground under the aerial as shown in example 5.

Example 1. AT2110 mounted on top of a wheel house with a whip aerial.

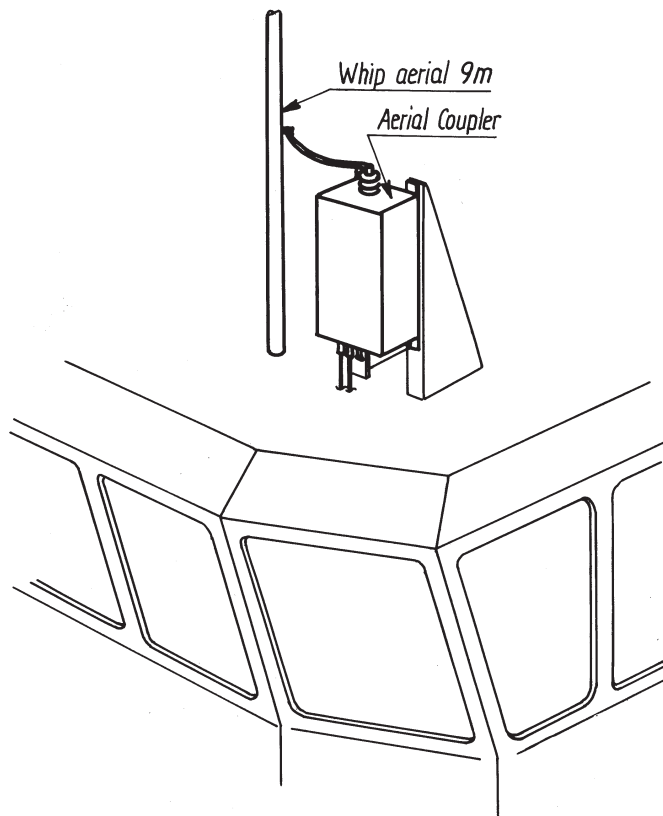

AT2110 has to be grounded through the two lower mounting holes.

Example 2. AT2110 mounted on top of a wheel house with wire aerial.

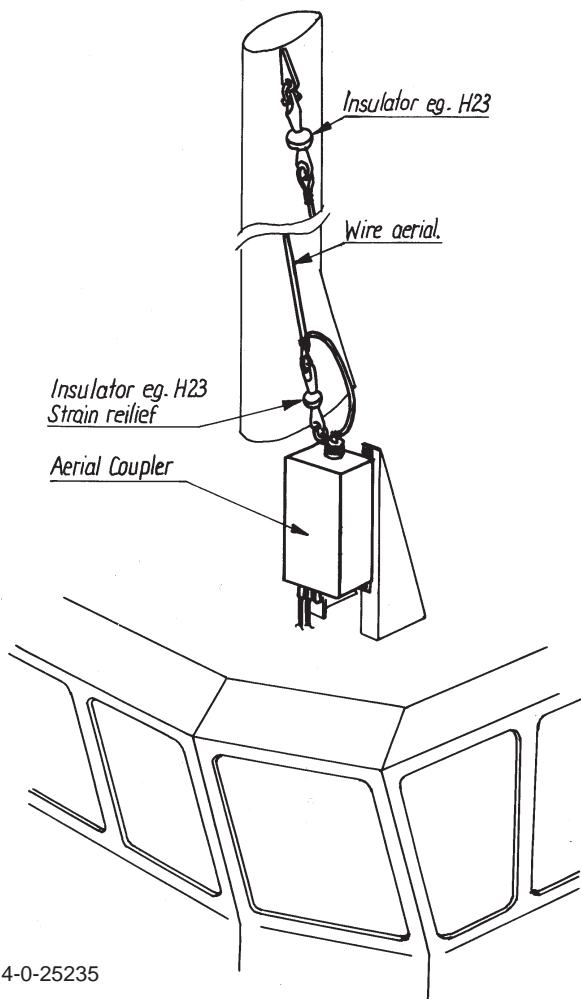

Example 3. AT2110 mounted on top of a mast.

AT2110 has to be grounded to the mast if a metal mast.

If $h > 8$ m then the coax cable works as ground and an acceptable performance will be obtained.

If $h < 8$ m then a copper strip (10 x 0.5 mm) has to be connected from AT2110 to ground. (See chapter GROUND).

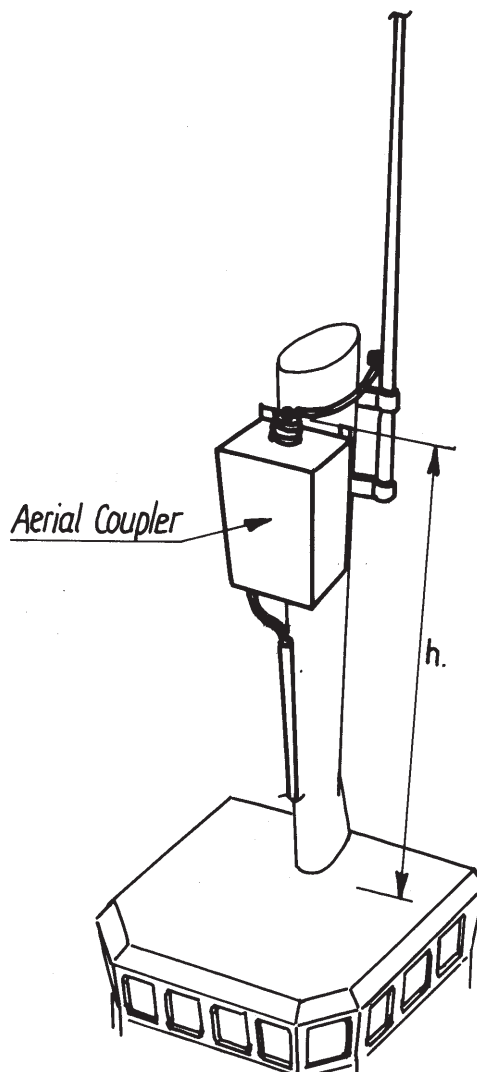

Example 4. AT2110 mounted on a sailing ship.

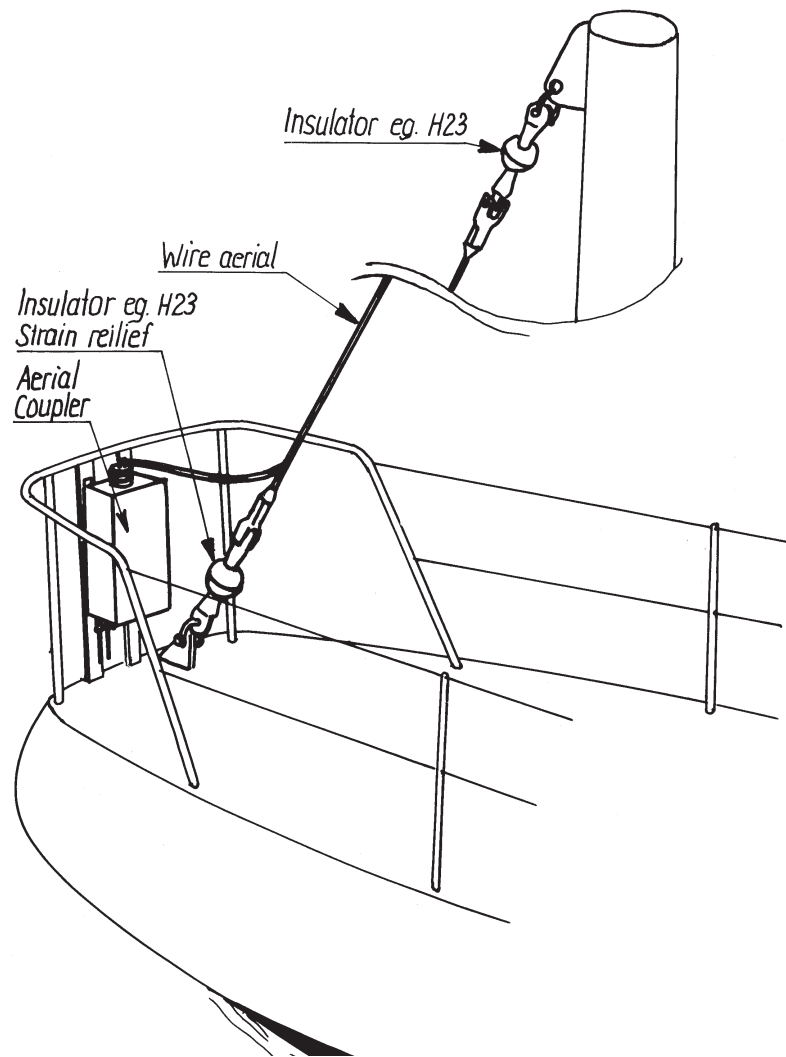

4-0-25237

AT2110 has to be grounded to the metal handrail or other metal parts.

Example 5. AT2110 mounted on top of building.

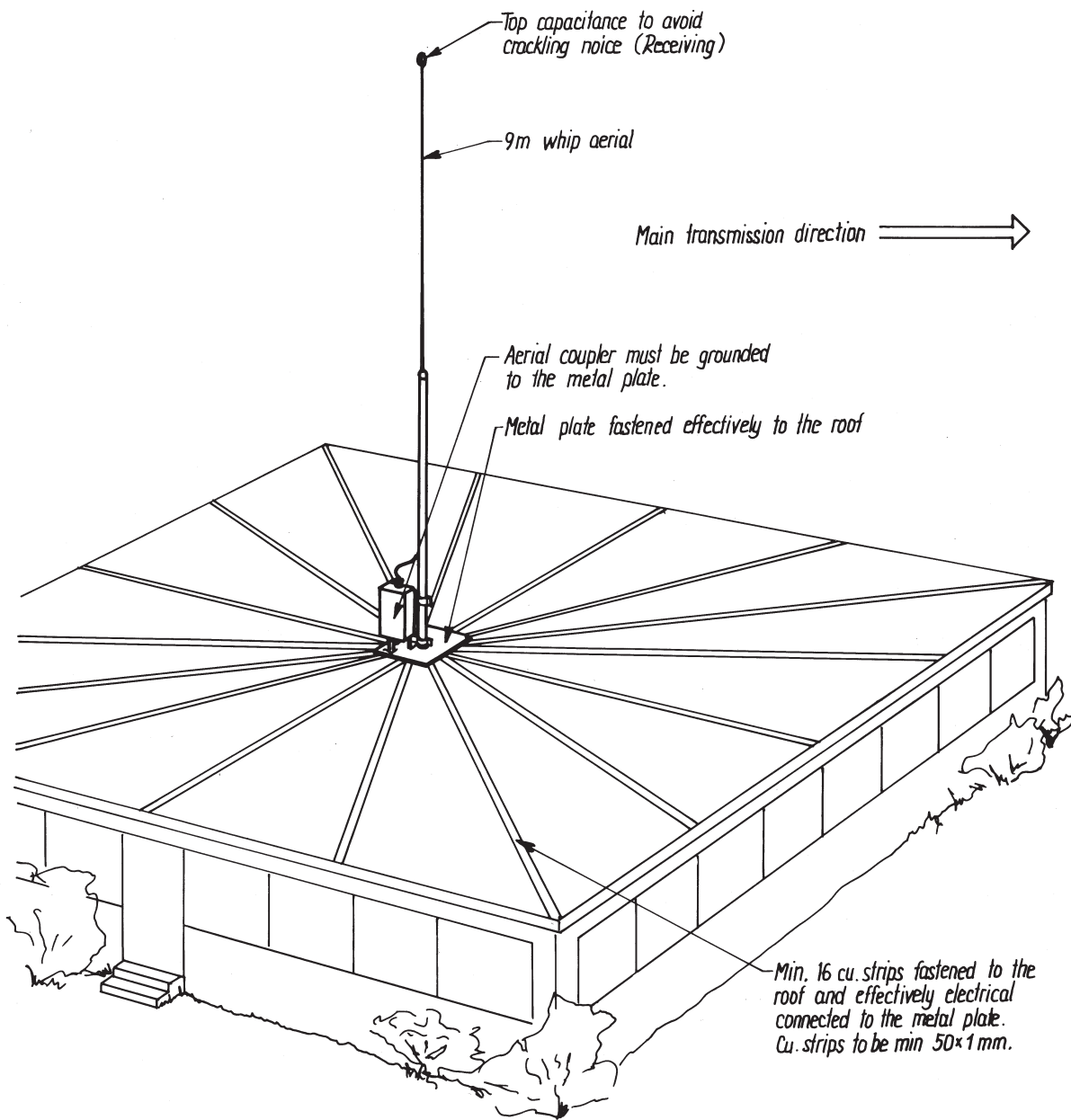

4-0-25239A

2.2.4 MAIN CABLE PLANE WHEN SUPPLIED FROM 24V BATTERY.

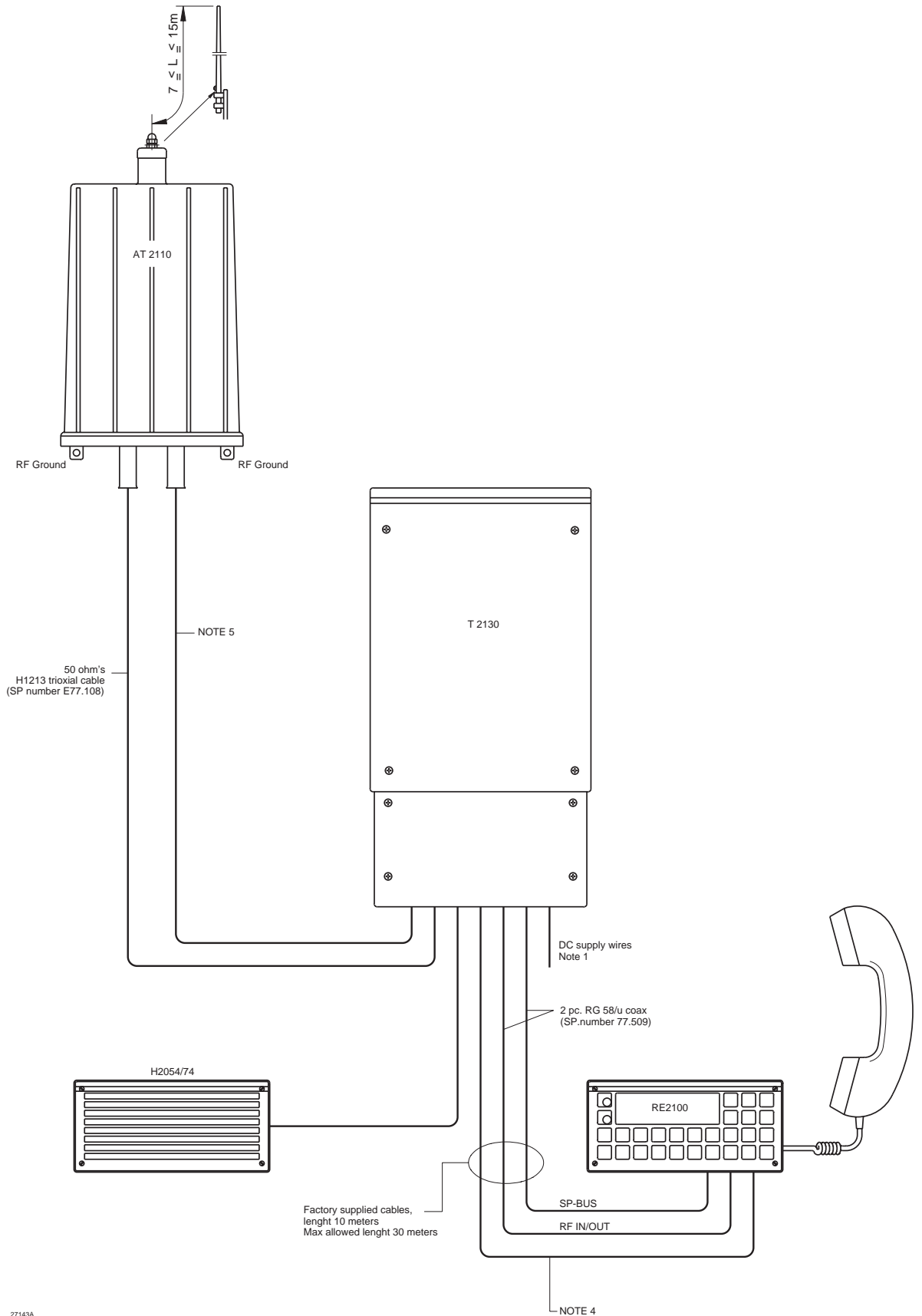

2.2.5 MAIN CABLE PLANE WHEN SUPPLIED FROM 12V DC BATTERY, USING N2160 12V DC TO 24 V DC CONVERTER.

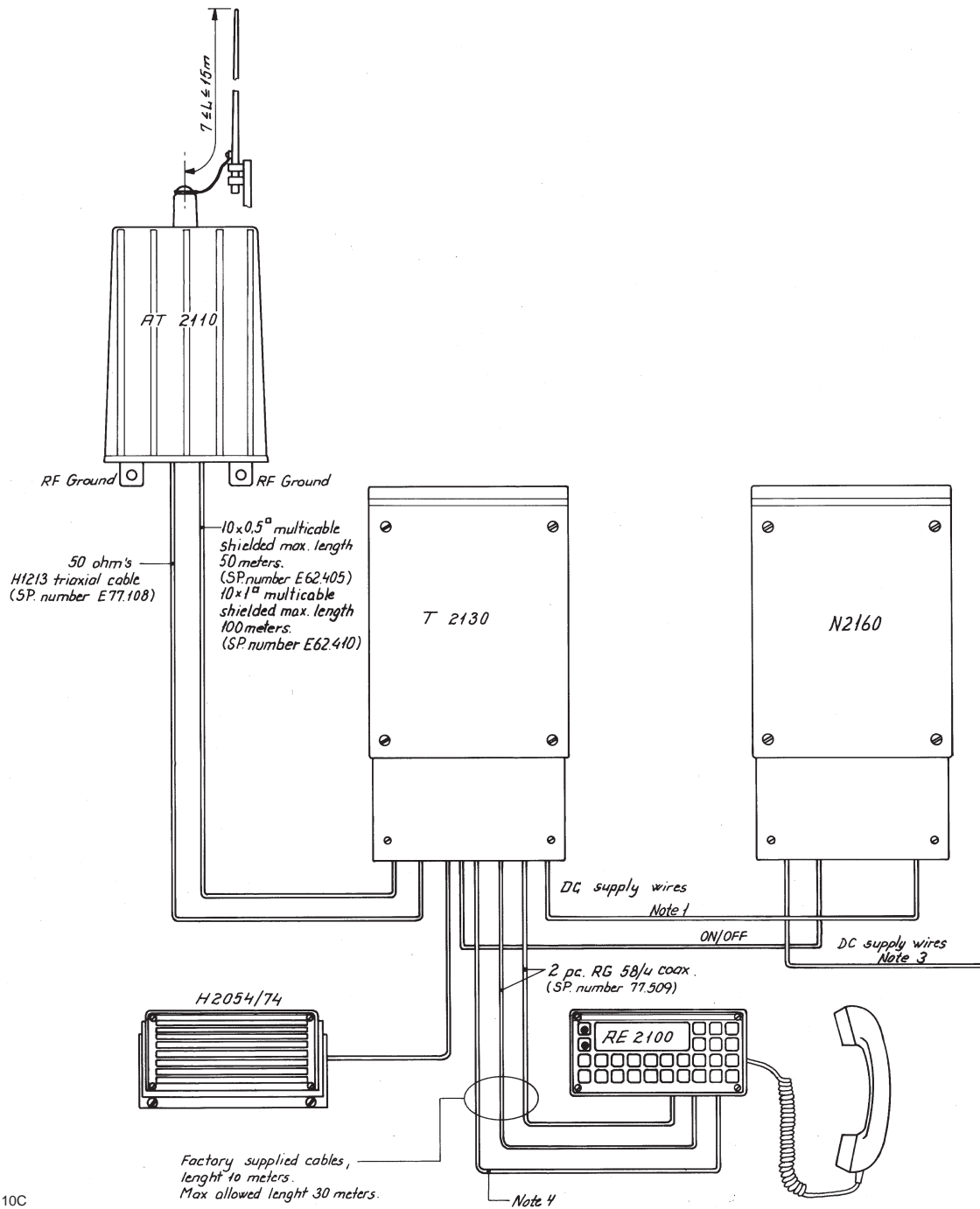

26110C

**2.2.6 MAIN CABLE PLAN WHEN SUPPLIED FROM AC, USING N2161 AC TO 24V DC POWER SUPPLY.
MAIN CABLE PLAN WHEN SUPPLIED BOTH FROM AC AND DC (N2161).**

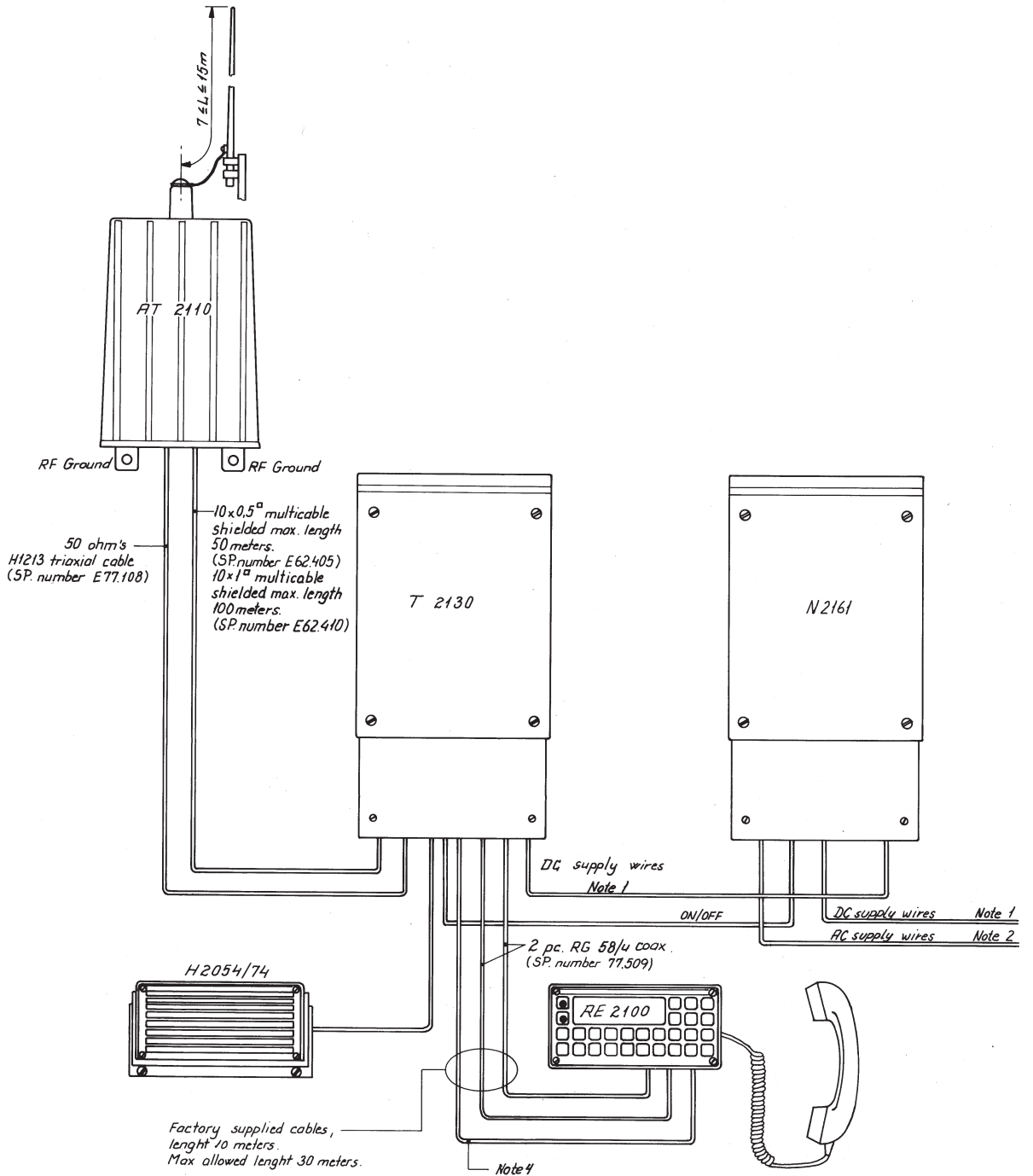

2.2.7 INSTALLATION WITH REMOTE CONTROL C2140

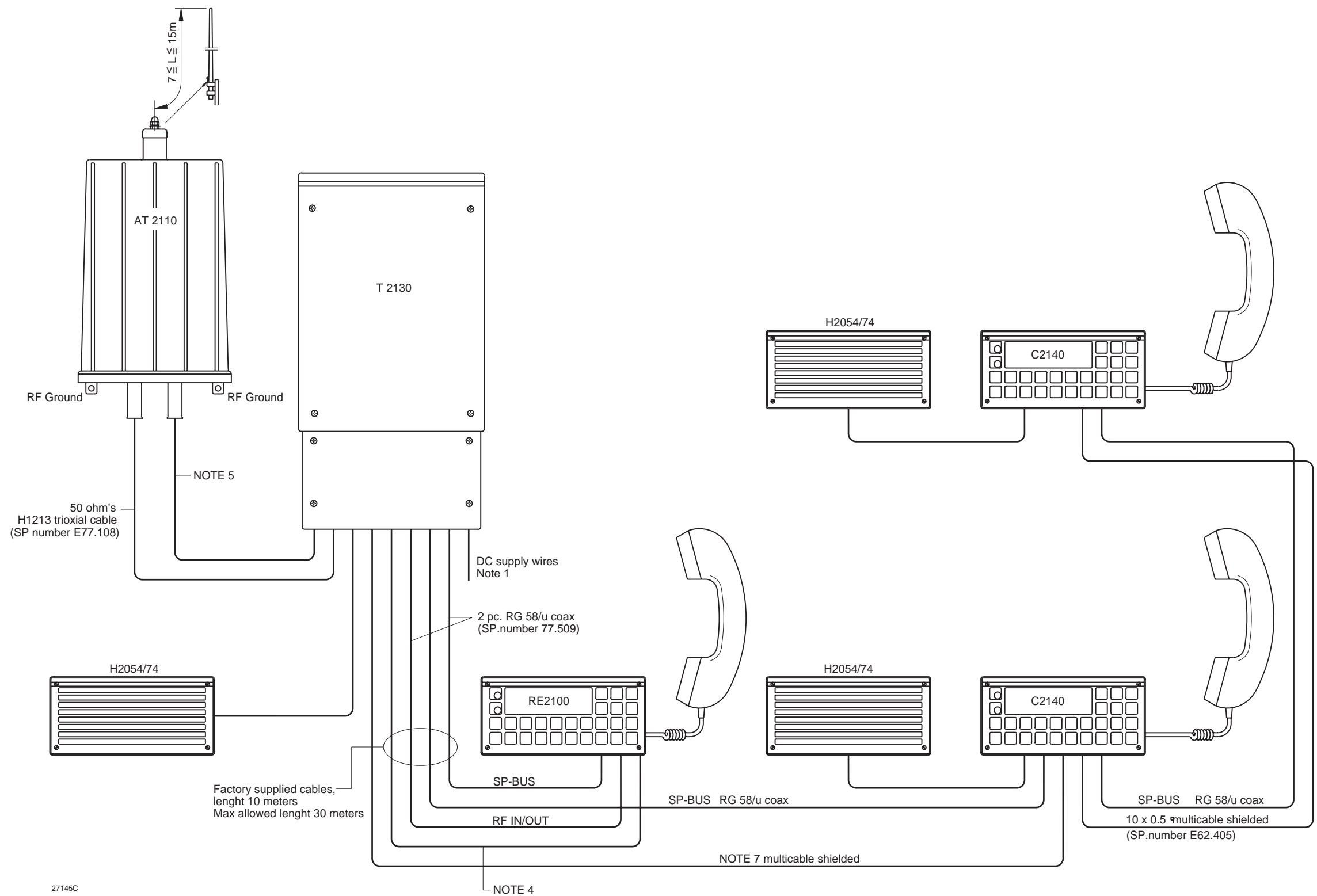

2.2.8 INSTALLATION WITH DSC (TELEX) RM2150

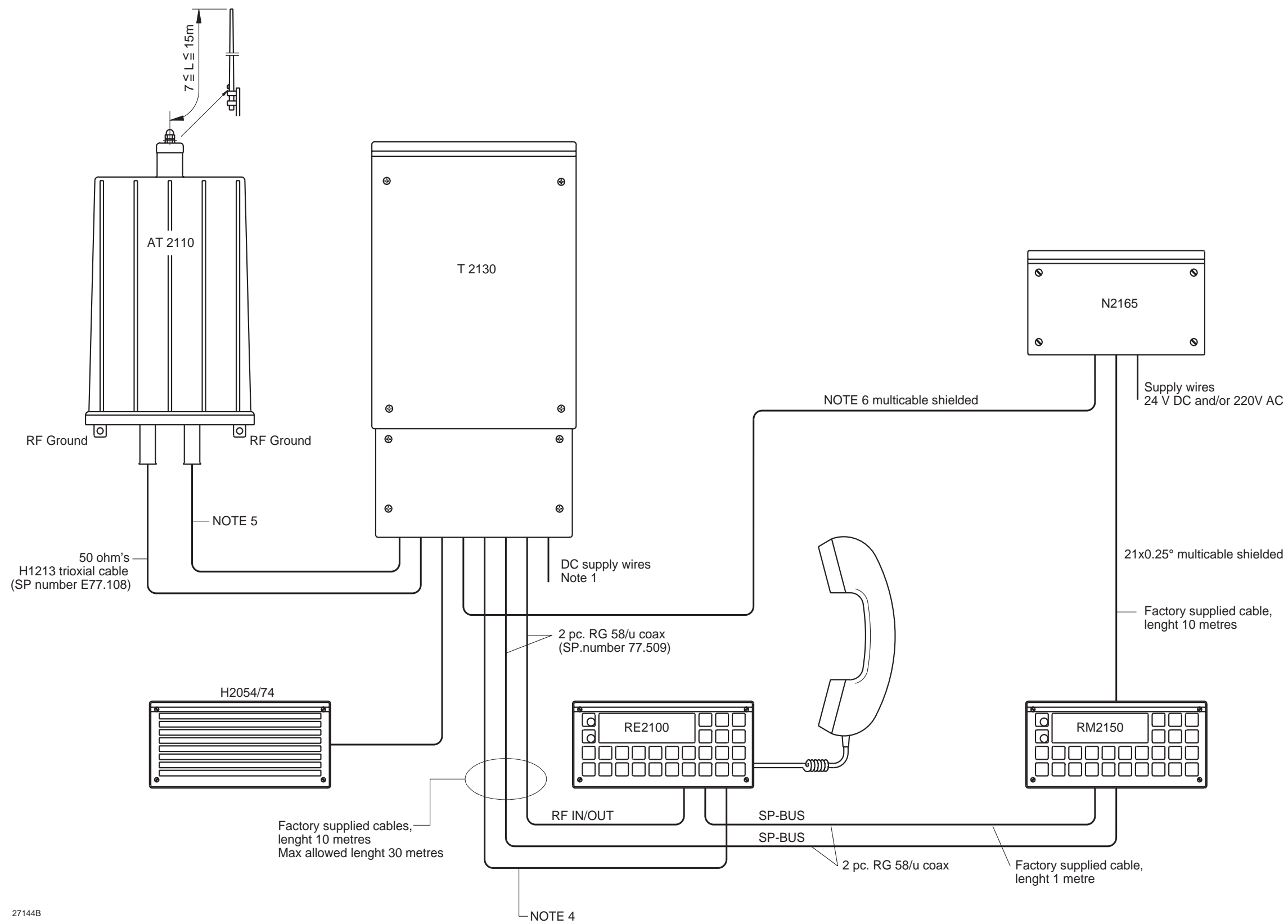

27144B

2.2.10 CONNECTIONS TO T2130

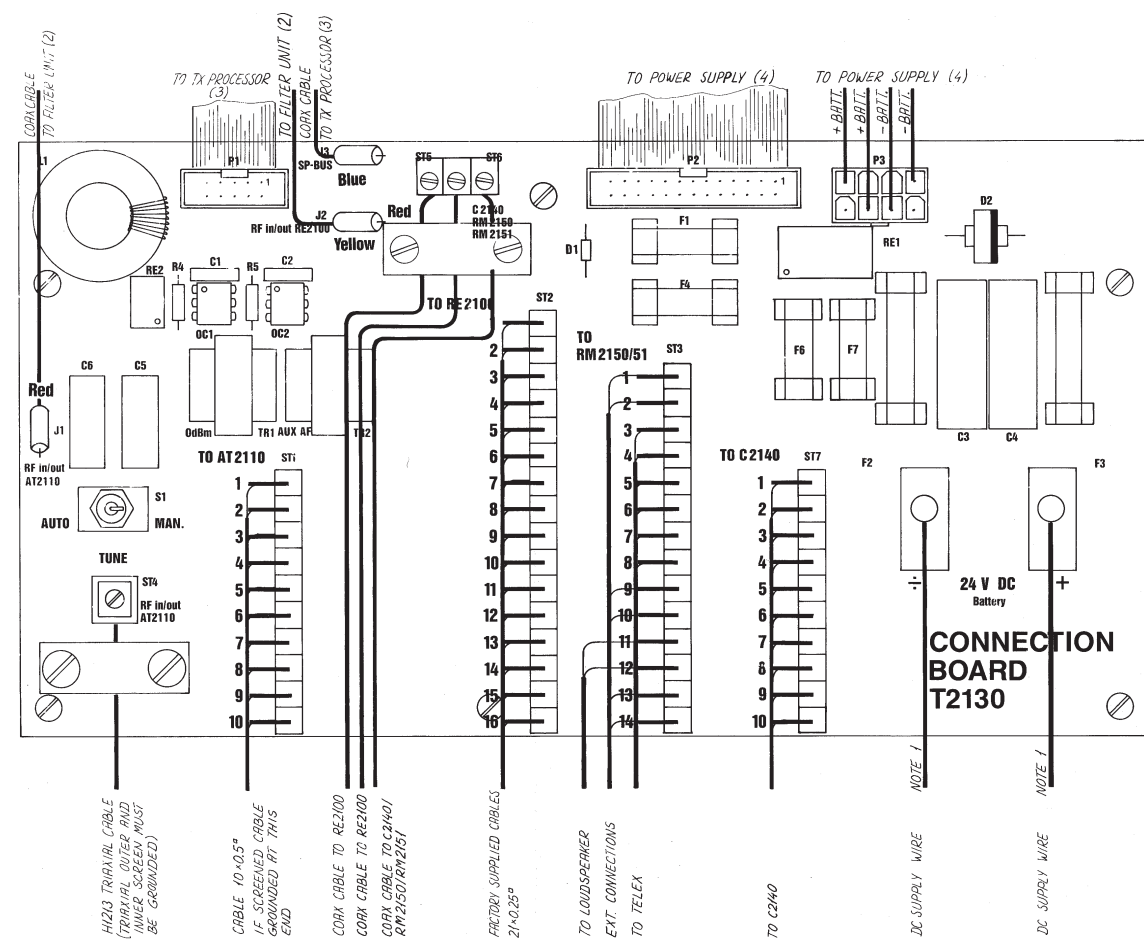

- 1-2 Mute Out**
Relay contact closed when transmitting.
Max. ratings: 30V/2A
- 3-4 TX-key**
Optocoupler:
12V ≤ Vin High ≤ 22V
10mA ≤ Iin High ≤ 20 mA
-1V ≤ Vin Low ≤ 2V
- 5-6 RF On/Off**
Optocoupler:
12V ≤ Vin High ≤ 15V
25 mA ≤ Iin High ≤ 35 mA
-1V ≤ Vin Low ≤ 2V
- 7-8 0 dBm out**
Transformer:
600 ohm, 0 dBm
- 9-10 Aux AF in Tx**
Transformer:
600 ohm, level 0 to 10 dBm
- 11-12 Mute RX In**
Relay Coil:
Max. voltage: 35V, 20°C
Min. voltage: 9V, 20°C
Coil resistance: 2250 ohm ±300 ohm
- 13-14 Loudspeaker**
8 ohm, max. power 10W
- 14-16 Ext. Loudspeaker**
8 ohm, max. power 10W

Note 8

Cable to various equipment.	
RM2150/51	Signal
ST3	
1	MUTE OUT
2	MUTE OUT
3	HT ON-
4	HT ON+
5	TX KEY-
6	TX KEY+
7	AUX AF TO TX
8	AUX AF TO TX
9	MUTE RX IN
10	MUTE RX IN
11	LOUDSPEAKER
12	LOUDSPEAKER
13	EXT LOUDSPEAKER
14	EXT LOUDSPEAKER

Note 1, 2 and 3
Distance / cable dimensions table

Distance in meters	1.3	2	3.2	5	8	10	13	16	24	34	Mains fuse
Copper cable dimensions in mm ²											
Note 1 T2130 DC supply cables 24V DC approx 13A and N2161 DC supply cables 24V DC approx 13A	1.5	2.5	4	6	10	10	16	16	25	35	
Note 2 N2161 AC supply cables 220V AC approx 3A 110V AC approx 6A	1.5	1.5	1.5	1.5	1.5	1.5	1.5	1.5	1.5	1.5	10A 10A
Note 3 N2160 DC supply cables 12V DC approx 50A	4	6	10	16	25	35	50	70	95	120	

Note 4

Cable between T2130 and RE2100			
Cable specifications: Factory supplied, 10 metres 21 x 0,25mm ² multicable with plug. Up to 15 metres cable length use 21 x 0,25mm ² cable. Up to 30 metres cable length use 21 x 0,5mm ² cable.			
T2130	RE2100	Colour	Signal
ST2	J3		
1	1	Black	MUTE RX
2	15	Yellow/brown	Vf/AE-CURRENT
3	11	Violet	+9V
4	12	Grey	+18V
5	13	White	SUPPLY ON/OFF
6	14	Pink/brown	MIC KEY
7	2	Brown	AF TO AMP COMMON
8	16	Brown/green	AF TO AMP
9	17	Brown/grey	0dBm OUT COMMON
10	20	White/green	AUX AF
11	19	White/yellow	RF-GAIN CONTROL
12	18	White/pink	0dBm
13	21	White/blue	TX-KEY
14	10	Blue	-18V
15	25	Red/blue	-BATT.
16	6	Red	SP-BUS INTERRUPT
Chassis	5	Screen	

Note 5

Cable between T2130 and AT2110		
Multicable: Max. Diameter Ø14.5mm Length: Type: 0-50 m 10x0.5mm ² (SP no. E62.405) 50-100m 10x1mm ² (SP no. E62.410)		
T2130	AT2100	Signal
ST1	ST01	
1	1	+21V
2	2	+21V
3	3	AE-CURRENT/180 PULSE
4	4	GND
5	5	CLOCK
6	6	DATA
7	7	MOTOR+
8	8	OVA
9	9	OVA
10	10	OVA

Note 6

Connections to N2165 / RM2150/51				
Cable specification: 6x0.18mm ² max. 30m length.				
T2130		N2165		Signal
ST2	ST3	ST7	ST4	
	5		6	TX-KEY -
4	6			+18V TO TX-KEY +
	7		7	AUX AF TO TX
	8		8	AUX AF TO TX
		7	5	SP-BUS INTERRUPT
		10	3	GND

Note 7

Cable between T2130 and C2140		
For cable specifications: see manual for C2140 (2.3)		
T2130	C2140	Signal
ST7	ST1	
1	1	AUX AF TO TX
2	2	AUX AF TO TX
3	3	0dBm
4	4	0dBm
5	5	GAIN CONTROL
6	6	AE CURRENT/SIGNAL
7	7	SP-BUS INTERRUPT
8	8	-24V DC
9	9	+24V DC
10	10	GND

2.2.11 CONNECTIONS TO RE2100

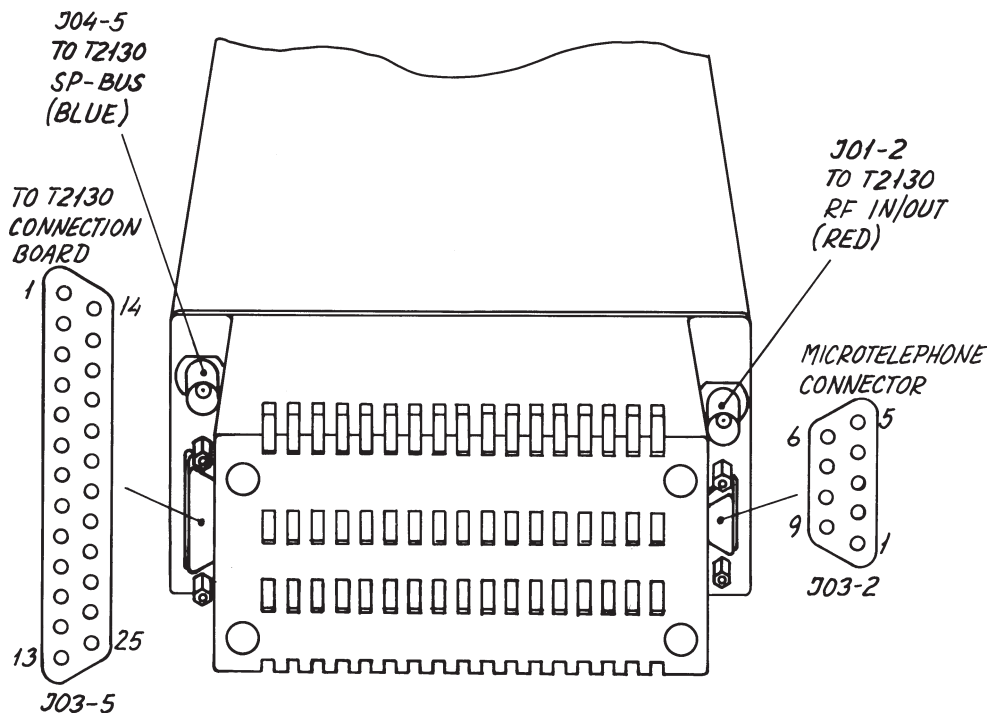

25816

J03-5

Pin no. 1	Mute RX	Black
Pin no. 2	AF to AMP common	Brown
Pin no. 3		
Pin no. 4		
Pin no. 5	GND	Shield
Pin no. 6	SP BUS interrupt	Red
Pin no. 7		Orange
Pin no. 8		Yellow
Pin no. 9	AUX AF to TX common	Green
Pin no. 10	-18V	Blue
Pin no. 11	+9V	Violet
Pin no. 12	+18V	Grey
Pin no. 13	Supply on/off	White
Pin no. 14	Mic key	Brown/pink
Pin no. 15	VF/AE-current	Brown/yellow
Pin no. 16	AF to AMP	Brown/green
Pin no. 17	0 dBm out common	Brown/grey
Pin no. 18	0 dBm out	White/pink
Pin no. 19	Ext. RF control	White/yellow
Pin no. 20	AUX AF to TX	White/green
Pin no. 21	RF on/off	White/blue
Pin no. 22	GND	White/grey
Pin no. 23	+9V	Violet
Pin no. 24	+18V	Grey/orange
Pin no. 25	-battery	Red/blue

J03-2

Pin no. 1	Telephone	Red
Pin no. 2	GND	Yellow
Pin no. 3	Signal GND	White
Pin no. 4	Mic	Blue
Pin no. 5	Mic key	Brown
Pin no. 6	Ext. SQ on/off	
Pin no. 7	Distress	
Pin no. 8	Ser.+	
Pin no. 9	+18V	

2.2.12 CONNECTIONS TO AT2110

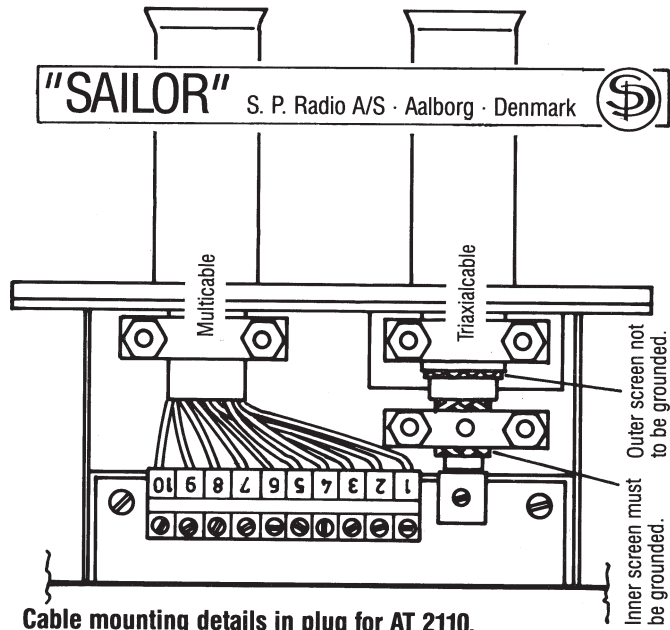

Cable mounting details in plug for AT 2110.

Cable installation:

When removing the 4 screws in the AT2110 plug, the plug can be lowered 60 mm to allow cable installation.

OBS. The plug cannot be removed from the AT2110 during installation

The numbers on the supply terminal block at Connection and Interface PCB in AT2110 correspond with the numbers on the supply terminal block at the Connection Board PCB in T2130.

9-3-26101

WIRE STRIPPING FOR TRIAXIALCABLE H1213

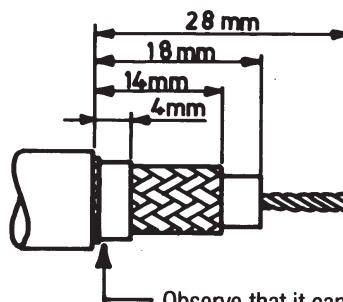

Observe that it can be necessary to isolate outer screen with insulating tape to ensure that it is not grounded.

MULTICABLE:	Max. diameter \varnothing 14.5mm
Length:	Type:
0 - 50m	10 x 0.5 mm ²
50 -100m	10 x 1 mm ²

2.2.13 CONNECTIONS TO N2161

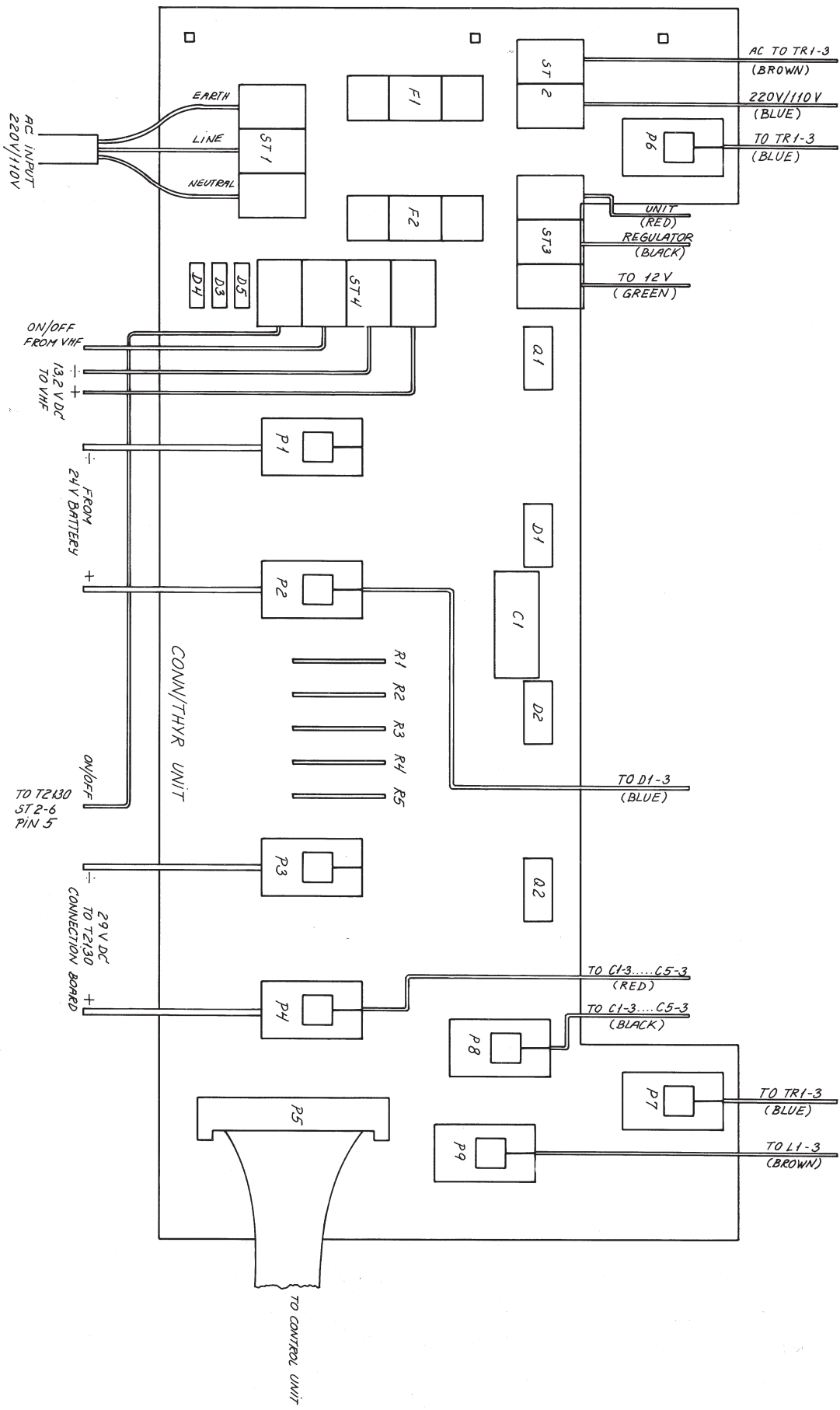

2.2.14 CONNECTIONS TO BATTERY CHARGER N2174

CABLE 9

MAINS TO N2171:

220V MAINS:Current: approx 6 Amp.
 Mains fuse min. 10 Amp.
 3 x 1.5 mm² max. length 12 metres
 110V MAINS:Current: approx 12 Amp.
 Mains fuse min. 16 Amp.
 3 x 2.5 mm² max. length 10 metres

CONNECTION BOARD (5)	SIGNAL
ST1 and ST2	
1	GND
2	LIVE
3	NEUTRAL

CABLE 12

BATTERY TO T2131:

When N2170 is in a separate cabinet.
 Use following cable: 2.5 mm² max. length 10 metres.

When N2170 is in the same cabinet as T2131.
 Use cable as shown in the table below:
 Current consumption: 50 Amp.

LENGTH IN METRES	2	3.2	5	8	10	13	16	24	34
CABLE DIMENSION	6	10	16	25	35	50	70	95	120

CABLE 18

MAINS TO N2174:

220V MAINS:Current: approx 8 Amp.
 Mains fuses 16 Amp.
 3 x 1.5 mm² max. length 12 metres
 110V MAINS:Current: approx 16 Amp.
 Mains fuses 25 Amp.
 3 x 2.5 mm² max. length 10 metres

N2174	SIGNAL
ST2	
1	GND
2	LINE
3	NEUTRAL

CABLE 19

N2174 TO H2180:

Multicable: 6 x 0.75 mm² max. length 15 metres
 Multicable: 6 x 1.5 mm² max. length 30 metres

N2174	H2180	SIGNAL
ST7		
1	1	- SHUNT
2	2	+ SHUNT
3	3	-VS
4	4	MAN
5	5	26V
6	6	AUTO

CABLE 20

N2174 TO H2182/H2183 (SHUNT):

4 x 1.0 mm² max. length 10 metres
 4 x 2.5 mm² max. length 25 metres

N2174	SIGNAL
ST6 ST4 ST10	
1 1 1	- VS
2 2 2	+ VS
3 3 3	SHUNT
4 4 4	SHUNT

CABLE 21

N2174 TO H2182/ (BATTERY):

+ BATT. and - BATT. cable dimensions in mm²
 Current 30A

LENGTH IN METRES	8	13	22	30	40
CABLE DIMENSION	10	16	25	35	50

CABLE 22

H2182 to battery:

+ BATT. and - BATT. Cable dimensions in mm²
 Current approx. 70A

LENGTH IN METRES	2.5	4	6	8	12
CABLE DIMENSION	16	25	35	50	70

CABLE 26

N2174 TO H2182/H2183

(Temperature sensor):

Multicable: 2 x 0.5 mm² max. length 50 metres

N2174	SIGNAL
ST4 ST2 ST8	
1 1 1	-TS
2 2 2	+TS

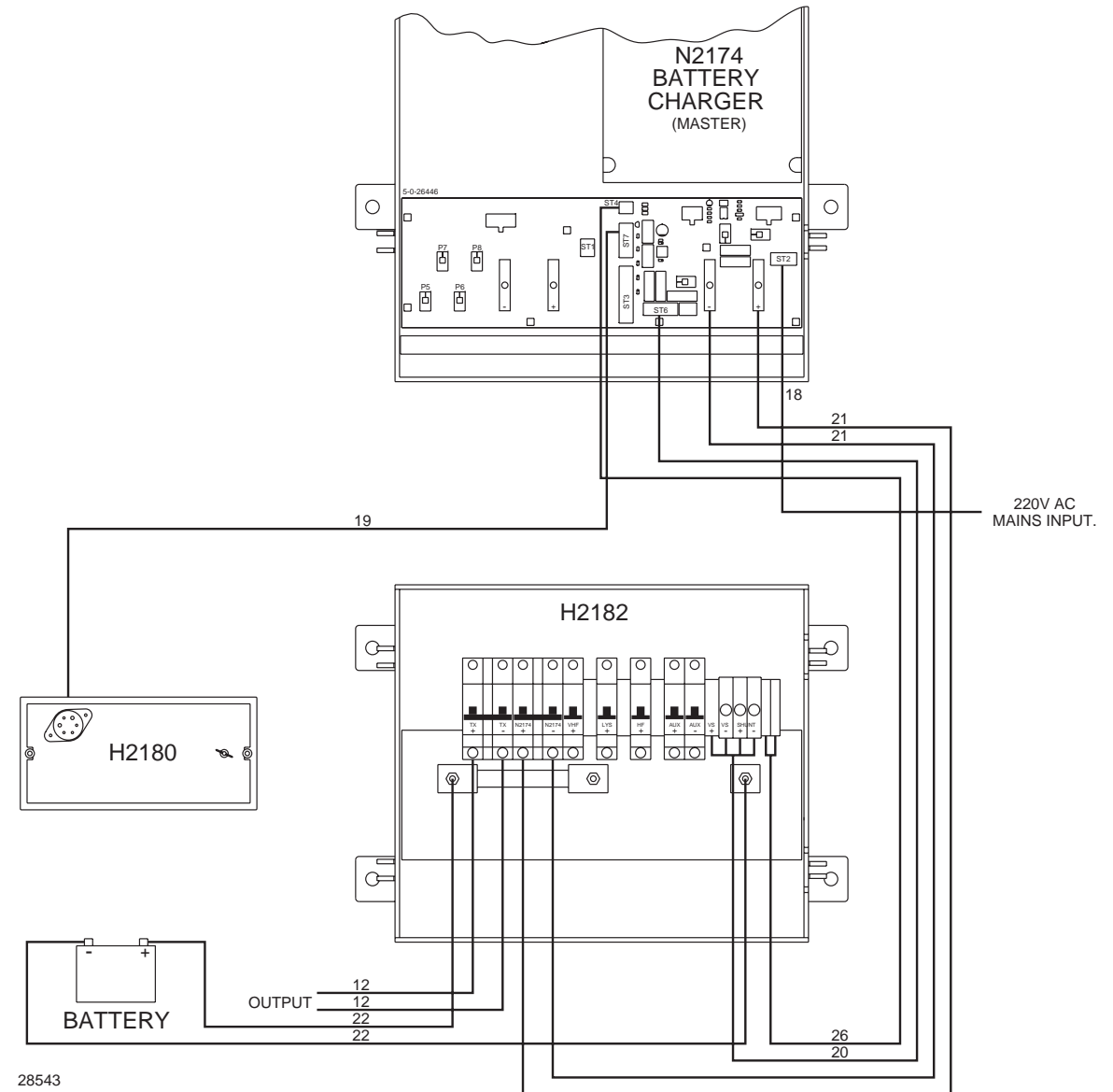

28543

CONNECTIONS TO BATTERY CHARGER N2174

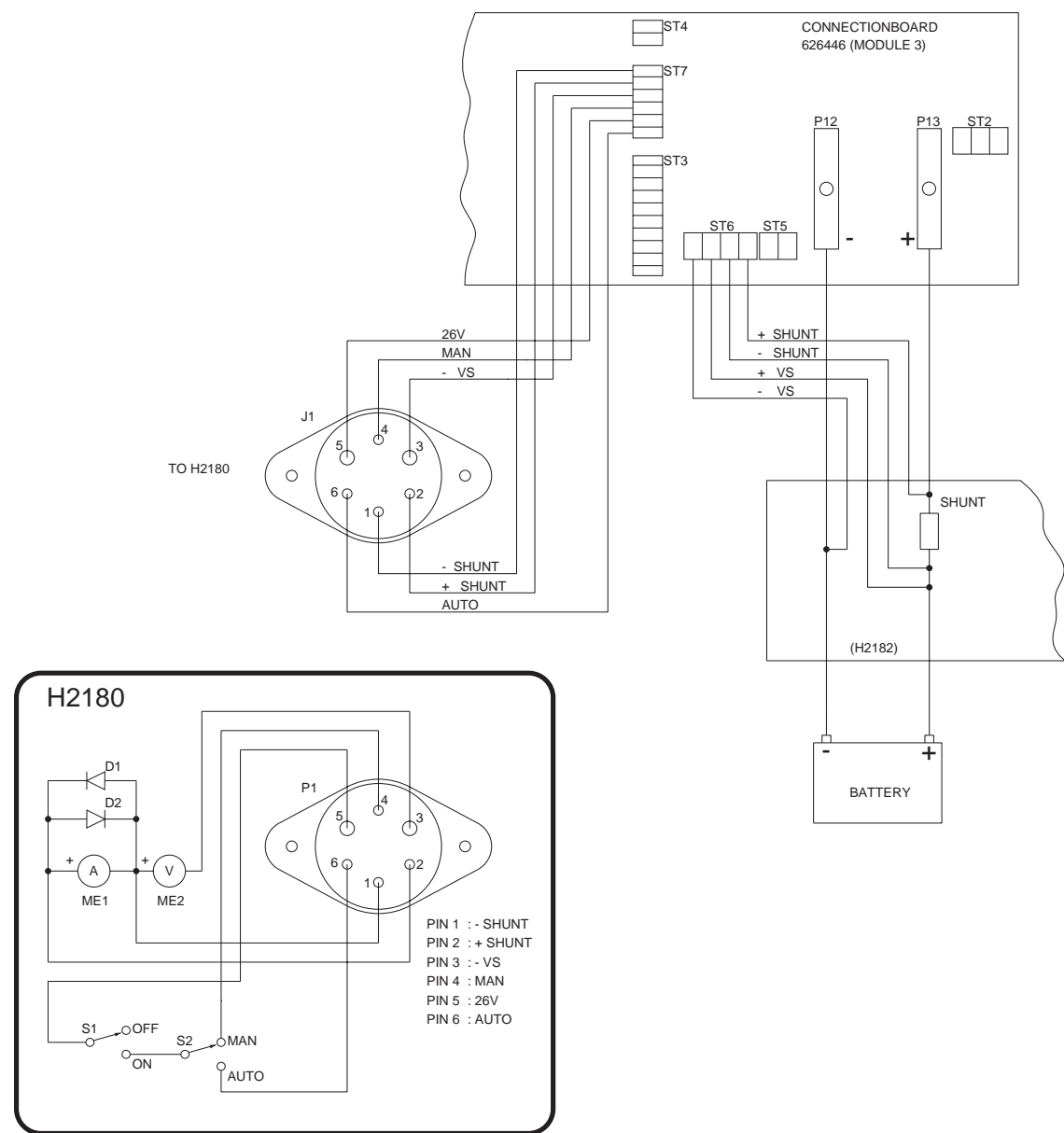

28223

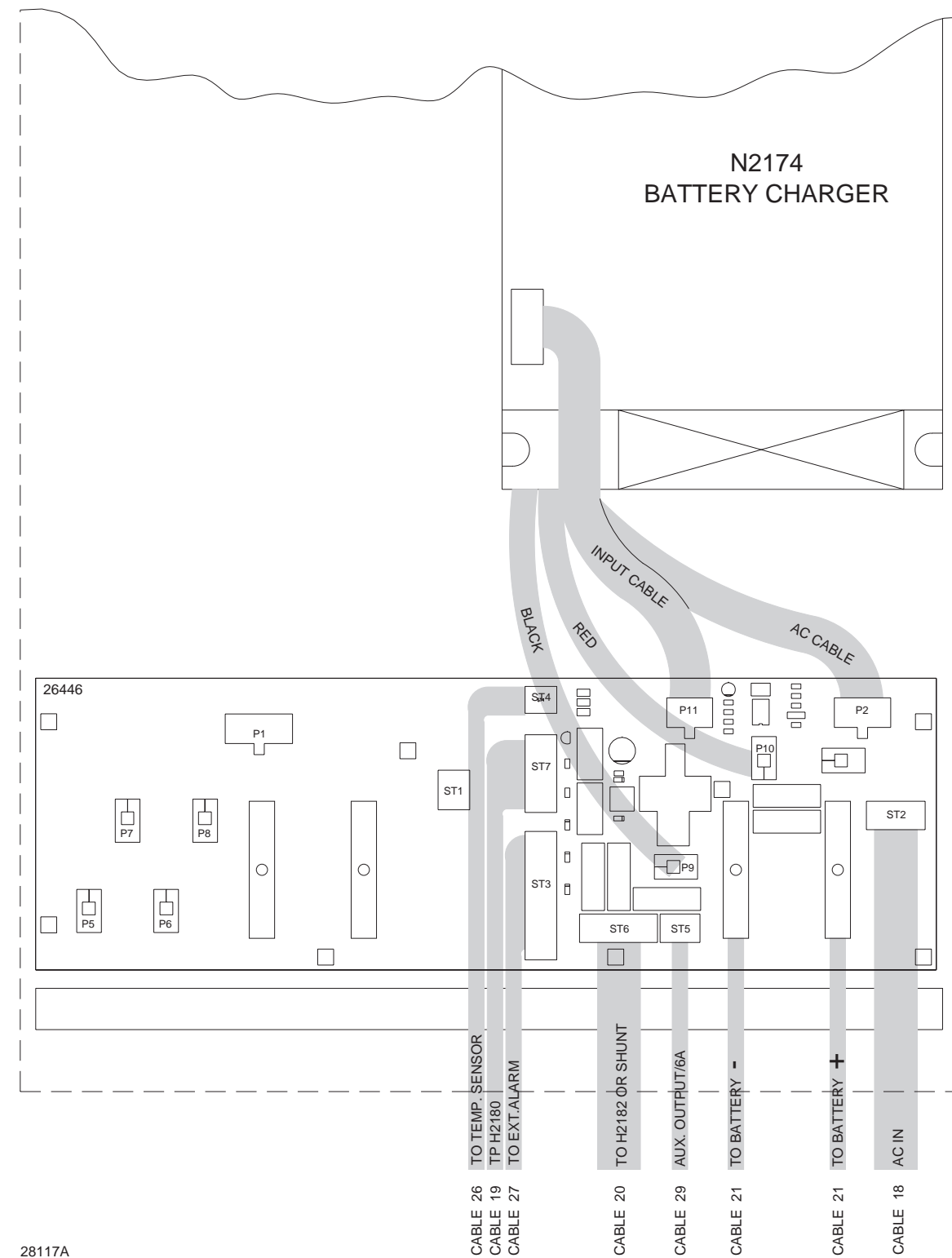

28117A

2.3 SYSTEM DESCRIPTION AND TROUBLE SHOOTING

ERROR MESSAGES

The error messages are displayed in the upper part of the display in the RE2100.

Table 1 indicates the possibly faulty units. An asterisk in parenthesis indicates the alternative unit where the error also may be found.

Table 1

ERROR	RE2100	T2130	AT2110
70		*	*
71	*	*	
72	*	(*)	
73		(*)	*
74		*	
75		(*)	*
76		*	
77		*	
78		*	

The error messages numbered from 70 to 78 are generated by the TX-processor and mainly related to the T2130 and the AT2110. For the detailed error description please refer to the section **3.4.1. REPLACEMENT OF COMPONENT.**

2.3.3 SYSTEM FUNCTIONAL DESCRIPTION

This section describes mainly the overall functions of the software in the T2130.

The main functions are described in sections, where section **2.3.3.1. SP-BUS COMMUNICATION TO 2130** is a common section to be read in conjunction with the others.

In order to have the full understanding of the mode of operation of the T2130, section **2.3.3. SYSTEM FUNCTIONAL DESCRIPTION** has to be read together with section **5. CIRCUIT DESCRIPTION**.

This section describes the following functions:

- **2.3.3.1 SP-BUS COMMUNICATION TO T2130**
- **2.3.3.2 AUTOMATIC POWER SETTING**
- **2.3.3.3 TUNING THE AT2110**
- **2.3.3.4 TRANSMIT SUPERVISING**
- **2.3.3.5 CALIBRATION OF THE T2130**

2.3.3.1 SP BUS COMMUNICATION TO T2130

The SP-Bus is a time-multiplexed serial data bus. The RE2100 is the master and the T2130 is one of several slaves. The T2130 is assigned a given slave address. RE2100 initiates and controls all communication to the T2130. This means that all activities performed in T2130 is controlled by the RE2100.

The T2130 may receive a number of commands according to the expected action in the T2130. When the T2130 has received a message it must replay immediately. The T2130 has four different options to answer the RE2100:

- A: The received command is understood and is executed.
- B: The received command is understood and T2130 is busy executing the command.
- C: The received command is understood and is executed. The T2130 has information for the RE2100.
- D: A communication error is detected. The command is not executed. The error can be a parity error or a message length error.

The answer options A, B, and C may be followed by information related to the specific command. If the T2130 does not answer the RE2100, the RE2100 is repeating the command a number of times. If the T2130 does still not answer, an error (Error 20) will occur in the display in the RE2100.

COMMANDS AND ANSWERS.

In the following the commands to the T2130 and the answers from T2130 are described.

SYNCRONIZE/STATUS AND ERROR CODE

This command/answer is used in two situations:

- When the power has been switched on at the RE2100, the RE2100 detects the existence of possible slaves.
- When the T2130 has detected an error the T2130 has answered the previous message with the answer option (C). This results in a synchronized message from the RE2100.

RECEIVER FREQUENCY

Whenever the received frequency has been changed at the RE2100, the frequency is sent to the T2130. The T2130 ensures that a transformer is switched in at receiver frequencies below 4000 kHz and switched out at frequencies above 4000 kHz.

KEY

This command is sent continuously to the T2130 when the handset key is activated at the RE2100. The first time it is sent the command is followed by the actual transmitter frequency and the selected mode (telex etc.) at the RE2100. The answer is option (A). The following commands are sent without associated data. There are two different answers depending on the state of the T2130. In both states the T2130 has the full control of the step attenuator placed in the Exciter Unit (4) in the RE2100.

- State one. Indicates that the T2130 and the AT2110 are NOT ready to transmit. The answers consist of the answer option (B) associated with an absolute step. The duration of this state is given by the duration of the automatic power setting and the tuning of the AT2110.
- State two. The T2130 and the AT2110 are ready to transmit. The answers consist of the answer option (A) associated with an absolute step. This state continues until the key is released and the 'Stop' command is sent from the RE2100.

TUNE

This command is a subset of the 'Key' command. Only state one is performed followed by the 'Stop' command. The command is only sent from the RE2100 when the 'TX' and 'Tune' keys are activated.

DUMMY LOAD KEY

This command is equal to the 'Key' command except for the RF output power. The RF output power is delivered to the AT2110 built-in dummy load instead of the connected aerial.

DUMMY LOAD TUNE

This command is equal to the 'Tune' command except for the RF output power. The RF output power is delivered to the AT2110 built-in dummy load instead of the connected aerial.

STOP TUNE/KEY

This command always terminates the above mentioned 4 variants of the 'Tune' and 'Key' commands. The answer is option (A). The command is sent from the RE2100 at one of the following events:

- When the handset key is released after a transmit period.
- When the T2130 is ready to transmit after the 'TX' and 'Tune' keys have been activated.
- When the 'Enter/Stop' key is pressed while the Automatic Power setting or the tuning of the AT2110 takes place.

OPEN AERIAL

This command sets the relays in the AT2110 so that the aerial is disconnected from the HF SSB radiotelephone.

SERVICE

This command is always given associated with a service subcommand. There are several service subcommands, each corresponding to a given Service Programme. The answer consists of option (A) or (B) followed by 5 ASCII characters which are displayed in the lower part of the display in the RE2100.

2.3.3.2 AUTOMATIC POWER SETTING

MOTIVE FOR THE AUTOMATIC POWER SETTING

The automatic setting of the power level is done to ensure the maximum RF-level out of the transmitter T2130, regardless of

- variations in the RF-level out of the RE2100 exciter,
- RF-loss due to long cables between RE2100 and T2130,
- variations in the gain in the Power Amplifier from one to another,
- variations in the gain in the Power Amplifier due to the frequency,
- variations in the loss in the Output Filter module from one to another,
- variations in the loss in the Output Filter module due to the frequency,
- battery voltage supplying the Power Amplifier.
(variations in the DC loss in the Power Supply).

PRINCIPLES FOR THE AUTOMATIC POWER SETTING

The RF-level out of the RE2100 exciter is increased in steps until a predetermined maximum allowable Vforward level out of the Output Filter (2) is reached.

EVENTS FOR STARTING THE AUTOMATIC POWER SETTING

The automatic power setting is done because of one of the following events:

- The TX-frequency is changed and the key on the handset has been activated.
- The TX-Tune key on the keyboard is pushed.
- The time elapsed since latest automatic power setting is more than approx. 4 minutes.

NECESSARY SIGNALS AND PARAMETERS

- Vforward.
The RF-level is measured by SWR-detector circuitry on the Output Filter (2) and is mentioned as 'Vforward'. Vforward is measured by the TX-processor (3) by means of an analog to digital converter.

- Vforward maximum.
The predetermined maximum allowable Vforward level is composed of a number of parameters. This composition of the maximum allowable Vforward is described in a section below. In the following it is assumed that the maximum allowable Vforward has already been calculated.
The predetermined maximum allowable Vforward level will in the following sections be mentioned as Vf_max (Vforward maximum).
- RF level control.
A digitally controlled step attenuator with 64 steps, each step is approx. 0.3 dB, is placed in the Exciter Unit (4) in the RE2100. During the automatic power setting the TX-processor (3) in the T2130 has the full control of the step attenuator via the SP-Bus and the Processor Module (5) in the RE2100.

FUNCTIONAL DESCRIPTION OF THE AUTOMATIC POWER SETTING

When the automatic power setting is about to start the step attenuator in the Exciter Unit (4) is preset to step 43 by the answer to the first 'Tune' command.

The automatic power setting may now take place in 2 or 3 states, depending on the initial measured Vforward (step 31) related to the Vf_max.

- State 1 is always run as the first state.
- State 2 is run when the RF-level has to be increased one or several steps.
- State 3 is always run as the last state in the automatic power setting.

STATE 1

The Vforward level (step 43) is measured by the TX-processor and compared to 4 different levels:

- A minimum level.
If Vforward is lower, then an error is generated. The Vforward level is too low.
- Vf_max - 0.6 dB.
If Vforward is lower, then a number of steps is calculated for increasing the RF-level out of the Exciter. The calculation is described below. The automatic power setting continues at state 2.
- Vf_max.
If Vforward is lower or equal to, then the step is increased with one, The automatic power setting continues at state 2.
- Vf_max + 0.3 dB.
If Vforward is lower, then the automatic power setting continues at state 3. Else an error is generated. The Vforward level is too high.

STEP CALCULATION

In order to reduce the time used for the automatic power setting the RFlevel is increased a number of steps initially. The number of steps 'n' is calculated in the following way:

$$Vf_max = 10 ((A / 20)) * n$$

Vforward

Where A is the resolution of the step attenuator in dB. Theoretically A should be = 0.3 dB/step. However, there is some compression in the amplifiers, etc. involved. Iterations have shown that A = 0.43 dB/step is suitable in order to reach the correct power level in an acceptable time without overshooting.

STATE 2

In this state the RF-level is increased one step at a time and compared to 2 different levels:

- Vf_max.
If Vforward is higher then the automatic power setting continues at state 3.
- The previous measured Vforward + 0.12 dB.
If Vforward is lower then the automatic power setting continues at state 3.
Else state 2 is repeated.
This specification compared to the previous Vforward + 0.12 dB is performed to ensure that the increasing of the Vforward is stopped if there has been an increase less than 0.12 dB. This may occur when the Power Amplifier (1) has begun compressing the signal. The compressing of the signal gives distortion and reduces the intermodulation.

STATE 3

This state is run when the Vforward was measured to be one step too high. RF-level is reduced one step because the previous level was too high.

Depending on which event has started the automatic power setting the RFlevel is reduced further. If an AT2110 is in the system, (jumper 5 is not inserted) Vforward is further reduced 20 steps (approx. 6 dB) in order to protect the Power Amplifier (1) while tuning the AT2110.

CALCULATING VFORWARD MAXIMUM

Vf_max is compounded of 4 parameters:

- A value (Vf_max1) calculated from the Vforward - Vbattery equation (the graph in fig. 1).
- An addition (Vf_max2) as a result of the calibration. The calibration procedure is described in section **2.3.3.5 CALIBRATION OF THE T2130**
- An addition (Vf_max3) related to the frequency.
- A reduction (Vf_max4) because of reduced power.

Vf_max is found in the following way:

- Vfmax5 = Vf_max1 + Vf_max2 + Vf_max3
- Vf_max = the lowest of Vf_max4 and Vf_max5

In the following the parameters are described separately.

Vf_max1 (VFORWARD - VBATTERY EQUATION)

The Vforward maximum is depending on the present Vbattery. The graph in fig. 1 shows the coherence of the Vbattery and the maximum allowable Vforward.

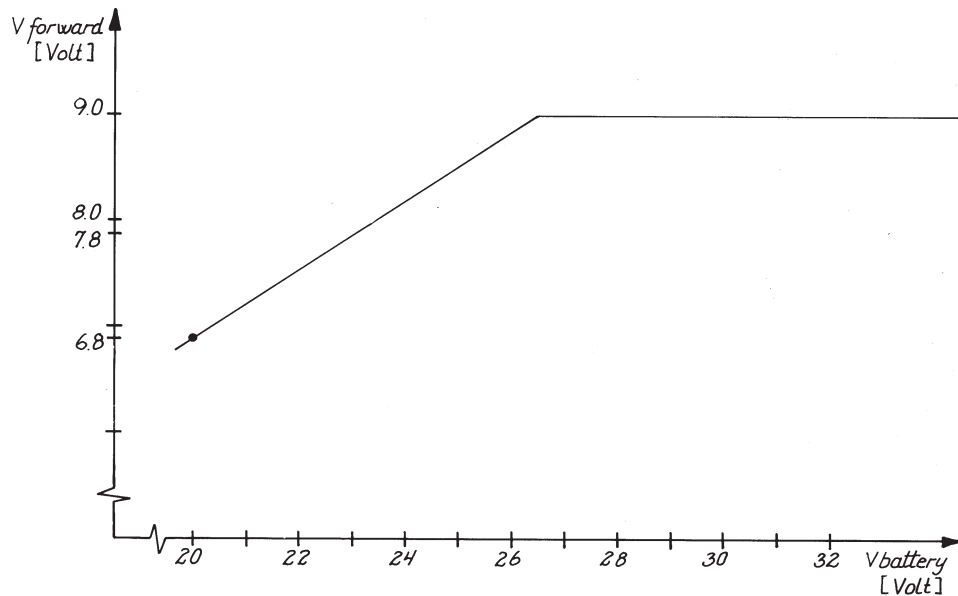

26190

Fig. 1. Nominal values of Vbattery, Vforward maximum.

The graph consists of two linear parts. Part 1 is valid for a Vbattery < 26.5 Volt and has the following equation:

$$Vf_max1 = 0.33 * Vbattery + 0.20 \text{ (Volt)}$$

Part 2 is valid for a Vbattery >= 26.5 Volt and has the following equation:

$$Vf_max1 = 9.00 \text{ (Volt)}$$

Vbattery is measured by the TX-processor. This is described in section **2.3.3.5. CALIBRATION OF THE T2130.**

Vf_max2

The addition due to the result of the calibration may be either positive or negative. The principles for the calibration of the T2130 are described in section **2.3.3.5. CALIBRATION OF THE T2130.**

Vf_max3

This addition is made in order to reduce the variations in the gain in the Power Amplifier (1) and the variations in the loss in the Output Filter (2).

The addition may either be positive or negative. There are 6 different additions which may be added. One for each frequency range covered by the lowpass filters in the Output Filter Module (2). The addition for the frequency range 1.6 - 2.599 MHz is always 0 as 1.6 MHz is used as a reference.

Vf_max4

This is in fact not an addition. It is possible to reduce the RF PEP power out of the transmitter in a few steps by means of the Service Programmes.

When the power is not reduced the Vf_max4 has a value which is always higher than Vf_max5.

When the power is reduced the Vf_max4 has a fixed value corresponding to the selected PEP power level.

2.3.3.3 TUNING THE AT2110

The tuning may take place in 3 different procedures:

- Uptune, where a tuning is done from basic data.
- Retune, where the tuning is done from data saved at the latest Uptune.
- No tune, which is done when there is no AT2110 in the system (jumper 5 is inserted).

UPTUNE PROCEDURE

This is the basic tune procedure for tuning the AT2110. The conditions for an uptune procedure are the following:

- 'TX TUNE' is entered on the keyboard on the RE2100.
- The frequency has not been tuned before. This means that there is no valid data in the EEPROM's for the specific 200 kHz band in which the frequency is.
- The retune procedure did not work out. The retuning could not be done with the data saved in the EEPROM's. The measured Standing Wave Ratio (SWR) was too high. The aerial conditions may have been changed since the latest uptune of a frequency in the 200 kHz band concerned, or the data saved in the EEPROM's are deleted by use of the Service Programmes.

The uptuning may take place in up to 6 states. The states are sequently executed until the uptuning is accepted.

1. The relays in the AT2110 are set so the RF-signal is fed straight through the coupler. This means that no resonance (inductance, (L)) or load (capacitance, (C)) is active. If the SWR (Standing Wave Ratio) is better than or equal to 2.0 the tuning of the aerial is accepted. A possible previously saved combination is deleted from the EEPROM's.

If jumper 4 on the TX-processor (3) is inserted this 'signal straight through' combination will NOT be tested.

2. A sequence of shifting the resonance and the load in a certain pattern is run through. For each frequency band (200 kHz) a number of combinations of fixed resonance values (L) and fixed load values (C) are switched in. For every combination of a fixed resonance and a fixed load the variable capacitor is run through the working range. Within the working range of the variable capacitor the SWR is measured and compared continuously to certain limits.

The first combination always contains the highest value of the resonance (most L is in) and the lowest value of the load (least C is in).

The next combinations contain each a decreasing value of the resonance and the lowest value of the load.

When the lowest value of resonance has been tested the next higher value of load is switched in and all the resonance values are tested again.

The variable capacitor is activated by the tune motor MO1. The motor may run at high speed or at low speed. In the following mentioned as 'high tune speed' and 'low tune speed'.

With the tune speed high the SWR is measured and compared continuously to the following limits and different actions may take place:

$1.0 < \text{SWR} \leq 1.5$.

The actual combination of resonance and load is kept and the tune speed is changed to low. The variable capacitor is run through its variation range again. When the SWR limit is passed again, the tune motor is stopped immediately and the tuning is accepted. The found combination of resonance and load and the SWR limit are saved in the EEPROM's for a later retune procedure.

$1.5 < \text{SWR} \leq 2.0$

The actual combination of resonance and load is remembered by the processor in order to tune with the low speed later.

$2.0 < \text{SWR} \leq 2.5$.

The actual combination of resonance and load is remembered together with a flag indicating that the SWR is in the range $2.0 < \text{SWR} \leq 2.5$ by the processor in order to tune with the low speed later.

3. If no combination could give an $\text{SWR} \leq 1.5$ the remembered combinations giving an $\text{SWR} \leq 2.0$ are tested at low tune speed.

The SWR is measured and compared to the following limits and different actions take place:

$1.5 < \text{SWR} \leq 1.7$.

The tune motor is stopped immediately and the tuning is accepted.

The found combination of resonance and load and the SWR limit are saved in the EEPROM's for a later retune procedure.

4. If no combination could give an $\text{SWR} \leq 1.7$ the remembered combinations giving an $\text{SWR} \leq 2.0$ are tested again at low tune speed.

The SWR is measured and is now compared to the following limit:

$1.7 < \text{SWR} \leq 2.0$

The tune motor is stopped immediately and the tuning is accepted.

The found combination of resonance and load and the SWR limit are saved in the EEPROM's for a later retune procedure.

5. If no combination could give an $\text{SWR} \leq 2.0$ the remembered combinations giving an SWR in the range $2.0 < \text{SWR} \leq 2.5$ are tested at low tune speed.

The SWR is measured and is compared to the following limit:

$\text{SWR} \leq 2.5$.

The tune motor is stopped immediately and the tuning is accepted.

6. If no combination could give an $\text{SWR} \leq 2.5$ the AT2110 relays are set to feed the RF-signal straight through the coupler and this is then accepted as an uptune. When the transmitter is keyed the RF-power is reduced accordingly to the actual SWR.

RETUNE PROCEDURE

This is the tune procedure normally used. The conditions for a retune procedure are the following:

- A frequency within the same 200 kHz band has been tuned previously to an SWR ≤ 2.0 . This means that valid data are read out of the EEPROM's and the aerial conditions have not changed essentially.

The data saved in the EEPROM's for a retune are divided into 142 elements. Each element equals a frequency band covering 200 kHz. For each 200 kHz band a relay combination and a code for the tuned SWR are saved.

The principles for a retune procedure are described in the following.

Data concerning the actual 200 kHz are read out of the EEPROM's and validated.

If the code for the SWR is not acceptable an uptune procedure is started immediately.

If the code for the SWR is valid then the codes for the SWR and the relays are converted. The specific relays are activated.

With the tune speed low the SWR is measured and compared continuously to the limit which is read out from the EEPROM's.

The SWR limit is 1.5 or 1.7 or 2.0. The retune procedure will then always try to tune to the same SWR limit as the untune procedure. If however, this is not possible the retune will try to tune to the next higher limit. If it is not possible to tune to an SWR ≤ 2.0 the uptune procedure is started immediately.

NO TUNE PROCEDURE

This procedure is run only when there is no AT2110 connected to the T2130. In fact the jumper 5 on the TX-processor (3) must be inserted.

The only purpose for this routine is to measure the SWR and if the SWR ≤ 2.0 inform the RE2100 and the user.

2.3.3.4 TRANSMIT SUPERVISING

The motives for the supervising are as follows:

- Protection of the Transmitter T2130 against high SWR (bad aerial conditions).
- Protection of the power transistors in Power Amplifier (1) against damage caused by high temperature.
- Ensuring that the transmitter T2130 does always deliver maximum RF-power with a minimum of intermodulation regardless of variations in the battery voltage supplying the Power Amplifier (1).

When the Transmitter T2130 is keyed, certain parameters are watched by the TX-processor (3) and action is taken if the change of the parameters is essential. The following parameters are watched:

- SWR, Standing Wave Ratio
- Supply voltage to the Power Amplifier (1)
- Temperature in the Power Amplifier (1).

In general a change of any of the watched parameters causes a control of the RF-level input to the Power Amplifier.

While the transmitter is keyed the TX-processor has the full control of the digitally controlled step attenuator in the Exciter Unit (4) in the RE2100 via the SP-Bus and the Processor Unit (5) in the RE2100.

Each of the watched parameters results in a number of steps. The steps are simply added to the step found when the Automatic Power Setting was performed.

$$\text{act_step} = \text{APS_step} + n1 + n2 + n3$$

Where:

- act_step = actual step for the attenuator
- APS_step = the step found at the Automatic Power Setting
- n1 = deviation step related to SWR
- n2 = deviation step related to Temperature
- n3 = deviation step related to Battery Voltage

The subsections below describe each of the parameters watched.

SWR WATCHING

When the T2130 is transmitting, the SWR is continuously watched. This means in terms that the TX-processor (3) measures the Rho approx. 2500 times per second.

Note: Rho and SWR are two expressions describing the same physics.

$$\text{Rho} = \frac{\text{SWR} - 1}{\text{SWR} + 1} \quad \text{SWR} = \frac{1 + \text{Rho}}{1 - \text{Rho}}$$

The measured Rho is compared to two limits.

If $\text{SWR} > 2.0$ ($\text{Rho} > 0.333$) then a calculation takes place. The result of the calculation gives a number of 0.3 dB steps with which the RF-signal has to be reduced. The number of steps n1 is given by:

$$n1 = \frac{(\text{Rho} - 0.333) * 18}{0.3} \quad (\text{n1 cannot be negative}).$$

If $\text{SWR} > 5.0$ then the error message 'Bad SWR' is generated. The operator is informed when the key is released.

TEMPERATURE WATCHING

The temperature at the power transistors in the Power Amplifier (1) is measured 4 times per second. The measured temperature is compared to two limits. If the temperature is above 98° Celcius a calculation takes place.

The result of the calculation gives a number of 0.3 dB steps with which the RF-signal has to be reduced. The number of steps n2 is given by:

$$n2 = \frac{\text{Measured temperature} - 98^{\circ}\text{C}}{2} \quad (\text{n2 cannot be negative})$$

This means that a temperature increase of 20°C to 118°C reduces the RF power approx. 3 dB.

If the temperature is above 118° Celcius the Power Amplifier (1) is blocked and the RF-power is reduced further approx. 60 dB. An error message is generated and when the key is released the operator is informed.

When the temperature has fallen to 100° Celcius the Power Amplifier (1) is opened again.

SUPPLY VOLTAGE WATCHING

The battery voltage is measured 4 times per second. The battery voltage is measured as described in section **2.3.3.5. CALIBRATION OF THE T2130.**

A Vforward maximum (Vf_max) is found as described in section **2.3.3.2. AUTOMATIC POWER SETTING.** The Vf_max is compared to the maximal Vforward (Vf_max_tun) found when the Automatic Power Setting was performed. When there is a certain difference (in dB) the step attenuator is controlled accordingly.

As there is a certain compressing of the RF-signal in the Power Amplifier (1) a certain change (in dB) of the Vf_max (due to a change in the battery voltage) will give a small change of the input RF-signal to the Power Amplifier. This means that if the supply voltage has increased so much that the Vf_max is 0.6 dB higher than the Vf_max found at the Automatic Power Setting, the RF-input level must be increased by 0.3 dB.

The number of steps (n3) the step attenuator has to be changed due to change in the supply voltage is calculated in the following way:

$$n3 = \frac{(Vf_max_tun - Vf_max) / Vf_max_tun}{10(0.6/20) - 1} \quad (n3 \text{ can be negative, zero, or positive}).$$

In order to prevent fast oscillating in the automatic control of the step attenuator a decrease of the step due to higher battery voltage is delayed a few seconds.

2.3.3.5 CALIBRATION OF THE T2130

In practice the calibration is done by means of a Service Programme. Please refer to the Service Programmes. In the following the calibration is described functional.

MOTIVE FOR THE CALIBRATION

The calibration is done in order to eliminate tolerances in specific components related to the measuring of the battery voltage and the Vforward voltage.

PRINCIPLES FOR THE CALIBRATION

The principle for the calibration is as follows. With a given battery supply voltage the RF-output is increased until a specific distortion is reached. The battery voltage and the corresponding Vforward are measured and the differences between the measured and the nominal values are calculated.

NECESSARY SIGNALS AND PARAMETERS

- Vbattery. This is measured by the TX-processor (3). The technique used by the TX-processor to measure the 24 Volt battery is discussed in a separate subsection below.
- Vforward. This is measured by the TX-processor (3).
- Nominal values. This covers the coherence between the battery supply voltage and the maximum allowable Vforward. For the description of the graph please refer to the subsection 'Calculating Vforward maximum' in section **2.3.3.2. AUTOMATIC POWER SETTING.**

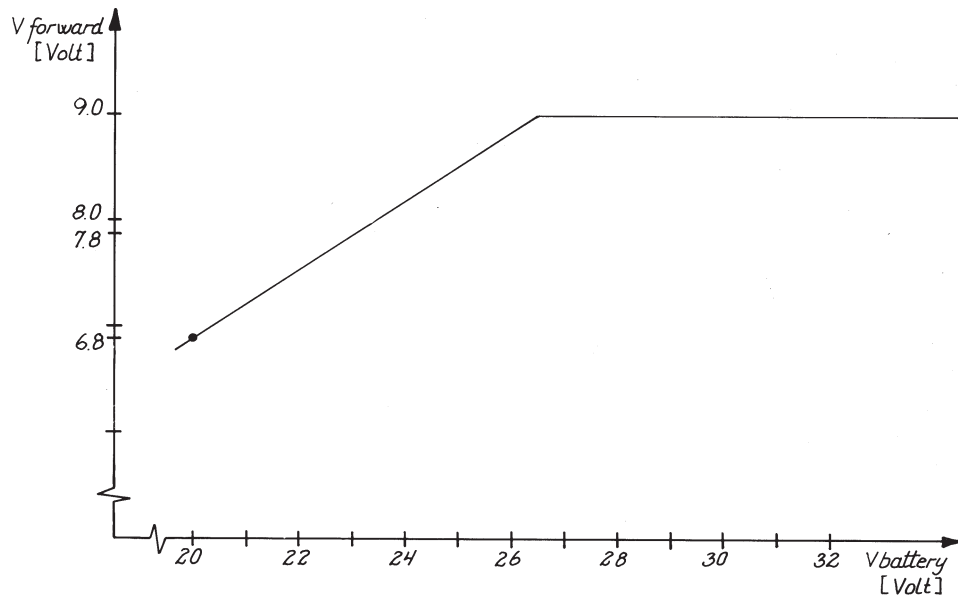

26190

Fig. 2. Nominal values of the Vbattery, Vforward maximum.

FUNCTIONAL DESCRIPTION OF THE CALIBRATION

A Vbattery = 24,000 Volt must be present at the '+' and the '-' 24 Volt battery terminals on the Connection Board (6).

The Service Programme for calibrating ensures that the two tone RF-signal is present at the internal dummy load in the T2130. The level of the two RF-signal is now increased by use of the keyboard on the RE2100 until specific requirements for the intermodulation is just fulfilled.

At this point the TX-processor is ordered to measure the actual battery voltage and the actual Vforward voltage. When this is done some calculations take place.

Concerning the Vbattery an offset is calculated. This offset is the difference between the nominal Vbattery and the measured Vbattery.

Concerning the Vforward an offset is calculated. The offset is mentioned in the subsection above as Vf_max2.

Vf_max2 is the difference between the nominal value of Vf_max1 at Vbatt = 24,000 Volt and the measured Vforward.

MEASURING THE BATTERY VOLTAGE

As the battery is galvanic isolated from the ground it is not possible for the TX-processor to measure the battery voltage direct.

The TX-processor (3) is measuring the voltage '+24V Sense' and an offset is added. The offset added is a result of the calibration described in section **2.3.3.5. CALIBRATION OF THE T2130.**

In the Power Supply (4) the '+24V Sense' is generated.

The DC to DC converter in the Power Supply is working after the 'Pulse Width Modulation' principle. The peak voltage on the secondary turn of the isolation transformer is then proportional to the voltage switched on the primary turn. The '+24V Sense' is then proportional to the battery voltage.

In the Service Programmes the measured '+24V Sense' is converted to voltage and read out to the display on the RE2100.

The relation between the battery voltage and the '+24V Sense' is determined empirical and is given by the following equation:

$$\text{'24V Sense'} + \text{Cal_offset} = \text{Vbattery} * 1.31 - 0.95 \text{ (Volt)}$$

giving:

$$\text{Vbattery} = \frac{\text{'24V Sense'} + \text{Cal_offset} + 0.95}{1.31} \quad \text{(Volt)}$$

CONTENTS

3	SERVICE	
3.1	MAINTENANCE	3-1
3.2	ALIGNMENT INSTRUCTIONS	3-1
3.3	PROPOSAL FOR NECESSARY MEASURING INSTRUMENTS	3-1
3.4	TROUBLE SHOOTING	3-2
3.4.1	POWER AMPLIFIER (MODULE 1)	3-5
3.4.2	OUTPUT FILTER (MODULE 2)	3-6
3.4.3	TX-PROCESSOR (MODULE 3)	3-7
3.4.4	POWER SUPPLY (MODULE 4)	3-8
3.4.5	NOT USED	3-10
3.4.6	CONNECTION BOARD (MODULE 6)	3-10
3.4.7	REPLACEMENT OF COMPONENTS	3-10
3.4.8	REPLACEMENT OF MODULES	3-10
3.5	PERFORMANCE CHECK	3-11
3.5.1	POWER AMPLIFIER (MODULE 1)	3-12
3.5.2	OUTPUT FILTER (MODULE 2)	3-13
3.5.3	TX-PROCESSOR (MODULE 3)	3-14
3.5.4	POWER SUPPLY (MODULE 4)	3-19
3.5.5	NOT USED	3-20
3.5.6	CONNECTION BOARD (MODULE 6)	3-20
3.6	ADJUSTMENT PROCEDURE	3-21
3.6.1	POWER AMPLIFIER (MODULE 1)	3-21
3.6.2	ADJUSTMENT OF OUTPUT FILTER (MODULE 2)	3-21
3.6.3	ADJUSTMENT OF DRIVE LEVEL	3-21
3.7	NECESSARY ADJUSTMENTS AFTER REPAIR	3-23

3.7.1	MODULES REPLACED	3-23
3.7.2	COMPONENTS REPLACED	3-24
3.8	FUNCTION CHECK	3-25
3.8.1	FUNCTION CHECK FOR THE TRANSMITTER INSTALLED	3-25
3.8.3	BATTERY CHECK	3-25
3.8.4	OUTPUT POWER CHECK	3-25
3.8.5	SWR CHECK	3-25
3.8.6	CHECK OF POWER GAIN IN PA-MODULE (1)	3-25
3.8.7	END OF SERVICE PROGRAMME	3-25
3.9	SERVICE PROGRAMMES	3-27
3.9.1	SERVICE PROGRAMMES IN T2130	3-27
3.9.2	SERVICE PROGRAMMES RELATED TO AT2110	3-32

3 SERVICE

3.1 MAINTENANCE

PREVENTIVE MAINTANANCE

If SAILOR T2130 has been installed in a proper way the maintenance can be reduced to an overhaul at each visit of the service staff.

Then inspect the set, the antenna, cables, and plugs for mechanical damages, salt deposits, corrosion, and any foreign material.

Owing to its traditional structure, the SAILOR T2130 has a long lifetime, but it must always be carefully checked at intervals not exceeding 12 months - dependent on the conditions under which the set is working.

Along with each set a TEST-SHEET is delivered in which all the measurements, made in the test department of the factory, are listed. If the control measurings made in the service workshop should not show the same values as those listed in the test-sheet, the set must be adjusted as specified in chapter 3.6. ADJUSTMENT PROCEDURE.

3.2 ALIGNMENT INSTRUCTIONS

INTRODUCTION

The measuring values indicated in chapter 5. CIRCUIT DESCRIPTION AND SCHEMATIC DIAGRAMS are typical values and as indicated it will be necessary to use instruments in absolute conformity with the below list:

3.3 PROPOSAL FOR NECESSARY MEASURING INSTRUMENTS

Tone Generator type PM5107	PHILIPS
Electronic Multimeter type PM2505	PHILIPS
RF Directional Wattmeter Model 43	BIRD
250W Load with type	BIRD
Oscilloscope type PM3216	PHILIPS
Dummy load 50 ohm/250W	
Power Supply 21-32V, 20A	

3.4 TROUBLE SHOOTING

SAILOR Compact HF SSB system has built-in self-diagnostic service system, which is a great help in locating a fault.

When a fault is detected an error message will be displayed in the RE2100 display.

The following description will help you to find the defective unit or module.

Trouble-shooting should only be performed by persons with sufficient technical knowledge, who have the necessary measuring instruments at their disposal, and who have carefully studied the operation principles and structure of SAILOR T2130.

The first thing to check is whether the fault is somewhere in the antenna circuit or power source.

When measuring in the units, short-circuits must be avoided as the transistors would then be spoiled.

LOCATING THE FAULTY MODULE

ERROR MESSAGES, DESCRIPTION

The error messages displayed in the RE2100 display are technically described in the following.

70. MOTOR CIRCUIT ERROR (AT2110)

An error is detected in the circuitry controlling the tune motor MO1 in the AT2110. The TX-processor has not detected the '180° pulse' from the AT2110.

The error may be one of several possibilities:

If the tune motor MO1 starts running immediately after the power is switched on at the RE2100:

- Check the level of the '180° PULSE/AE-CURRENT' at ST01 pin 3, on the Connection Board (6) in T2130.

If the level is high (approx. 15 Volt):

The error is probably in the AT2110:

- Check the '180° PULSE/AE-CURRENT' connection between T2130 and AT2110.
- Check the '180° PULSE/AE-CURRENT' connection in the AT2110.
- Check the light in the optocoupler OC01 on the Main Board (1) in the AT2110. This may be done by measuring the voltage drop across the resistor R26 in the Connection and Interface module (3) in the AT2110.

If the level is low:

The error is probably in the T2130:

- Check the '180° PULSE/AE-CURRENT' connection between the Connection Board (6) and the TX-processor (3) in the T2130.

If the tune motor MO1 does NOT start running immediately after the power is switched on at the RE2100:

- Check the voltage at ST01 pin 7 when the power is tuned on at RE2100. The voltage should be approx. 16 Volt.

If the 16 Volt is ok:

The error is probably in the AT2110:

- Check the connection to the tune motor MO1 in AT2110.
- Check the 'Motor +' connection between the T2130 and the AT2110.

If the 16 Volt is NOT present:

The error is probably in the T2130:

- Check the connection between the TX-processor (3) and the Connection Board (6) in T2130.

71. VFORWARD LOW

The level of the Vforward voltage is low (< 0.7 Volt) measured at the output of the SWR detector on the Output Filter (2).

SP-22-0 displays the latest measured Vforward.

The RF-signal is probably

72. VFORWARD HIGH

The level of the Vforward voltage is high.

SP 22-0 displays the latest measured Vforward.

Check the output level of the Exciter Unit (4) in the RE2100.

The error may also occur if the T2130 has been improperly calibrated.

73. HIGH SWR IN THE TUNING OF THE AT2110

It is not possible to tune the AT2110 to an SWR better than 2.5.

- Check the aerial.
- Check the RF-signal path from the Power Amplifier (1) in the T2130 to the aerial.
- Check the SWR detector on the Output Filter (2). Please refer to section 3.4.2. in the instruction manual for T2130.

74. TRANSMITTER TEMPERATURE HIGH

Ensure a free air flow at the bottom and at the top of the T2130 chassis.

SP 21-0 displays the state of the temperature protection function. Please refer to the Service Programmes.

- Check the idle current in the Power Amplifier (1). Please refer to section 3.4.1. in the instruction manual for T2130.
- Check the temperature measuring circuit. Please refer to section 3.5.3.1. A/D CONVERTER in the instruction manual for T2130.

75. HIGH SWR WHEN TRANSMITTING

This error may occur if the aerial has become bad since the latest uptune on the frequency or has become bad during a transmit period.

SP-23-0 displays the latest measured SWR.

76. BATTERY VOLTAGE LOW

The Power Amplifier (1) has been blocked due to low battery voltage.

During the period of the automatic power setting or when the transmitter has been keyed, the battery voltage has been measured to be lower than approx. 18 Volt.

- Check the battery, specially the charging state.
- Check the cable installation from the battery to the Connection Board (6) in the T2130.

If the error has appeared because of an error in the measuring circuit, please refer to section 3.5.3.1. A/D CONVERTER, +24 Volt Sense Measuring, in the instruction manual for T2130.

77. TEMPERATURE SENSOR ERROR

The temperature is measured to be very high or very low, indicating an error in the temperature measuring circuit. Please refer to section 3.5.3.1. A/D CONVERTER, Temperature Measuring in the instruction manual for T2130.

78. INTERNAL SWR TOO HIGH

The SWR in the internal dummy load used for the automatic power setting is higher than certain limits. For frequencies lower than 20 MHz the SWR is 1.2. For frequencies above 20 MHz the SWR limit is 1.6. Please refer to the circuit description for the Output Filter (2) section 3.4.2. in the instruction manual for T2130.

3.4.1 POWER AMPLIFIER (MODULE 1)

Connect a 50 ohm load to RF in/out (ST04) on the Connection Board (6).

3.4.1.1 ERROR 71. VFORWARD LOW

This means that there is no output from the PA-module.
Select service programme SP-29, see section 3.9.1.

3.4.1.2

Check the RF-input level on the PA-module (1).
Approx. 1.2 Vpp.

3.4.1.3

Check the RF-output level on the PA-module (1).
Approx. 200 Vpp.

3.4.1.4

Check of bias. Note only when the output is zero. See chapter 3.6. ADJUSTMENT PROCEDURE, sections 3.6.1.1 to 3.6.1.4.

3.4.1.5

If the measurement above is ok, then the fault is probably to be found in the Output Filter (2).

3.4.1.6 ERROR 74. TRANSMITTER TEMPERATURE HIGH

The temperature on the output transistors is too high.

3.4.1.7

Check that there are free air circulation around the transmitter and the ambient temperature is not more than 40°C. If the temperature is higher the performance will be reduced.

3.4.1.8

Check R45 (temperature sensor) located on one of the screws holding Q10 (see component location for Power Amplifier (1) in chapter 5.1). When it is 25°C the resistance is 2.00 Kohm.

3.4.1.9

Check if the output transistors have a good thermal contact to the heatsink.

IMPORTANT! Always use thermal compound for the power transistors. (e.g. Wakefield part No. 120-8 or equivalent).

3.4.2 OUTPUT FILTER (MODULE 2)

3.4.2.1 ERROR 71. VFORWARD LOW

3.4.2.2

Check if the error comes up on all frequencies (one in each filter). Fault is probably in relay RE14-2 or in the cabling from module 2 to the Connection Board (6).

If the error only comes up in one filter, check the input/output relays (eg. RE01-2, RE07-2), and then the filter capacitors.

3.4.2.3

Check of the Vforward detector.

Select service programme SP-29, see chapter 3.9.

3.4.2.4

Measure the RF-output voltage on the Connection Board (6) with an oscilloscope approx. 200 Vp-p. Then check the DC voltage on U01/1 pin 1 approx. 6.5V.

3.4.2.5 ERROR 78. INTERNAL SWR TOO HIGH

3.4.2.6

Check R27 and R28 (the power resistors to the left of module 6) with an ohmmeter value 50 ohm $\pm 10\%$.

3.4.2.7

Check relay RE14.

3.4.2.8 ERROR 73 AND 75

Connect a 50 ohm load to the output terminal on the Connection Board (6).

Select service mode SP-29, see chapter 3.9.

3.4.2.9

Check Vforward U1 pin 1 approx. 6.5 V
 Vreverse U1 pin 7 approx. 10.5 mV.

3.4.2.10

IF Vforward and Vreverse are ok. Then the fault is in TX-Processor (3)

3.4.3 TX-PROCESSOR (MODULE 3)

Check all incoming and outgoing voltages.

A. Supply voltages. Measured with voltmeter.

Incoming:	Pin	Plug	Meas. ref.
GND	1,2,3	6	
+5 Volt A	6	6	GND
+5 Volt B	7	6	GND
-5 Volt	5	6	GND
+15 Volt	10	6	GND
-15 Volt	9	6	GND
+18 Volt	11	6	GND
OVA	9	5	Battery minus
+21 Volt	1	5	OVA

Outgoing:	Pin	Plug	Meas. ref
GND	10,11,12	4	
+15 Volt	9	4	GND

B. Signal voltages.

Incoming	Pin	Plug	Please see section
Vforward	7	4	3.5.3.1. A/D CONVERTER
Vreverse	8	4	3.5.3.1. A/D CONVERTER
AE-current	3	5	3.5.3.5. AE-CURRENT, Vf.cond.
180o pulse	3	5	3.4. ERROR MESSAGES (70)
Man. Tune	10	5	3.5.3.10.MANUAL TUNE
+24V sense	4	6	3.5.3.1. A/D CONVERTER
Temperature	13,14	6	3.5.3.1. A/D CONVERTER

Outgoing:	Pin	Plug	Please see section
Control 1-6	1-6	4	3.5.3.2. OUTPUT FILTER DRIVER
RX/TX	13	4	3.5.3.2. OUTPUT FILTER DRIVER
RX-TX/drive	14	4	3.5.3.2. OUTPUT FILTER DRIVER
TLX on/off	2	5	3.5.3.4. TELEX OPEN
Mute	4	5	3.5.3.2. OUTPUT FILTER DRIVER
Clock	5	5	3.5.3.6. AT2110 DRIVER
Data	6	5	3.5.3.6. AT2110 DRIVER
Vf/AE-current	8	5	3.5.3.3. AE-CURRENT, Vf.Cond.
RF on/off	8	6	3.5.3.3. RF ON/OFF

3.4.4 POWER SUPPLY (MODULE 4)

3.4.4.1

If all output supplies are missing, check the main fuses F02 and F03 (20A) located on the Connection Board (6).

3.4.4.2

If only the +18V, -18V, +9V are missing the fault is in the switch mode power supply.

3.4.4.3

Check the voltage on U01 pin 13, 12V (heatsink as common).

3.4.4.4

If zero voltage, check fuse F01 (3.15A) on the Connection Board (6).

3.4.4.5

If it is ok, disconnect the gate and source on switching Fet's on Q02 and Q03.

3.4.4.6

Then check the waveforms on U01 pin 11 and 12, see below.

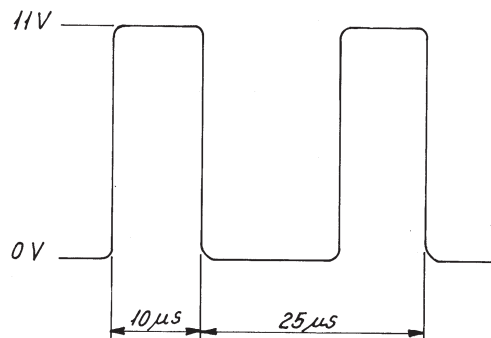

3.4.4.7

If not ok, then the fault is in U01.

3.4.4.8

If ok, then reconnect the gate and source and check the waveforms on U01 pin 11/12, see below.

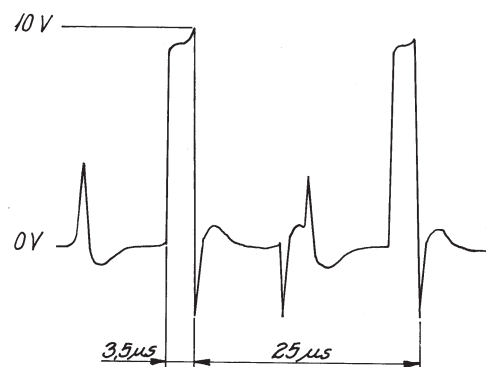

3.4.4.9

If the waveforms look like that, the drain/source current is too high, Check for a defect rectifier diode or a defect regulator (U02 to U06).

3.4.4.10

If the waveforms look like under point 3.4.4.6, then Q2 or Q3 is defect, It might also be a fault in the feed-back circuit (D23, OC01)

3.4.5 NOT USED

3.4.6 CONNECTION BOARD (MODULE 6)

No hints.

3.4.7 REPLACEMENT OF COMPONENTS

When replacing transistors, diodes, resistors, capacitors and similar components you must use a small „pencil“ soldering iron of 30 to 75 Watt rating. The soldering must be performed rapidly to avoid overheating, and the use of a tin sucker is recommended, as otherwise there is a risk that both the components and the printed circuit will be spoiled.

After replacement of components look-up the chapter 3.7.2 COMPONENTS REPLACED.

3.4.8 REPLACEMENT OF MODULES

If a fault has been found in a module, it may often be worthwhile to replace it and then repair it later on. After replacement of a module look-up the chapter 3.7.1 MODULES REPLACED.

3.5 PERFORMANCE CHECK

All tests are done with an RE2100 connected, and a supply voltage of exactly 24.00V.

In the subsections in this section is referred to the following test set-up modes:

Mode 1: Standby. Receive mode, with aerial connected.

Mode 2: 50 ohm dummy load connected to the output of T2130. Jumper 5 is inserted into plug PO2-5 in the TX-processor (3) in the T2130.

Mode 3: 50 ohm dummy load connected to the output of the AT2110.

3.5.1 POWER AMPLIFIER (MODULE 1)

Presettings. Note 2.

3.5.1.1 BIAS CURRENT

Select service programme SP-33, see section 3.9.1.

3.5.1.2

Connect an ammeter (F.S. 100 mA) in series with P1, and check that the current is 80 mA \pm 30 mA.

3.5.1.3

Select normal receive mode. Check that the current is zero.

3.5.1.4

Connect an ammeter (F.S. 1A) in series with P2, and check that the current is 450 mA \pm 100 mA.

3.5.1.5

Select normal receive mode. Check that the current is zero.

3.5.1.6 POWER GAIN.

Select service programme SP-29, see section 3.9.1.

3.5.1.7

Connect an oscilloscope with 1:10 probe (0.2V/div) across J01. Adjust the level to 1 Vpp by means of the buttons 'up' and 'down'.

3.5.1.8

Connect the oscilloscope with 1:10 probe (20V/div) to J02. Check that the level is 170 Vpp \pm 50V.

3.5.1.9 CHECK OF FULL POWER OUTPUT

Select normal transmit mode, frequency approx. 1.6 MHz. Connect the handset to RE2100.

3.5.1.10

Connect an oscilloscope with 1:10 probe (50V/div) to J02.

3.5.1.11

Key the transmitter and whistle into the microtelephone- Check that the level is more than 245 Vpp.

3.5.1.12

Select a transmitter frequency near to 25 MHz.

3.5.1.13

Key the transmitter and whistle into the microtelephone. Check that the level is more than 228 Vpp.

3.5.2 OUTPUT FILTER (MODULE 2)

Presettings. Note 2.

3.5.2.1 SWR-DETECTOR

Select service programme SP-29, see section 3.9.1.

3.5.2.2

Adjust the output to 200 Vpp across the external 50 ohm load by means of the buttons 'up' and 'down'.

3.5.2.3

Check that the voltage on pin 7, U01 is less than 400 mV.

3.5.2.4

Check that the voltage on pin 1, U01 is 6.3V \pm 0.5V.

3.5.2.5 FILTER SECTION

Select service programme SP-11, see section 3.9, and note the last digit. Then press 1 <ENT>. The display will now show 'SP-11-1'.

Select service programme SP-12 and note the last digit. Then press 3 <ENT>. The display will now show 'SP-12-3'.

Press <TUNE> and select H3E mode.

3.5.2.6

Check the output power for each filter in the low and high end in accordance with the table below. Key the transmitter by means of the handset key.

Low Frequency kHz	High Frequency kHz	Max. Power Difference dB
1605	2599	1
2600	4199	1
4200	6799	1
6800	11099	1
11100	18099	1.4
18100	29999	1.7

3.5.2.7

When the test is finished do the following.

Select service programme SP-11. Then key-in the noted digit and press <ENT>.

Select SP-12 and key-in the noted digit and press <ENT>. Then press <TUNE>.

3.5.3 TX-PROCESSOR (MODULE 3)

3.5.3.1 A/D CONVERTER

REFERENCE VOLTAGE

Test set-up: Mode 1.

- A. Connect a Voltmeter to pin 13 on U15, (4053).
Voltage is +2.5 Volt +/- 1.5%.
- B. Connect a Voltmeter to pin 7 on U16/2, (TL072).
Voltage is +5.0 Volt +/- 1.7%.

VFORWARD MEASURING

Test set-up: Mode 2.

- A. Select a frequency near 1650 kHz.
Connect a voltmeter to the upper end of R56, (3K92). Key the microphone and whistle into the microphone. Note the voltmeter reading (approx. 10V) Release the key while whistling.
- B. Enter SP-22-0.
Compare the displayed Vforward to the measured voltage. Maximum deviation from the measured voltage is +/-4%.

SWR MEASURING

Test set-up: Mode 2.

- A. Enter SP-29.
Connect a Voltmeter to the upper end of R56, (3K92). Vforward voltage should be approx. 7.3 Volt DC.
- B: Connect a Voltmeter to the upper end of R65, (3K92). Vreverse voltage should be approx. 0.12 Volt DC. Leave SP-29 by entering the 'ENT' key.
- C: Calculate the SWR.

$$SWR = \frac{V_{forward} + V_{reverse}}{V_{forward} - V_{reverse}}$$

- D. Enter SP-23-0 >ENT<.
Compare the displayed SWR to the calculated voltage. Maximum deviation from the calculated is +12%/-5%.

+24 VOLT SENSE MEASURING

Test set-up: Mode 2.

- A. Connect a Voltmeter to the upper end of R63, (15K4).
- B: Enter SP-29. Read the voltmeter. Leave SP-29 by entering 'ENT'. Calculate the battery voltage:

$$V_{battery} = \frac{\text{' +24 Volt Sense' } + 0.95}{1.31}$$

Enter SP-20-0 >ENT<.

- C: Compare the displayed battery voltage to the calculated voltage. Maximum deviation from the calculated is +/-5%.

NOTE: This is just checking the measuring circuit - NOT the absolute battery voltage present at the Connection Board (6).
The special sequence of SP-29 followed by SP-20-0 may give a different battery voltage compared to a normal read of SP-20-0 caused by an offset added by the calibration of the T2130.

TEMPERATURE MEASURING

Test set-up: Mode 1.

- A: Disconnect the PO1 on the Power Supply (4). This is the cable to the temperature sensor R45 on the Power Amplifier (1).
Connect a resistor of 2 Kohm on the PO1 on the Power Supply (4).
B: Connect a Voltmeter to the lower end of R60, (8K2). Voltage is 2.5 Volt +/-1.7% +/- tolerances on the 2 Kohm resistor.
C: Calculate an adctemp:

$$\text{adctemp} = \frac{\text{Measured voltage} * 255}{5.0 \text{ Volt}}$$

- D: Enter SP-21-1 >ENT<.
Multiply the displayed result by 10. Compare to the calculated adctemp. Maximum deviation is +/- 2%.
E: Reconnect temperature sensor to P.S. module P01

3.5.3.2 OUTPUT FILTER MODULE DRIVERS

RX/TX RELAY DRIVER

Test set-up: Mode 1.

- A: Enter SP-29. Connect the voltmeter to U09 pin 16. Voltage is <1.1 Volt. Leave SP-29 by entering 'ENT'.

TX/DRIVE RELAY DRIVER

Test set-up: Mode 1.

- A: Enter SP-29. Connect the voltmeter to U08 pin 16. Voltage is < 1.1 Volt. Leave SP-29 by entering 'ENT'.

OUTPUT FILTER RELAY DRIVERS

Test set-up: Mode 2.

Each of the six drivers controls two relays for switching in the lowpass filters.

- A: Key in a TX-frequency in the frequency range for the specific filter.

FREQUENCY RANGE	PIN ON U08
1.6 - 2.599 MHz	14
2.6 - 4.199 MHz	12
4.2 - 6.799 MHz	10
6.8 - 11.099 MHz	11
11.1 - 18.099 MHz	13
18.1 - 30.000 MHz	15

- B: Connect the voltmeter to the specific pin on U08.
C: Key the transmitter. Voltage is < 1.1 Volt.

3.5.3.3 RF ON/OFF

Test set-up: Mode 1

- A: Connect a voltmeter to the collector of Q11 or at P06 pin 8.
 B: Key the transmitter. Voltage is < 0.8 Volt.

3.5.3.4 TELEX OPEN

Test set-up: Mode 1

- A: Connect pin 6 ST03 on the Connection Board (6) to ST02 pin 16 SP-BUS INTERRUPT, and connect pin 5 ST03 to ST02 pin 4 +18V.
 B: Connect a voltmeter to the collector of Q10.
 C: Select „TLX“ mode on the RE2100 and key the transmitter.
 Check that Q10 is on (low).
 D: Select „J3E“ mode on the RE2100.
 Check that Q10 is off (high).

3.5.3.3 AE-CURRENT/VFORWARD CONDITIONING**AE-CURRENT**

Test set-up: Mode 1. Turn „RF“ fully clockwise.

- A: Connect a voltmeter to ST02 pin 2 on the Connection Board (6).
 B: Disconnect the wire at pin 3 at ST01 on the Connection Board (6) and connect a variable power supply to pin 3 at ST01 with a 1 Kohm in series (negative terminal to chassis).
 C: Vary the power supply and check the voltmeter according to the table below:

Vin (ST01, pin 3):	Vout (ST02, pin 2):
0.0V	0.87V ±10%
5.0V	4.27V ±10%
10.0V	7.77V ±10%
15.0V	8.00V ±10%
18.5V	9.80V ±10%

VFORWARD

Test set-up: Mode 1.

- A: Insert jumper 5 in the TX-processor.
 B: Switch off/on the RE2100.
 C: Connect a voltmeter to U06 pin 7 or at ST02 pin 2 on the Connection Board (6).
 D: Key the transmitter and modulate. Read the voltmeter. Voltage follows the modulation.
 E: Remove the jumper.

3.5.3.6 AT2110 DRIVER**CLOCK DRIVER**

Test set-up: Mode 2.

- A: Connect an oscilloscope (0.5 msec/div, 5 Volt/div) to ST01, pin 5 on the Connection Board (6), ground to ST01, pin 10.
 Voltage is low, < approx. 1 Volt.
 B: Set the RE2100 to scan two frequencies, one below 3900 kHz, and the other above 4100 kHz.
 24 clock pulses appear. The high level is approx. +21 Volt.

DATA DRIVER

Test set-to: Mode 2.

- A: Connect an oscilloscope, (0.5 msec/div, 5 Volt/div) to ST01, pin 6 on the Connection Board (6), ground to ST01, pin 10.
- B: Set the RE2100 to scan two frequencies, one below 3900 kHz, and the other above 4100 kHz.
One data pulse appears. The high level is approx. +21 Volt.

3.5.3.7 EEPROM'S

- A: See Service Programme SP-24-0.

3.5.3.8 SP-BUS

Test set-up: Mode 1.

- A: Ensure that exactly two termination jumpers are inserted in two of the units connected to the SP-Bus.
- B: Switch on the power on the RE2100.
If 'Error 20' is NOT displayed, the SP-Bus is working.
If 'Error 20' appears on the RE2100, the RE2100 cannot establish the communication link to the T2130.
- C: Check the cable connection between the RE2100 and the TX-processor (3) in the T2130.
- D: Ensure that jumper 1 (the leftmost) is removed on TX-processor (3).

RECEIVER

Test set-up: Mode 1.

- A: Remove the SP-Bus cable from J01 on the TX-processor (3).
- B: Connect an oscilloscope.
Ch 1 to the left end of L01. (2 Volt/div), ground to chassis.
Ch 2 at pin 3 on U05 (74HC08). (2 Volt/div), ground to chassis.
- C: Connect a variable power supply to J01 instead of the SP-Bus, chassis as reference.
- D: Vary the voltage from +5 Volt to -5 Volt and reverse. Check the trigger voltage = +/- 3 Volt +/-10%.

DRIVER

Test set-up: Mode 1.

It is assumed that the receiver is checked and found ok.

- A: Connect an oscilloscope. 0.5 msec/div.
Ch 1 to U04 pin 5 as trigger+ (Driver Enable). (2 Volt/div), ground to chassis.
Ch 2 to or with a 'T' on the SP-Bus. (2 Volt/div), ground to chassis.
- B: Let the RE2100 scan two frequencies, one below 3900 kHz, the other above 4100 kHz. Remove the aerial from RE2100.
- C: Check the output levels for the driver when the TX-processor 'answers' the RE2100.
Levels: Positive: +4.0 up to 4.8 Volt.
Negative: -4.0 down to -4.8 Volt.

3.5.3.9 TUNE MOTOR CONTROL

HIGH SPEED

Test set-up: Mode 1.

A: Connect a voltmeter (positive) at pin 7 at ST01, negative at pin 10 at ST01 on the Connection Board (6).

B: Switch off and on the RE2100.

The tune motor is then being reset at high speed. The motor runs approx. 1.5 sec. Voltage is approx. 16 Volt.

LOW SPEED

Test set-up: Mode 1.

A: Enter SP-32-3 >ENT<.

Connect a voltmeter to pin 7 motor + and to pin 10, 0 VA.

Check that the voltage is approx. 8 Volt.

3.5.3.10 MANUAL TUNE

Test set-up: Mode 1.

A: Connect a voltmeter at pin 23 on U02 (HD63B03Y).

B: Toggle the 'Manual Tune' switch on the Connection Board (6). High level voltage = approx. 5 Volt.

Low level voltage < 0.5 Volt.

3.5.3.11 MICROPROCESSOR

RESET

Test set-up: Mode 1.

A: Check the +5 Volt B supply at pin 1 and 2 on U03 (MAX690). Voltage = 5 Volt +/- 0.25 Volt.

B: Check the value at pin 6 on U02 (HD63B03Y). Voltage is above the +5 Volt B minus 0.5 Volt.

BATTERY LOW DETECTOR

Test set-up: Mode 1.

A: Check the +18 Volt supply at the upper end of R01 (22K1). Voltage >17.3 Volt.

B: Check the 'Power fail output' at pin 5 on U03 (MAX690). Voltage >4.5 Volt.

WATCH DOG

Test set-up: Mode 1.

A: Connect an oscilloscope to the 'watch dog input' at pin 6 on U03 (MAX690). (0.2 sec/div and 2 Volt/div). Check that the level is shifted for every 0.8 sec. If it is not, then the microprocessor does not execute the programme properly.

3.5.4 POWER SUPPLY (MODULE 4)

3.5.4.1

Check of supply voltages to RE2100.

Check the voltages on the Connection Board (6) in accordance with the table below.

Pin No.	Name	Lower limit	Upper limit
3	+9V	8V	10V
4	+18V	18V	20V
14	-18V	-18V	-20V
16	GND		

3.5.4.2

Check of supply voltages to TX-Processor (3).

All voltages are with GND as reference. Note the heatsink is connected to -battery (0VA) and is not grounded.

U02, Vout = +5V \pm 5%
 U03, Vout = +5V \pm 5%
 U04, Vout = +15V \pm 5%
 U05, Vout = -15V \pm 5%
 U06, Vout = -5V \pm 5%

3.5.4.3

Check of supply voltage to the AT2110 aerial coupler.

The voltage is measured on the Connection Board (6).

ST1 pin 1 to pin 10 22V \pm 2V.

3.5.4.4

Check of supply voltage to PA-amplifier (1) with input (battery) voltage = 24.0V.

Check that the collector supply to the output transistors at PO2 on module 1 is 23.7V \pm 0.2V. (Heatsink as negative reference).

3.5.4.5

Key the transmitter and whistle in the microphone. The collector voltage must not drop more than max. 0.5V.

3.5.4.6

With input (battery) voltage 30V, check that the collector supply to the output transistors at PO2 on module 1 is 27.25V \pm 0.75V.

3.5.4.7

Check of audio amplifier U07.

Connect an 8 ohm load to loudspeaker output on the Connection Board (6) ST3 No. 15 and 16.

Connect an audio generator 1700 Hz, 300 mVpp to ST2 No. 7 and 8 (AF to AMP common, AF to AMP).

3.5.4.8

Check with an oscilloscope that the output across the 8 ohm is undistorted and has a peak to peak value of 17V \pm 3V.

3.5.5 NOT USED

3.5.6 CONNECTION BOARD (MODULE 6)

3.5.6.1 MUTE RX OUT

Key the transmitter with the microtelephone key.

3.5.6.2

Check by means of an ohmmeter that there is contact from ST03 pin 1 to 2.

3.5.6.3 MUTE RX IN

Connect a power supply +15V from pin 11 to pin 12 on ST03.

3.5.6.4

Check that the receiver is muted.

3.5.6.5 TX-KEY AND RF ON/OFF

Only if supplied with telex.

3.5.6.6

Select TLX mode on RE2100.

3.5.6.7 TX-KEY

Connect pin 3 on ST03 to GND and pin 4 to +18V on ST02 pin 4.

3.5.6.8

Check that the relays on the Output Filter (2) are activated.

3.5.6.9 RF ON/OFF

Connect also pin 5 on ST03 to GND and pin 6 to +18V on ST02 pin 4.

Connect an audio generator (1700 Hz, 760 mV) to pin 9 and pin 10 on ST03.

3.5.6.10

Check that the transmitter is now transmitting with full power

3.6 ADJUSTMENT PROCEDURE

3.6.1 POWER AMPLIFIER (MODULE 1)

3.6.1.1 ADJUSTMENT OF ZERO SIGNAL CURRENT

Presettings:

- Turn R14 and R30 fully counter clockwise.
- Disconnect P3 (driver supply) and P2 (output transistor supply).
- Select service programme SP-33, see chapter 3.9.1.

3.6.1.2 ADJUSTMENT OF DRIVER ZERO SIGNAL CURRENT

Connect an ammeter (F.S. 100 mA) in series with J01 and P01. Adjust R14 to a meter reading of 80 mA.

3.6.1.3 ADJUSTMENT OF THE OUTPUT TRANSISTOR ZERO SIGNAL CURRENT

Connect an ammeter (F.S. 1A) in series with J02 and P02. Adjust R30 to a meter reading of 450 mA.

NOTE! the current will be drifting the first minute or so.

3.6.1.4

After adjustment of zero signal currents connect the plugs P3 and P2.

3.6.2 ADJUSTMENT OF OUTPUT FILTER (MODULE 2)

3.6.2.1 INITIAL SETTINGS:

Select service programme SP-25, see chapter 3.9.1.

3.6.2.1 ADJUSTMENT OF SWR DETECTOR

Adjust C31 to minimum voltage on U01 pin 7 (must be less than 0.7V).

NOTE! the transmitter is only transmitting for 2 secs, then it is off for 2 secs and so on. You can only adjust C31 when the transmitter is transmitting.

3.6.3 ADJUSTMENT OF DRIVE LEVEL

3.6.3.1 INITIAL SETTINGS:

- Connect an oscilloscope with 1: 10 probe (50V/div) across R27 module 2.
- Select service programme SP-25, see chapter 3.9.1.
- Adjust input voltage to 24.00V.

3.6.3.2

By means of the buttons   adjust the signal, so that flat topping

just occurs on the oscilloscope.

IMPORTANT! the input voltage (battery supply) must be 24.00V for calibration.

Then press  to store the drive level setting. See also chapter 3.9.1.

3.7 NECESSARY ADJUSTMENTS AFTER REPAIR

3.7.1 MODULES REPLACED

3.7.1.1 POWER AMPLIFIER (MODULE 1)

Adjust the Power Amplifier (1) as described in section 3.6.1.

Perform a calibration of T2130. Please refer to chapter 3.9. SERVICE PROGRAMMES, SP-25.

3.7.1.2 OUTPUT FILTER (MODULE 2)

Adjust the Output Filter (2) as described in section 3.6.2.

3.7.1.3 TX-PROCESSOR (MODULE 3)

New module delivered direct from S. P. Radio A/S:

Calibrate the T2130. Please refer to section 3.9. SERVICE PROGRAMMES, SP-25.

An exchanged module:

1. Check the EEPROM's by entering SP-24-0.
2. Initialize the EEPROM's by entering SP-24-2.
3. Calibrate the T2130. Please refer to chapter 3.9. SERVICE PROGRAMMES, SP-25.

3.7.1.4 POWER SUPPLY (MODULE 4)

No adjustments.

3.7.1.6 CONNECTION BOARD (MODULE 6)

No adjustments.

3.7.2 COMPONENTS REPLACED

3.7.2.1 POWER AMPLIFIER (MODULE 1)

After replacing the components, perform adjustment procedure section 3.6.1 POWER AMPLIFIER and 3.6.3 ADJUSTMENT OF DRIVE LEVEL.

3.7.2.2 OUTPUT FILTER (MODULE 2)

After replacing the components in the filter section, no adjustment is necessary.

After replacing components in the directional coupler, perform adjustment procedure section 3.6.2 ADJUSTMENT OF OUTPUT FILTER (MODULE 2) and 3.6.3 ADJUSTMENT OF DRIVE LEVEL.

3.7.2.3 TX-PROCESSOR (MODULE 3)

U11 or U12:

1. Test the replaced EEPROM's for read and write.
Please refer to chapter 3.9 SERVICE PROGRAMMES, SP-24-0.
2. Initialize EEPROM's from scratch.
Please refer to chapter 3.9 SERVICE PROGRAMMES, SP-24-1.
3. Calibrate the T2130.
Please refer to chapter 3.9 SERVICE PROGRAMMES, SP-25.

U17:

1. Calibrate the T2130. Please refer to chapter 3.9 SERVICE PROGRAMMES, SP-25.

3.7.2.4 POWER SUPPLY (MODULE 4)

No adjustment necessary.

3.7.2.6 CONNECTION BOARD (MODULE 6)

No adjustment necessary.

3.8 FUNCTION CHECK

The function check is divided into two sections, one for the transmitter installed and one for the transmitter at your workshop.

3.8.1 FUNCTION CHECK FOR THE TRANSMITTER INSTALLED

3.8.2

Select the lowest transmitting frequency and press <TX> <TUNE>. When the tune lamp extinguishes, press the handset key and whistle into the microphone. While whisteling release the handset key.

3.8.3 BATTERY CHECK

Press <1> and <0> simultaneously. The display will now show 'SP-'.
Then key <200> <ENT>.

The TX display will now show what the battery voltage was when transmitting (must be more than 22V).

3.8.4 OUTPUT POWER CHECK

Key <222> <ENT>.

The TX display shows the latest measured Vforward (must be more than 9V).

3.8.5 SWR CHECK

Key <230> <ENT>.

The TX display shows the SWR (must be better than 2).

3.8.6 CHECK OF POWER GAIN IN PA-MODULE (1)

Key <261> <ENT>.

The TX display shows the drive setting (must be more than 12).

3.8.7 END OF SERVICE PROGRAMME

Key <TUNE>.

3.8.8

Check that it is possible to tune and to transmit in all marine bands.

3.8.9

Make a control call to a coast station.

3.8.10 FUNCTION CHECK AT WORKSHOP

Connect a 50 ohm load in series with a Bird in line power meter and a power supply 28V, 20A.

3.8.11

Perform function check 3.8.2 to 3.8.7.

3.8.12 OUTPUT POWER CHECK

Make a power check in each marine band.

Check, by whistling into the microphone, if the power is within the limits given below.

	Low limit	High limit
1.6 - 3.8	158 W	270 W
4 MHz band	158 W	270 W
6 MHz band	158 W	270 W
8 MHz band	158 W	270 W
12 MHz band	158 W	270 W
16 MHz band	158 W	270 W
18 MHz band	158 W	270 W
22 MHz band	158 W	270 W
25 MHz band	130 W	270 W

3.8.13 MODULATION CHECK

Connect an oscilloscope across the load, modulate the transmitter with speech.

3.8.14

Check that the signal looks allright.

3.9 SERVICE PROGRAMMES

In the following it is assumed that the Service Programme jumper is inserted in the RE2100. In general, if the RE2100 displays 'Err.0' in a Service Programme, the selected SP does not exist.

Example:

Operator: Key: 20-7 <ENT>
RE2100: Displays: 'SP-20-7'
 ' Err.0'

Legend: Err.0 = The entered service programme does not exist.

3.9.1 SERVICE PROGRAMMES IN T2130

SP-20-0

Displays the latest measured Vbattery voltage.

Example:

Operator: Key: 20-0 <ENT>
RE2100: Displays: 'SP-20-0'
 ' 25.3'

Legend: Measured in Volt

SP-20-1

Measures and displays the present Vbattery voltage.

Example:

Operator: Key: 20-1 <ENT>
RE2100: Displays: 'SP-20-1'
 ' 26.2'

Legend: Measured in Volt.

SP-21-0

Displays the state of the temperature protection.

Example:

Operator: Key: 21-0 <ENT>
RE2100: Displays: 'SP-21-0'
 ' 00.1'

Legend: 00.0 There has been no reduction of Vforward due to high temperature.
 00.1 There has been a reduction of Vforward due to high temperature.
 00.2 The Power Amplifier has been blocked due to very high temperature.

SP-22-0

Displays the latest measured Vforward voltage.
The voltage is only valid after the transmitter has been keyed.
Example:

Operator: Key: 22-0 <ENT>
RE2100: Displays: 'SP-22-0'
 ' 10.7'

Legend: Measured in Volt

SP-22-1

Measures and displays the present Vforward.
Example:

Operator: Key: 22-1 <ENT>
RE2100: Displays: 'SP-22-0'
 ' 10.9'

Legend: Measured in Volt.

SP-22-2

Displays the latest measured Vforward maximum voltage.
The voltage is only valid after the transmitter has been keyed.
Example:

Operator: Key: 22-2 <ENT>
RE2100: Displays: 'SP-22-0'
 ' 11.2'

Legend: Measured in Volt.

SP-23-0

Displays the latest measured SWR.
Example:

Operator: Key: 23-0 <ENT>
RE2100: Displays: 'SP-23-0'
 ' 1.6'

SP-23-2

Displays the measured SWR when the tuning has finished.
Example:

Operator: Key: 23-2 <ENT>
RE2100: Displays: 'SP-23-0'
 ' 1.7'

SP-24-0

Tests the EEPROM's for write and read.

Example:

```
Operator:      Key:      24-0 <ENT>
RE2100:      Displays:  'SP-24-0'
---
---
RE2100:      Displays:  'SP-24-0'
                          ' A. '
Legend:      A.   = No errors found
              Err.1 = Error found in U11
              Err.2 = Error found in U12.
```

NOTE! the duration of the test is approx. 8 seconds.

SP-24-1

Deletes all stored Retune Data from the EEPROM's.

Example:

```
Operator:      Key:      24-1 <ENT>
RE2100:      Displays:  'SP-24-1'
---
---
RE2100:      Displays:  'SP-24-1'
                          A.
Legend:      A.   = Deleting finished
```

SP-24-2

Initializes EEPROM's from scratch. Stores standard data in the EEPROM.

Example:

```
Operator:      Key:      24-2 <ENT>
RE2100.      Displays:  'SP-24-2'
---
---
RE2100:      Displays:  'SP-24-1'
                          A.
Legend:      A.   = Initializing finished.
```

NOTE! The T2130 must be turned off and on after the execution of this Service Programme. The T2130 **MUST** be calibrated after this Service Programme.

SP-25

Calibrates the T2130.

Example:

Operator: Connect an oscilloscope to the internal Dummy Load in the T2130.

Operator: Connect a Voltmeter to the battery supply pins at the Connection Board (6) in the bottom of the T2130.

Operator: Key: 25
 RE2100: Displays: 'SP-25-'
 ' CAL.'

RE2100: Delivers a two-tone RF-signal continuously (same as tune tones).
 TX-frequency: 1600.0 kHz.

T2130: Opens and closes for the two-tone RF-signal. Open for 2 seconds and
 closed for 2 seconds.

Operator: Ensure continuously that the battery voltage is 24.0 Volt in the open period.

Operator: Adjust the RF-level of the two-tones by using the keys <FREQ UP>
 and <FREQ DOWN> until the RF-signal on the oscilloscope is just not distorted.

Operator: Key: 1 <ENT>
 RE2100: Displays: 'SP-25-1'
 ' A.'

Legend: A. = Accepted. T2130 is calibrated.
 Err. 1 = Battery voltage is high. Please check.
 Err. 2 = Battery voltage is low. Please check.
 Err. 3 = Forward Voltage is high. See the description of Error Message 72.
 Err. 4 = Forward Voltage low. See the description of Error Message 71.
 Err. 5 = Bad SWR in the internal dummy load.

Note! If any 'Err.' comes up the T2130 is **NOT** calibrated.

UNINTENTIONAL CALL OF SP-25

If the operator unintentionally has keyed '25' it is possible to leave Service Programme 25 without calibrating the T2130 in the following way:

Operator: Key: <ENT> or <TUNE>

SP-25 may also be left by switching off the power on the RE2100.

SP-26-0

Displays the maximum step of the Step Attenuator in the RE2100 Exciter.

Example:

Operator: Key: 26-0 <ENT>
 RE2100: Displays: 'SP-26-0'
 ' 14.'

SP-26-1

Displays the actual step of the Step Attenuator in the RE2100 Exciter.

Example:

Operator: Key: 26-1 <ENT>
 RE2100: Displays: 'SP-26-1'
 ' 18.'

SP-27

Displays the version and the release of the software in the TX-processor (3) in the T2130.

Example:

Operator: Key: 27-0 <ENT>
RE2100: Displays: 'SP-27-0'
 ' 1083.A'

Legend: '1083' is S. P. Radio's identification of the version of the software.
 On the label of the
 EEPROM is written: C1083A.

' ' = 1. release
'A' = 2. release
'B' = 3. release
etc.

SP-28

Sets RF-power level (reduced power).

Power levels: 0 = Normal, 250 W
 1 = 150 W
 2 = 125 W
 3 = 100 W

Example:

Operator: Key: 28-(0-3)<ENT>
 'SP-28-(0-3)'

RE2100: Displays: 'SP-28-2'
 ' 125. '

Legend: 125. = Set to 125 W.

SP-29

Trouble shooting service programme.

Example:

Operator: Key: 29
RE2100: Displays: 'SP-29-0'
 ' SE. '

RE2100: Delivers a two-tone RF-signal continuously (same as tune tones).
 TX-frequency: 1600.0 kHz.

T2130: The corresponding lowpass filter is switched in and the transmitter is keyed.
 It is advisable to connect a 50 ohm dummy load instead of the aerial coupler.

Operator: May now trouble shoot the transmitter without being disturbed by error messages etc.
 Adjustment of the RF-level of the two-tones is done by using the keys <FREQ UP>
 and <FREQ DOWN>. When the trouble shooting is finished:

Operator: Key: <ENT>
RE2100: Displays: 'SP-29-0'
 ' A. '

SP-33

Adjustment of the bias current in the power transistors in the Power Amplifier (1).

Example:

Operator: Key: 33
RE2100: Displays: 'SP-33-0'
 ' SE. '

T2130: The transmitter is keyed.
 There are no RF-signals applied to the Power Amplifier (1).

Operator: May now adjust the bias current in accordance with the adjustment procedure.
 When the adjustment is finished:

Operator: Key: <ENT>
RE2100: Displays: 'SP-33-0'
 ' A. '

3.9.2 SERVICE PROGRAMMES RELATED TO AT2110**SP-30**

Activates AT2110 relays 1-9 one by one, and releases any relay.

Example:

Operator: Key: 30 - (0-9) <ENT>
RE2100: Displays: 'SP-30-(0-9)'
 ' A. '

Legend: 0 = No relays activated.
 1-9 = Relays 1-9 activated.
 A. = Accepted.

The T2130 activates the entered AT2110 relay no., other relays are released.

SP-31

Activates AT2110 relays 10-19 one by one.

Example:

Operator: Key: 31 - (0-9) <ENT>
RE2100: Displays: 'SP-31-(0-9)'
 ' A. '

Legend: 0-9 = Relays 10-19 activated.
 A. = Accepted.

The T2130 activates the entered AT2110 relay no., other relays are released.

If the AT2110 is in the system (jumper 5 is inserted in the TX-processor) the following is displayed:

RE2100: Displays: 'SP-25 '
 ' Err.1 '

SP-32-0

Resets the AT2110 'Clock' line, 'Data' line and the 'Motor +' line to their normal state.

Example:

Operator: Key: 32 - 0 <ENT>
RE2100: Displays: 'SP-32-0'
 ' A. '

SP-32-1

Sets the AT2110 clock line high.

Example:

Operator:	Key:	32 - 1 <ENT>
RE2100:	Displays:	'SP-32-1' ' A. '

SP-32-2

Sets the AT2110 data line high.

Example:

Operator:	Key:	32-2 <ENT>
RE2100:	Displays:	'SP-32-2' ' A. '

SP-32-3

Sets supply on the AT2110 'Motor +' line, (low speed).

Example:

Operator:	Key:	32 - 3 <ENT>
RE2100:	Displays:	'SP-32-3' ' A. '

--

CONTENTS

- 4 MECHANICAL DISASSEMBLING**
- 4.1 MECHANICAL DISASSEMBLING AND MODULE LOCATION 4-1

4 MECHANICAL DISASSEMBLING

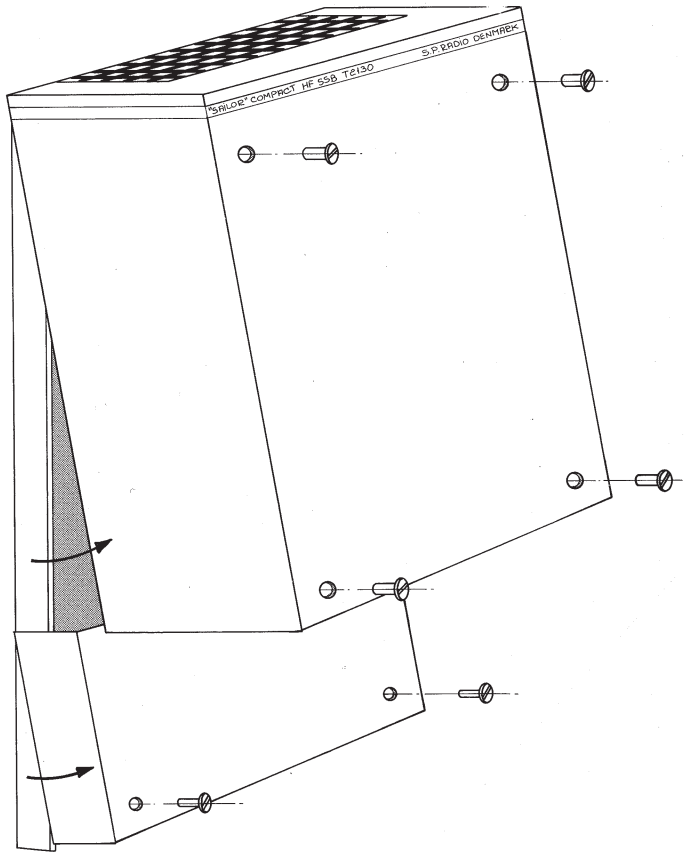

4-0-25892

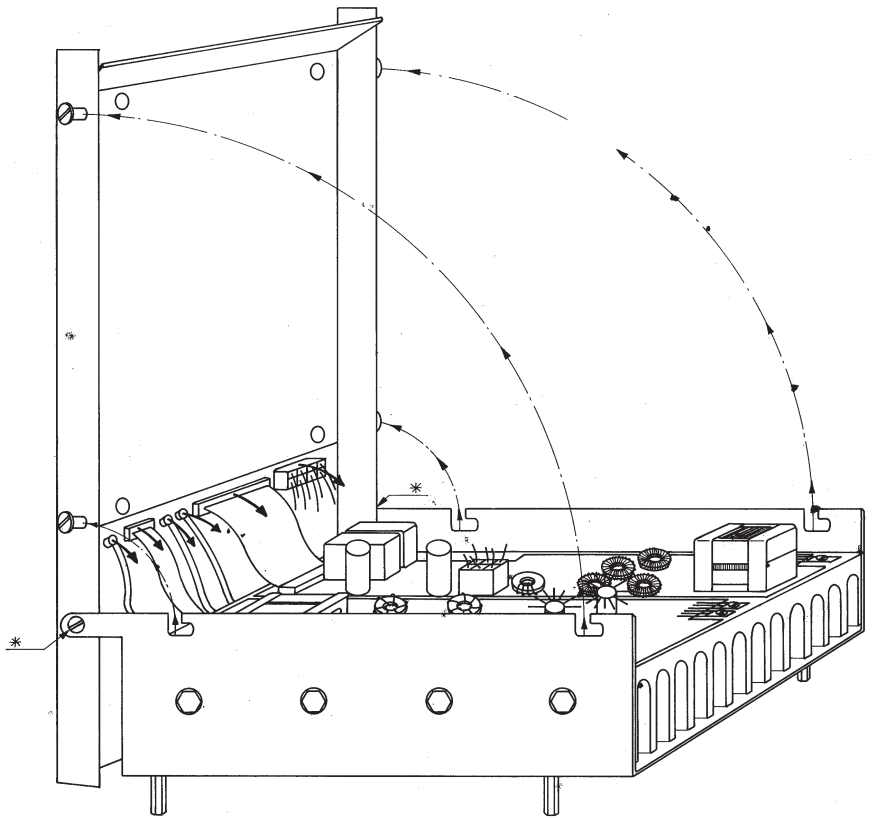

4-0-25893

After disconnecting all cables on the connection board, remove the inner chassis by dismounting the 2 screws marked *

4.1 MECHANICAL DISASSEMBLING AND MODULE LOCATION

FOTO NO. 50995, 50997, 501009, 501010, 501012, 501041, 501042, 501043, 501045,

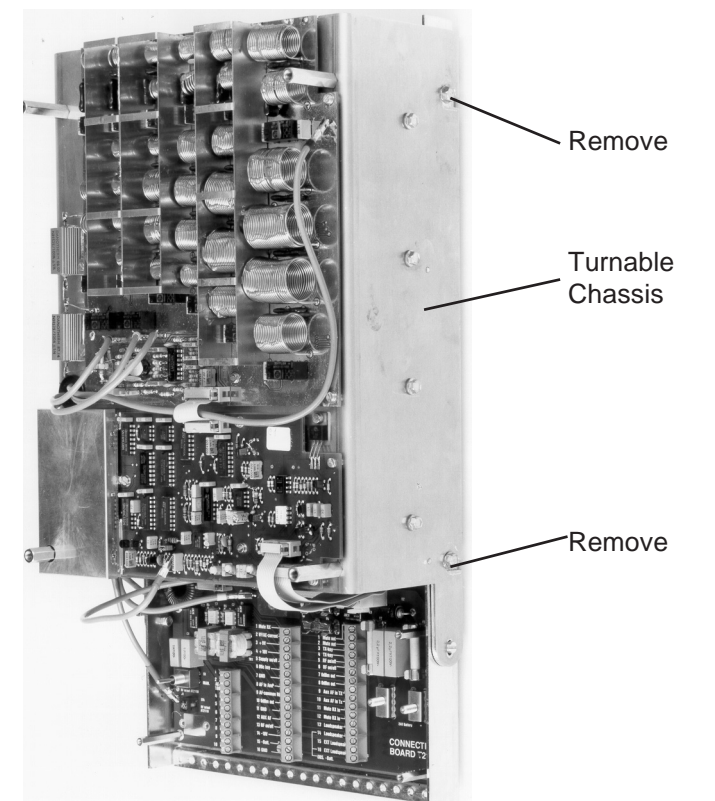
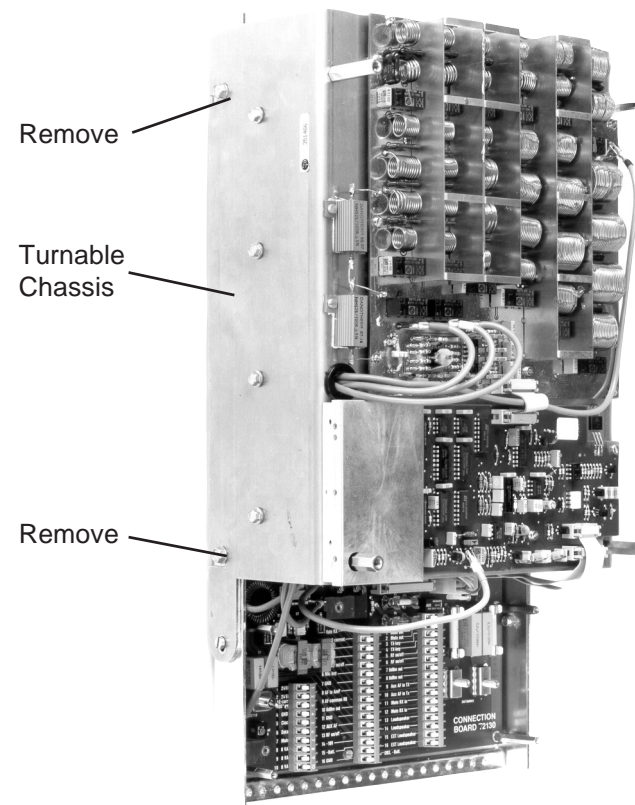
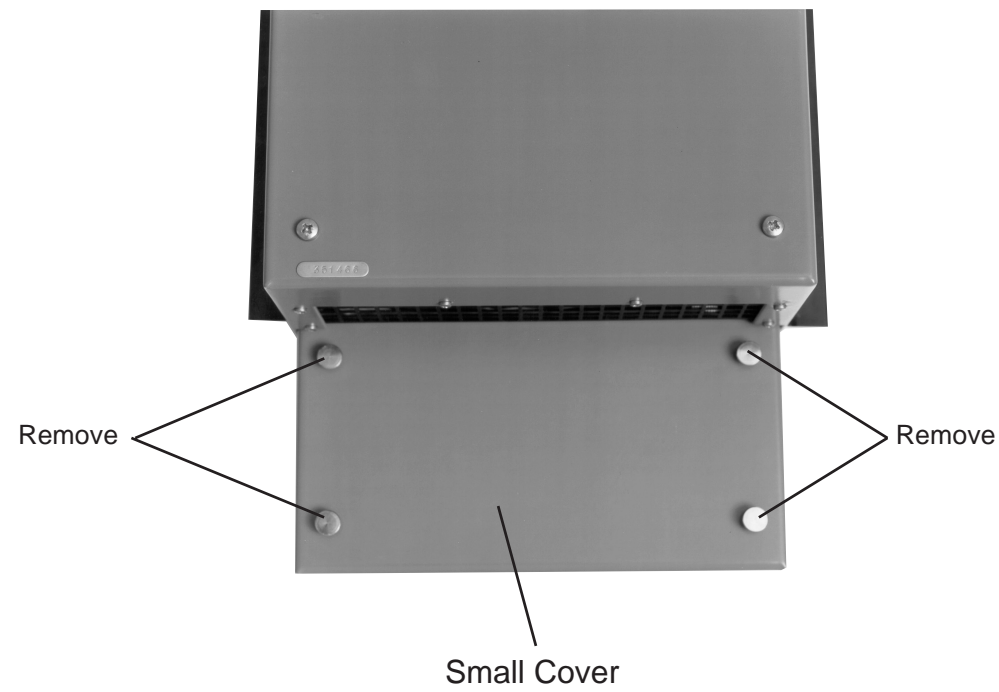
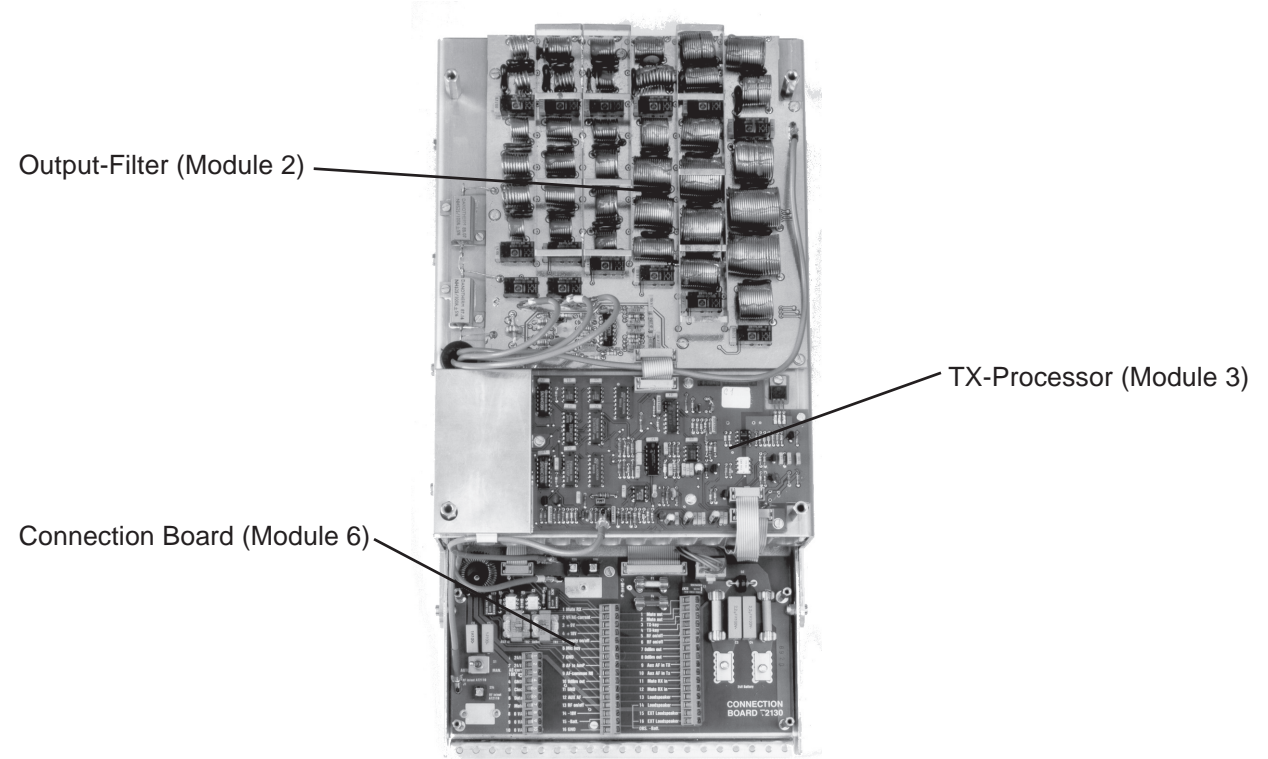
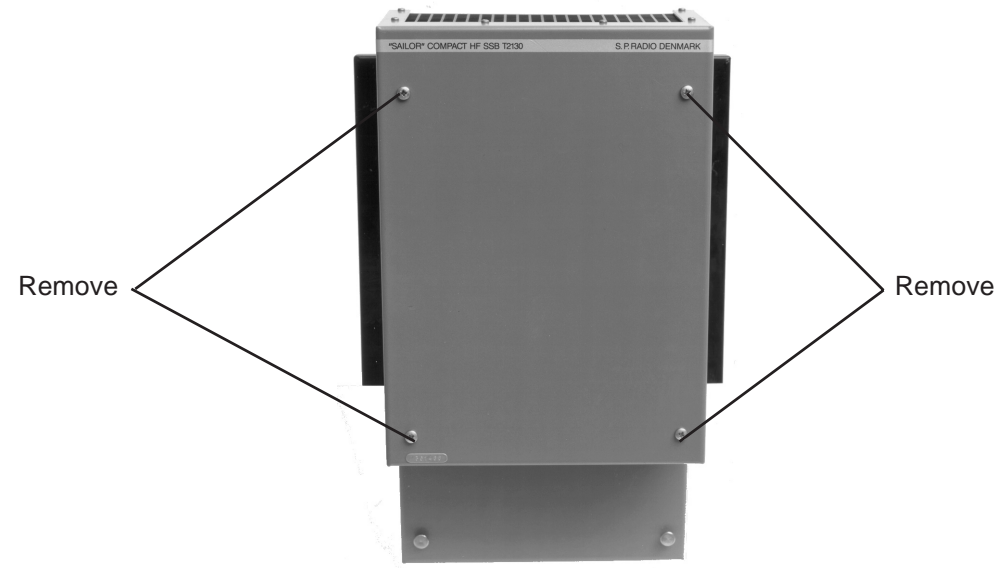

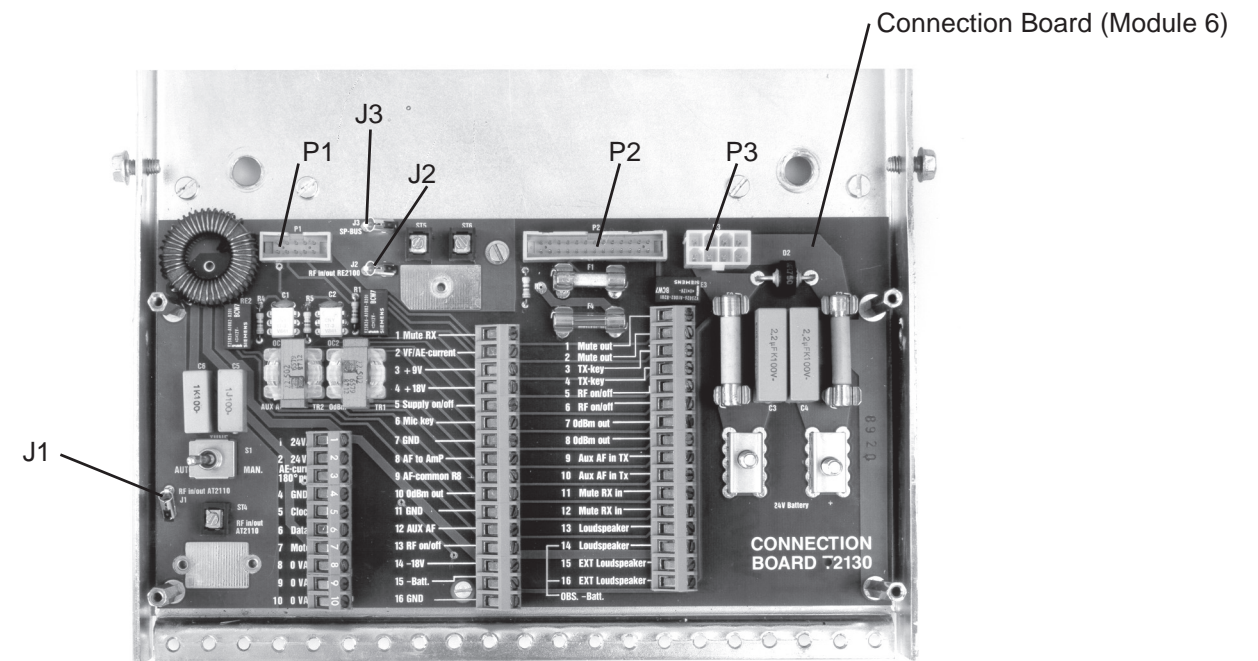
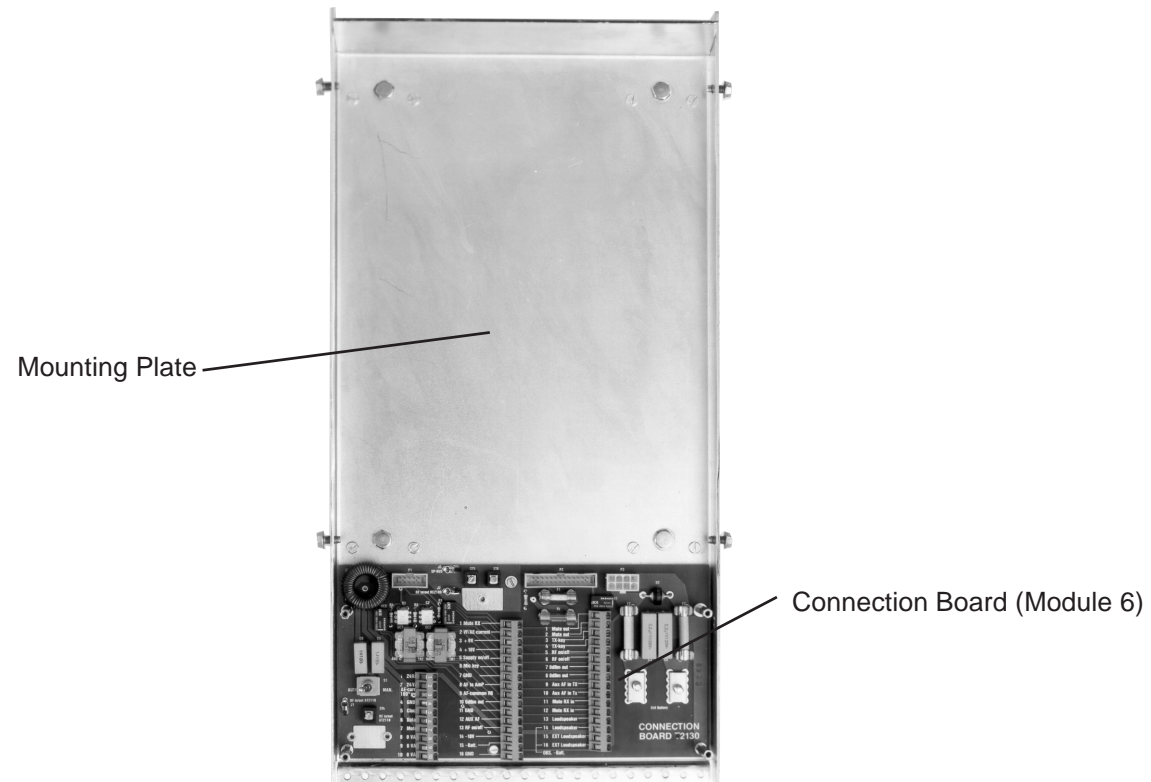
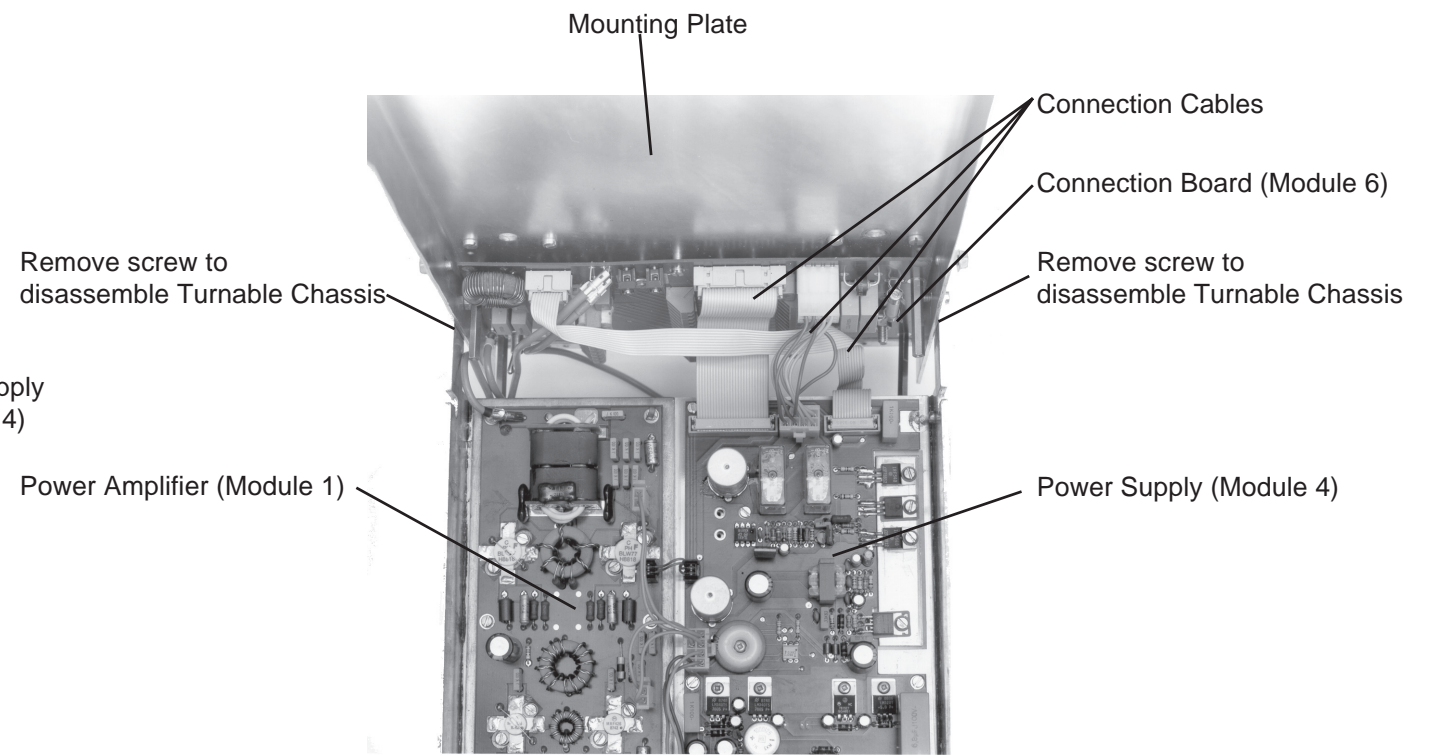
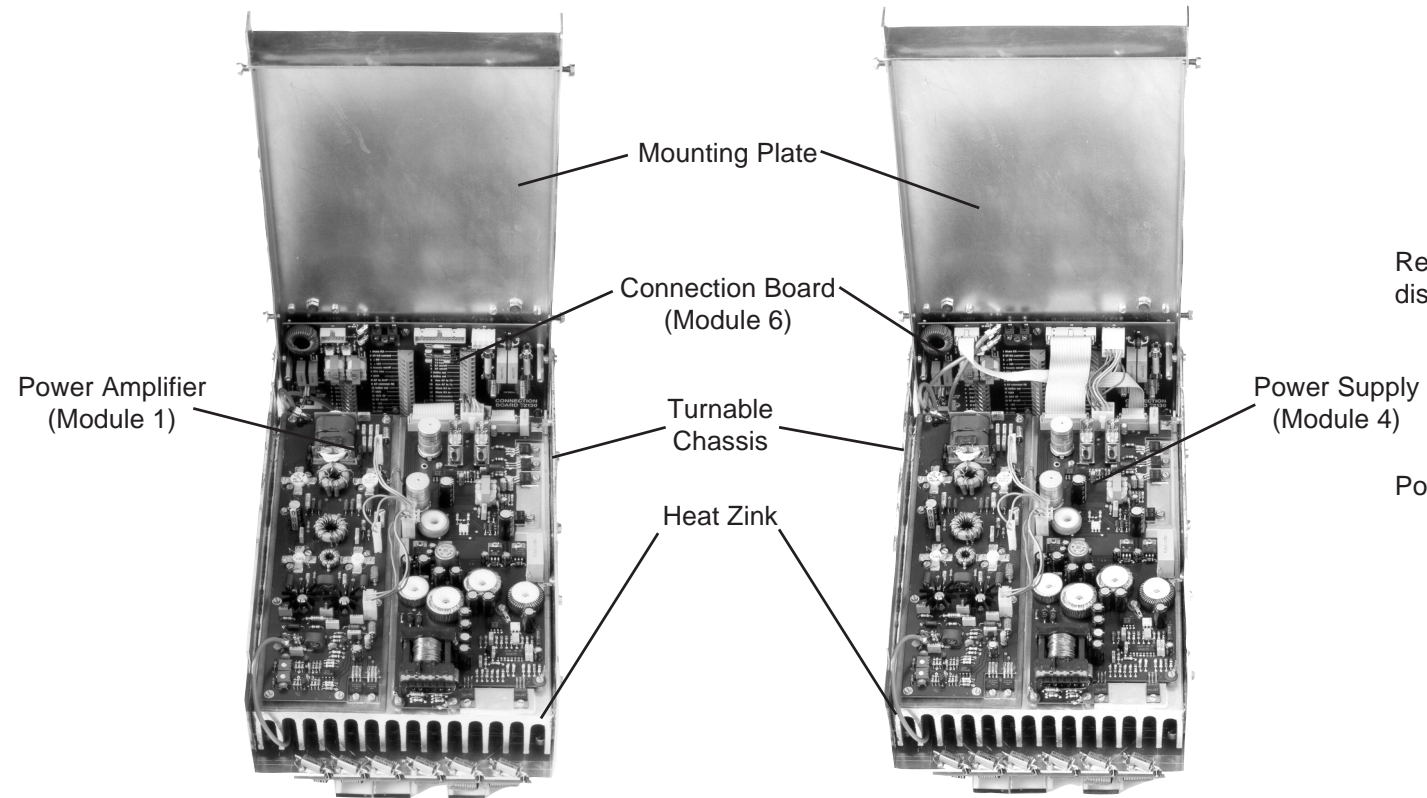

CONTENTS

5	CIRCUIT DESCRIPTION AND SCHEMATIC DIAGRAMS	
5.1	POWER AMPLIFIER (MODULE 1) PART NO. 625641	5-1
5.2	OUTPUT FILTER (MODULE 2) PART NO. 625642	5-2
5.3	TX-PROCESSOR (MODULE 3) PART NO. 625643	5-5
5.4	POWER SUPPLY I (MODULE 4) PART NO. 625644	5-7
5.6	COMPONENT LOCATION CONNECTION BOARD MODULE 6	5-28
5.9	INTERCONNECTION CABLE PLAN	5-31

5 CIRCUIT DESCRIPTION AND SCHEMATIC DIAGRAMS

5.1 POWER AMPLIFIER (MODULE 1) PART NO. 625641

The power amplifier has a gain of 50 dB \pm 3 dB.

The power input is approx. 0 dBm and the output is approx. 250W.

The power amplifier has three stages each working as a class B push-pull amplifier.

The pre-amplifier consists of two 2N3553 (Q03, Q04) transistors working in push-pull. The bias supply for the pre-driver consists of Q01, D01 and R01, R02. R01, R02 divide the 15V down to 9.6V and Q01 is a current amplifier.

Q02 is used to switch off the bias and D01 produces the basis-emitter diode of Q01 from reverse break-down when Q02 is in saturation.

The signal from the pre-driver is fed through the impedance matching transformer TR02 to the driver. The two driver transistors MRF426 (Q06, Q07) are working as push-pull class B. There is a current feed-back from TR03 through R26 to the basis of Q06, Q07. C10, R21, and C11, R22 form an input impedance matching network.

The bias supply is built around U01/1 OP.Amp.

D02 is a temperature compensating diode and is thermal connected to Q06. When Q06 gets hotter the voltage drop over D02 gets lower and thus the output of U01/1 and Q08 is lowered (Q08 is a current amplifier for U01/1). The result is that the current through Q06, Q07 is stabilized or lowered.

The bias current through Q06, Q07 is adjusted by means of the potentiometer R14.

Q05 is used to switch off the bias of Q06, Q07.

The output from Q06, Q07 is fed through the impedance matching transformer TR04 to the output stage which consists of two TH416 (Q09, Q10) transistors working in class B.

Current feed-back is taken from TR05 through R38, R39 to the basis of Q09, Q10.

C17, R31, R32, R33, and C18, R34, R35, R56 form an input impedance matching network for Q09, Q10.

The biasing network is built around U01/2 and is in principle equal to the circuit for the driver. D03 is thermal connected to Q10 and the bias is adjusted by means of the potentiometer R30.

Q11 is used to switch off the bias to Q09, Q10.

TR06 is transforming the low collector impedance of Q09, Q10 up to 50 ohm.

The power output is approx. 250W PEP.

A temperature sensor R45 sensors the temperature of one of the output transistors. The sensor is connected to the TX processor which takes care of reducing the power when the transistors get too hot.

COMPONENT LOCATION POWER AMPLIFIER MODULE 1

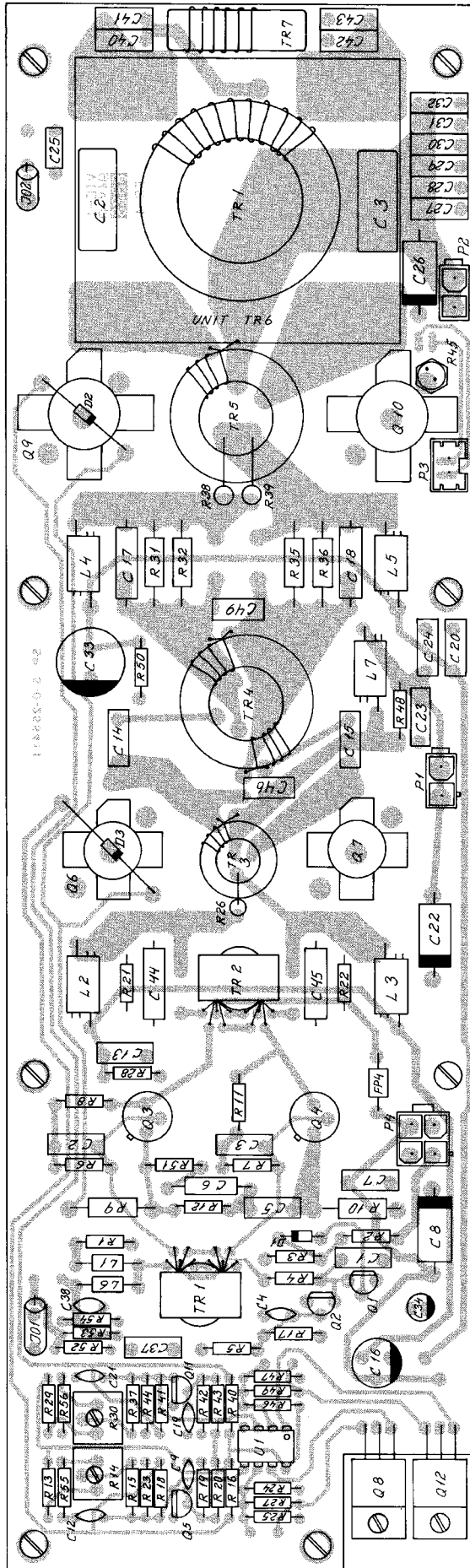
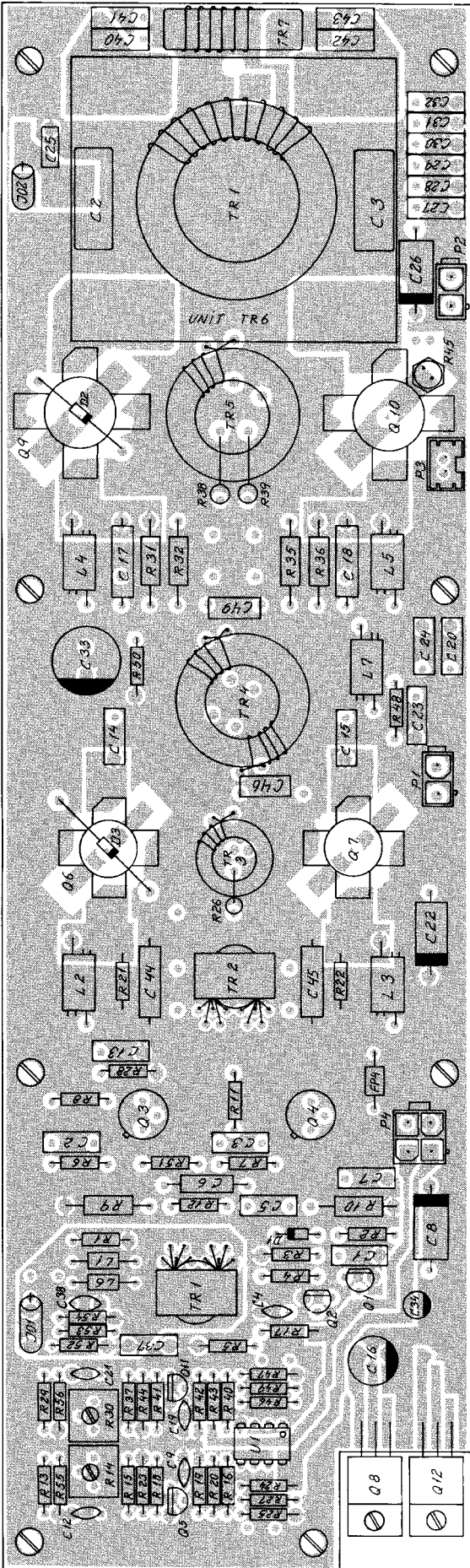

Seen from component side with upper side tracks

Seen from component side with lower side tracks

POWER AMPLIFIER MODULE 1

Power Amplifier (1)

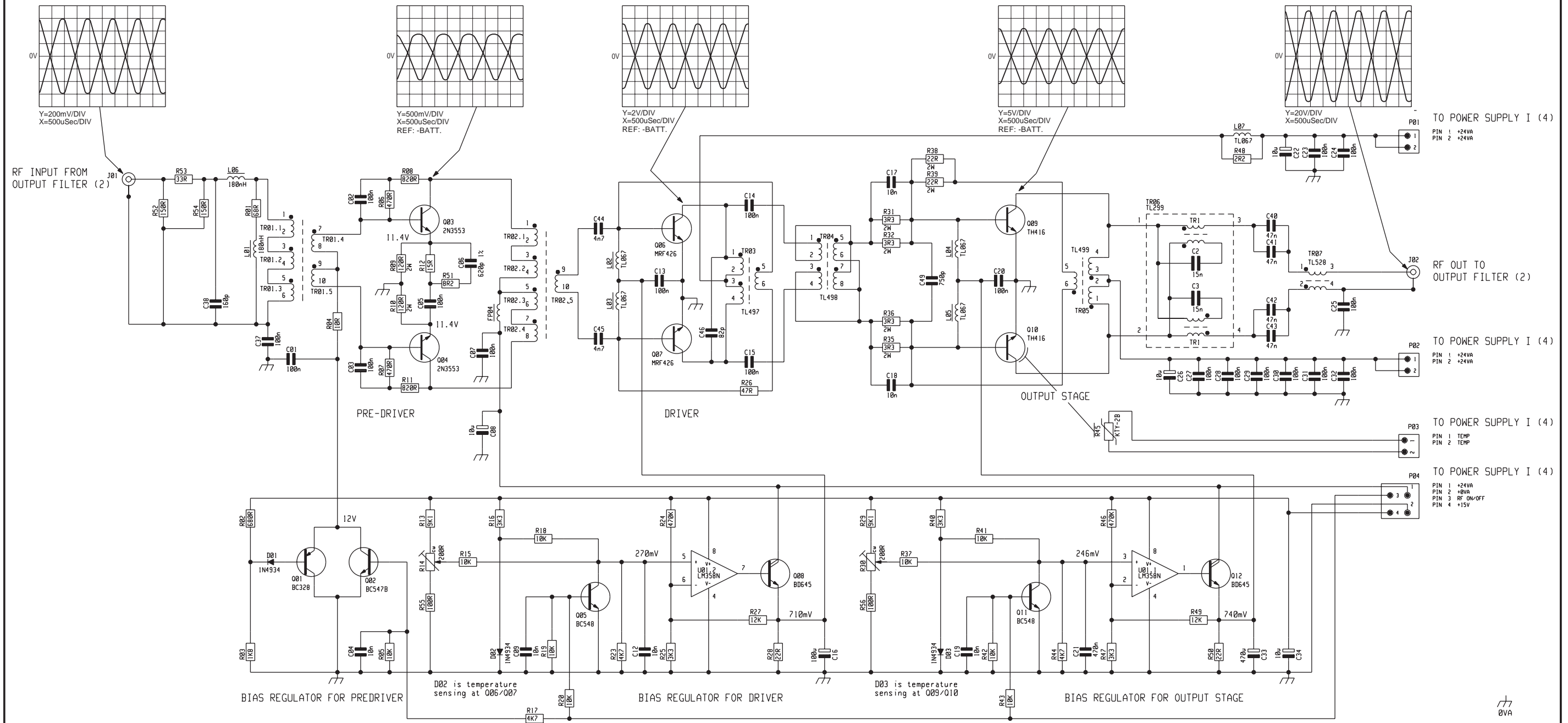

4-0-25641H

All voltages measured with transmitter in Service mode SP-29

This diagram is valid for PCB rev. 256411

5.2 OUTPUT FILTER (MODULE 2) PART NO. 625642

From the power amplifier the signal is fed to the output filters. There are six seventh order filters. These filters attunes all harmonics so that they are more than 43 dB below the fundamental frequency. The filters cover the following frequency bands:

filter No. 1 covers 1.6 - 2.5999 MHz
filter No. 2 covers 2.6 - 4.1999 MHz
filter No. 3 covers 4.2 - 6.7999 MHz
filter No. 4 covers 6.8 - 11.0999 MHz
filter No. 5 covers 11.1 - 18.0999 MHz
filter No. 6 covers 18.1 - 29.9999 MHz

Each filter is a duplex filter. The filters allow the fundamental frequency to pass through and feed the harmonics to the 100 ohm loads. This gives a good load match for the power amplifier.

From the filter the signal is fed through a directional coupler TR01. C31 is used for adjustment of the balance of the directional coupler.

The forward voltage and the reverse voltage is first rectified in a quasi effective value rectifier (VF: D09, R07, R09, and C32. VR: D10, R08, R35, and C33), then in a peak rectifier (VF: U01/3, D11, R15, R13, R11, and C36. VR: U01/4, D12, R16, R14, R12, and C37). Finally they are buffered in a unity gain amplifier (VF: U01/2, VR: U01/2). The signal from the two buffers is then fed to the TX processor.

From the directional coupler the signal is fed to RE13, RE14.

The function of the relays is:

1. RE13 and R14 not activated (receive mode).
Connects the RE2100 (RX) J03 to the antenna (AT2110) J04.
2. RE13 activated and RE14 not activated (transmit mode).
Connects the RE2100 (TX) J03 to PA input J02.
3. RE13 and R14 activated (output power setting).
Connects the RE2100 (TX) J03 to R27, R28 50 ohm dummy load. This function is used for automatic power setting. See also circuit description for TX processor module 3.

COMPONENT LOCATION OUTPUT FILTER MODULE 2

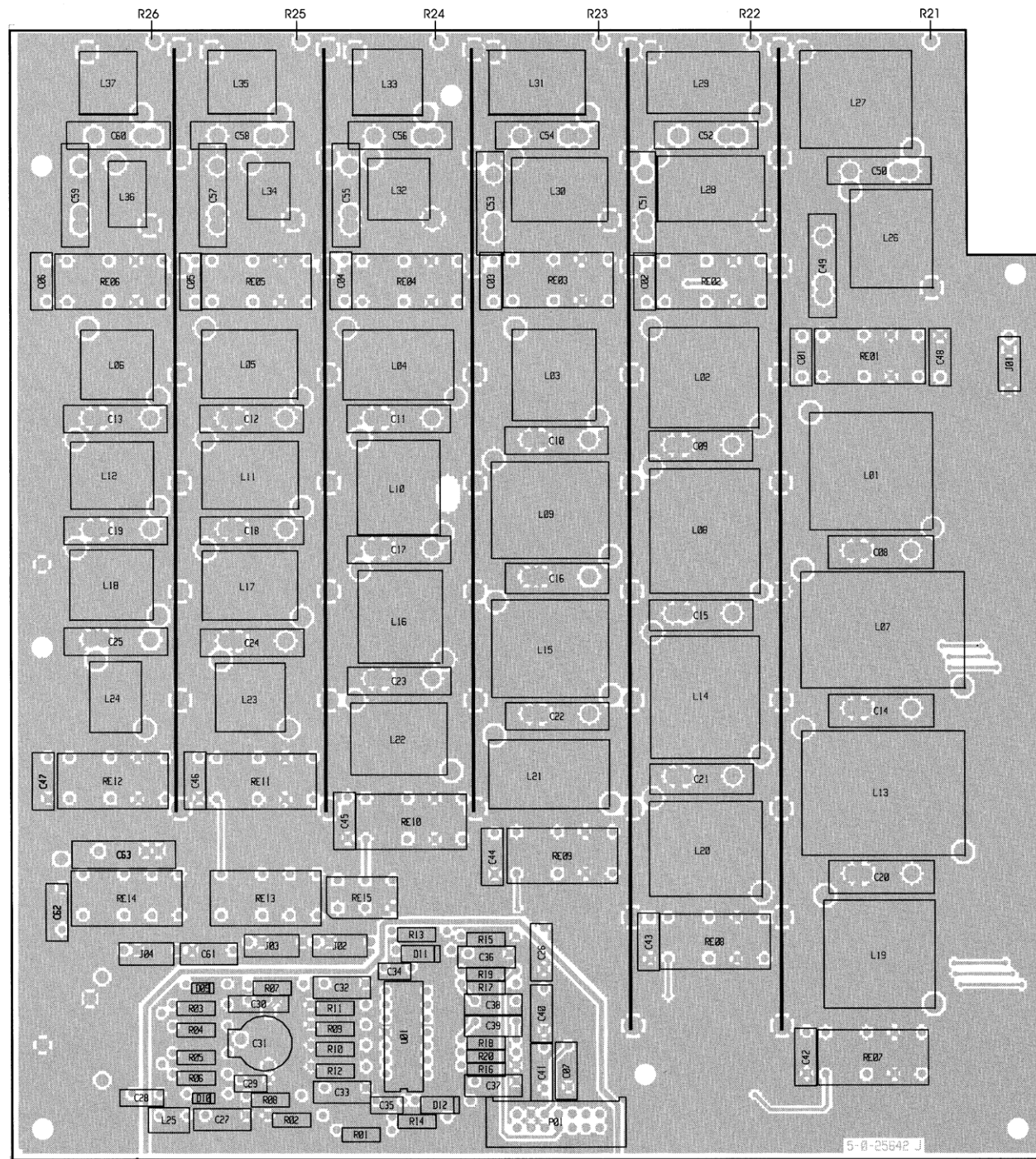

Seen from component side with upper side tracks.

PCB rev. 25642J

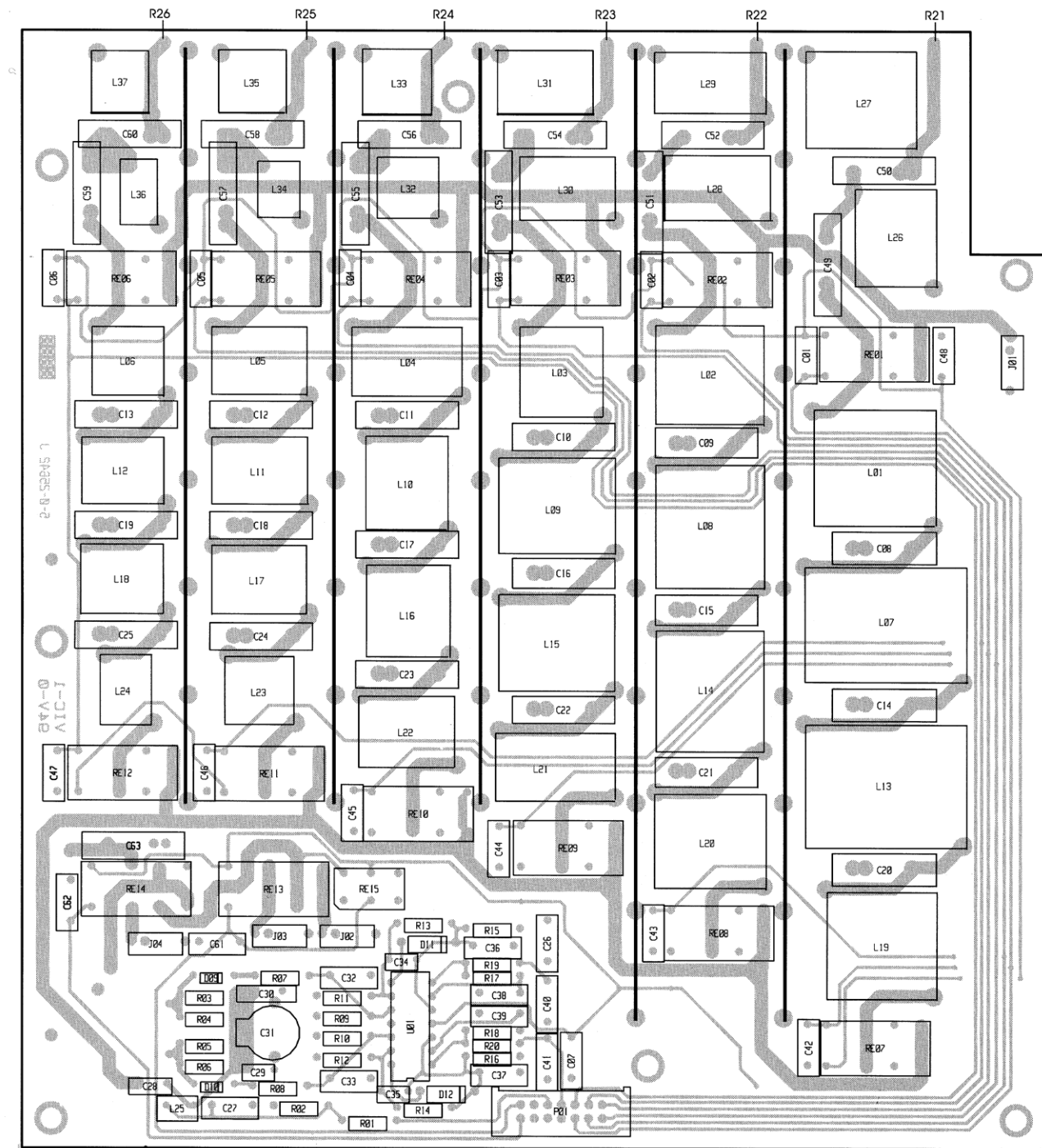

Seen from component side with lower side tracks.

OUTPUT FILTER MODULE 2

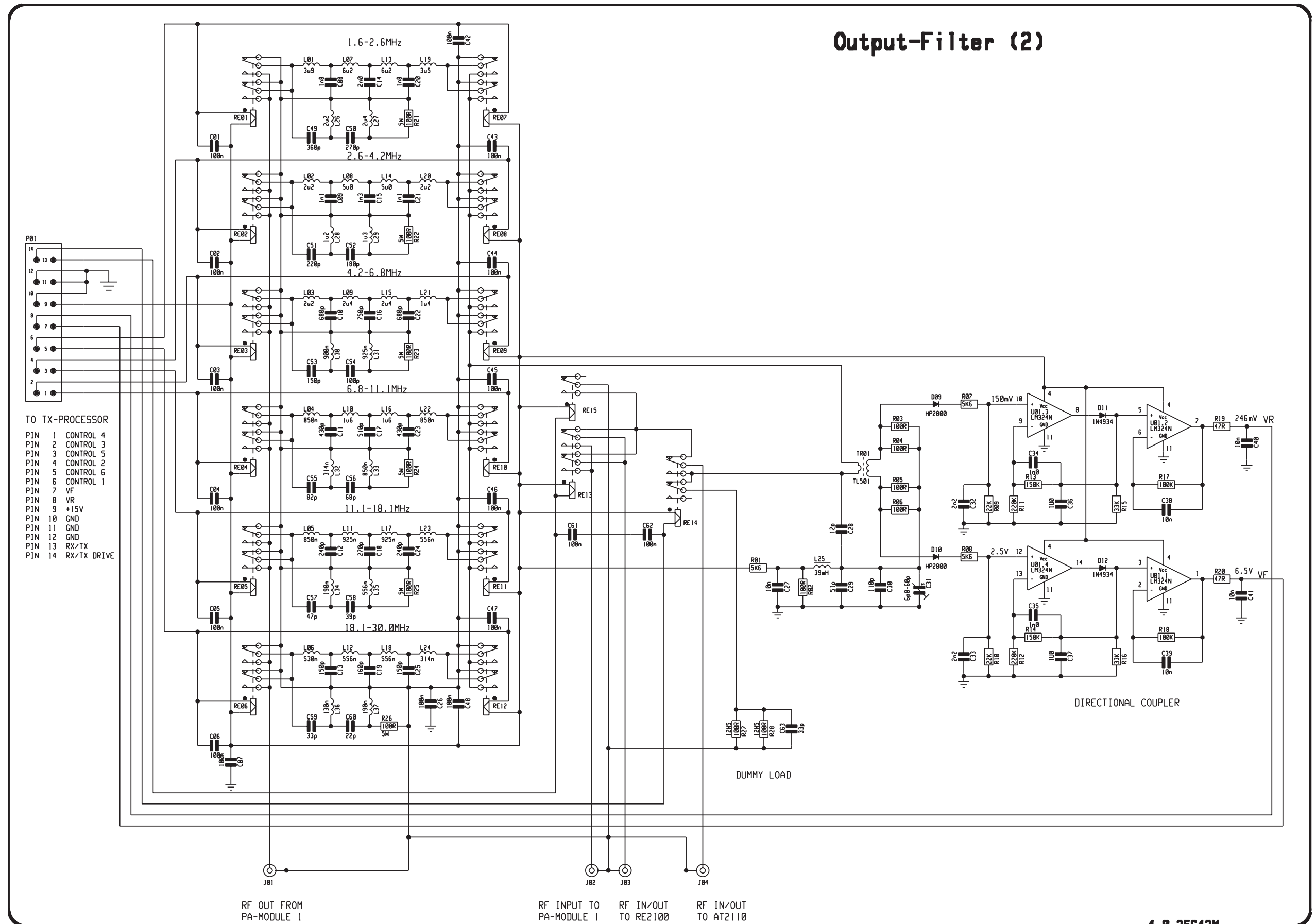

All voltages measured with transmitter in Service mode SP-29

4-0-25642M

This diagram is valid for PCB rev.25642J

5.3 TX-PROCESSOR (MODULE 3) PART NO. 625643

FUNCTIONAL DESCRIPTION

The TX-processor has the following main functions:

- communicates with the RE2100
- switches-in the correct lowpass filter
- sets drive level
- tunes the AT2110 to an acceptable SWR
- remembers the AT2110 relay combination for an acceptable found SWR
- protects the Power Amplifier (1) against high temperatures
- protects the Power Amplifier (1) against bad SWR
- ensures that the RF-output level of the PA-stage is in conjunction with the present battery voltage
- activates the AT2110 RX-relay according to selected RX-frequency

These functions are implemented partially in hardware and partially in software.

The TX-processor hardware is separated in a number of circuits, referring to the diagram:

- SUPPLY VOLTAGES
- MICROCOMPUTER
- WATCH DOG & BATTERY LOW DETECTOR
- COMMUNICATION BUS DRIVER & RECEIVER (SP-BUS)
- SERIAL DEVICE BUS DRIVER & SELECTOR
- EEPROMS
- FILTER MODULE DRIVER
- A/D CONVERTER AND SURROUNDING CIRCUITS
- TELEX OPEN AND RF ON/OFF
- AT2110 BUS DRIVER
- TUNE MOTOR CONTROL
- AE-CURRENT AND Vf CONDITIONING
- OPTION SELECTIONS (JUMPERS)

SUPPLY VOLTAGES

The board is supplied with the following voltages via P06. These voltages are galvanic isolated from the battery:

- +5A General purpose 5 Volt
- +5VB Back-up voltage. This supply is kept stable for a period after there has been a switch off on the RE2100, or the battery voltage has fallen accidentally.
- 5V Used for the SP-Bus driver
- +15V Supply for op-amps and for the output filter (module 2).
- 15V Supply for op-amps
- +18V This is only used for sensing as the +5VB is generated from this supply.
- +24V Sense. This voltage is only used for measuring. The +24V sense is proportional to the Battery Voltage.
- GND Common to the above supplies.

The following supply has a direct connection to the battery and is **NOT** galvanic isolated:

- +21V Battery voltage. Supplies the circuits related to the AT2110.
- 0VA Return for the +21V.

MICROCOMPUTER

The purpose of the microcomputer block is to run the programme properly. It consists of the following units:

- an 8 bit Hitachi microprocessor U02
- an EPROM carrying the programme U01
- chip select circuit for the EPROM P01 and U13/2
- a watch dog & battery low detector U03.

There are several options when configuring the microcomputer. The options are selectable in the jumper block area, ref. P01.

- P01 selects where the microprocessor has to find the programme.

I - Mode: Internal mode, (U02, pin 5 at +5V)
 This means that the programme must be masked and the processor is an HD6301Y type.
 The remaining jumpers P01/2, P01/3, and P01/4 have then no sense.

E - Mode: External mode, (U02, pin 5 at 0V).
 The programme must reside in an EPROM (PROM) ref. U01. The processor type can either be HD6301Y or HD6303Y.

- P01/2 sets the EPROM size
- P01/3 &
- P01/4 select in conjunction the address where the EPROM is to be seen for the microprocessor.

27C64 starts address E000 Hex:

Figure 1: P01 connections for 27C64

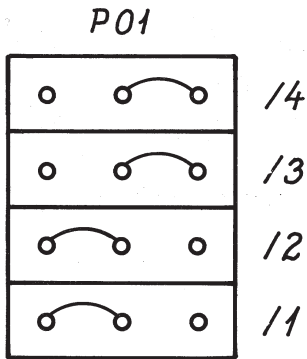

27C128 starts address C000 Hex:

Figure 2: P01 connections for 27C128

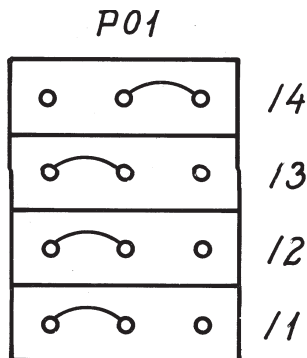

27C256 starts 8000 Hex:

Figure 3: P01 connections for 27C256.

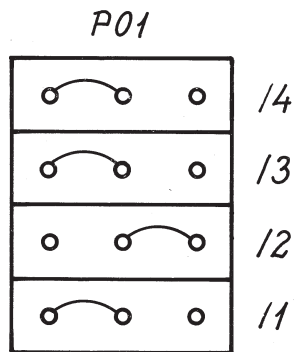

26043 1/9

WATCH DOG & BATTERY LOW DETECTOR

The MAX 690 (U03) has the following purposes:

- ensures a proper reset for the microprocessor when the +5VB is stable
- senses the +18V (PFI, pin 4), and gives an early warning when the supply is failing. The limits for the battery low detector are the following:
 - The PFO (pin 5) must be high (+5V) at 17.231 Volt or higher on the +18V.
 - The PFO must be low (0V) at 14.148 Volt or less on the +18V supply.
- Watch dog.
 During normal operation the microprocessor resets the watch dog at known locations in the programme.
 If the microprocessor stays too long in an unintentional loop, without resetting the watch dog, the watch dog will activate the reset pin on the microprocessor.
 This may happen if the microprocessor is waiting for an external event which never occurs (failure in hardware), or noise has disturbed the programme execution.

COMMUNICATION BUS DRIVER & RECEIVER (SP-BUS)

The communication to the RE2100 is time multiplexed data bus. It is implemented with one 50 ohm coax cable terminated in each end and a driver and a receiver in each connected unit. The RE2100 is the master and a number of slaves may be connected to the SP-Bus.

The driver and the receiver circuits are identical in each unit connected to the SP-Bus.

The driver output is normally in high impedance state except when transmitting on the SP-Bus.

The driver consists of two gates, U04/1 & U04/2 (74HC132), a transistor Q01 (BC558) for level shifting and two complementary output transistors Q02, Q03.

The driver is connected to the microprocessor U02, pin 13 (Port 2, bit 4, transmit data), and pin 10 (port 2, bit 1, driver enable).

The receiver consists of an op-amp, U06/1 (1458) which is configured as a Schmitt Trigger and a gate U05/1 (74HC08) for level conditioning.

The receiver is connected to the microprocessor U02, pin 12 (port 2, bit 3, receive data).

As the level on the SP-Bus approximately matches the RS232C standard, it is possible to connect an RS232C to the SP-Bus. The cable terminations (jumper P04) must be removed when the external RD232C is to transmit on the SP-Bus.

SERIAL DEVICE BUS DRIVER & SELECTOR

The serial device bus consists of:

- clock
- Data Out
- Data In
- several select lines
- special select for the A/D converter

The serial bus occupies 6 bits of port 6 on the microprocessor. Bit 0, bit 1, and bit 2 are connected to the serial device selector, bit 3 is the special select for the A/D converter, bit 6 is the clock, and bit 7 is data.

The serial device selector is a 3 to 8 line decoder 74HC237 (U07). The 3 input lines give 8 selects on the output, one selected at a time. The following codes are used:

- 0 - none is selected
- 1 - EEPROM U11
- 2 - EEPROM U12
- 3 - shift register U10, filter module driver
- 4 - shift register U14, tune motor control
- 5 - AT2110 driver
- 6 - not used
- 7 - A/D converter, reference voltage switch

The serial device selector is supplied by +5VB.

The serial device bus driver consists of 3 lines:

- clock, port 6, bit 6
- Data Out, port 6, bit 7
- Data In

In order to have a safe communication, the clock and Data Out are buffered. The buffers are 74HC08 (U08/3 and U08/4) supplied by +5VB.

The Data In line is connected direct to Port 6, bit 7. R04 ensures a definite impedance on the Data In line.

To inhibit an unknown current sink in the serial device bus when the supply is failing, the buffers are gated with PFO signal from the battery low detector (U03, pin 5).

EEPROMS

U11 and U12 EEPROMS are supplied by the back-up voltage +5VB. They are connected to the serial device bus direct to the microprocessor as the serial device bus closes down when the +18V is failing.

U11 and U12 EEPROMS remember the data for the fast retune of the AT2110.

By use of service programmes it is possible to delete these retune data.

U11 and U12 EEPROMS are from S. P. Radio initialized and programmed with certain constants related to the specific T2130, where the TX-processor is located. The constants are saved in the EEPROMS by means of service programmes.

When any of the EEPROMS are replaced both must be initialized again and the T2130 must be calibrated. Refer to the service programmes.

When the TX-processor board is replaced or is moved to another T2130, the T2130 must be calibrated again. Refer to the service programme.

FILTER MODULE DRIVER

The filter module driver activates all relays on the Output Filter (2). It consists of a serial to parallel shift register U10, 74HC595 and 8 open collector Darlington drivers located in U08 and U09 (MC1413/ULN2003).

The filter module driver is connected to the serial device bus and is supplied from the +5VA. The +15V is connected to U08 and U09 for protection purposes.

A/D CONVERTER AND SURROUNDING CIRCUITS

The A/D converter (ADC) converts the following analog signals to digital values:

- forward voltage, (Vforw)
- reverse voltage, (Vrev)
- +24V sense
- temperature in PA (converted to a voltage)

The ADC (U17, ADC0834) is an 8 bit converter and a 4 channel multiplexer (MUX). Data in and out are serial.

The ADC is connected to the serial device bus and to a reference voltage, +5.00V to the Vref input (pin 9). It is possible to switch the Vforw to the Vref input (pin 9) on the ADC and to make a ratiometric measuring with Vforw and Vref as inputs giving the parameter RHO direct.

Figure 4: Measuring Vforward, +24V Sense and Temperature.

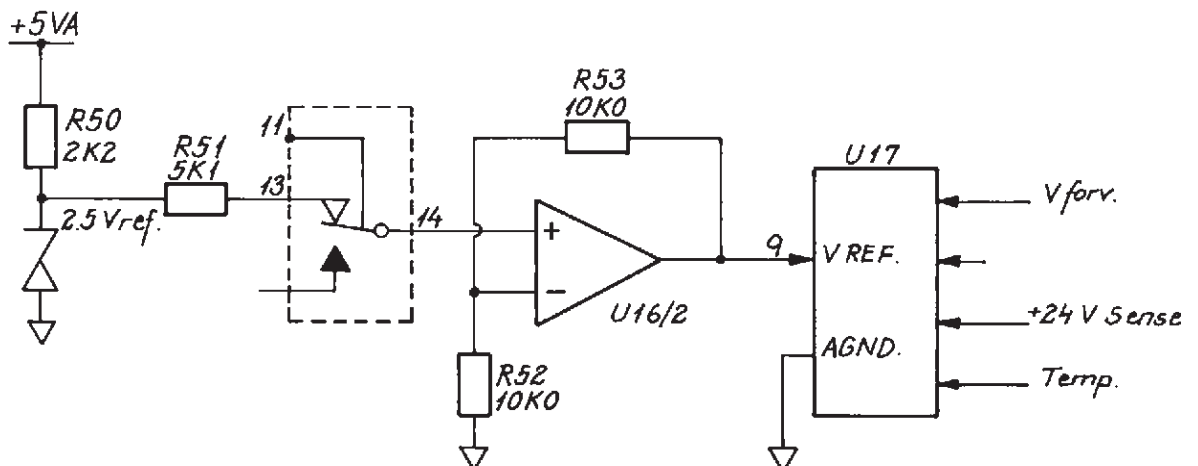

26043 2/9

When measuring a voltage, the Vref (pin 9) is at +5.0 Volt. The reference diode D14 (LM385) gives +2.5 Volt. The analog switch U15/3 (MC14053) is controlled by the serial device selector and connects the 2.5 Volt reference to the non-inverting input of the op-amp. U16/2. The op-amp. has a gain of 2, giving the 5.0 Volt reference to the ADC, pin 9.

-Vforw (P04, pin 7) is connected to channel 0 of the MUX in the ADC via a divider, R56, R55, R54.

-Vrev (P04, pin 8) is connected to channel 1 of the MUX in the ADC via a divider, R65, R64.

-24V sense (P06, pin 4) is connected to channel 3 of the MUX in the ADC via a divider, R63, R62.

-Temperature. The temperature sensor R25 (KTY11-2B) is placed near the output transistors in the Power Amplifier (1) and is connected to the TX-processor in P06, pin 13 and pin 14.

Figure 5: Temperature Sensor connections.

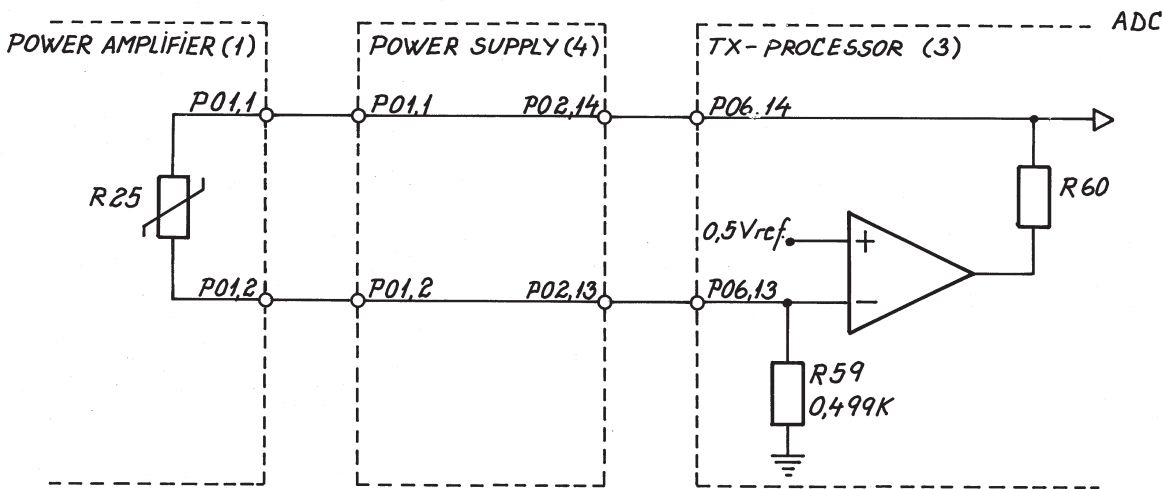

26043 3/9

The sensor is a nonlinear resistant element having 2.000 Kohm at 1 mA and 25oC. The op-amp. U16/ 1 is a voltage-to-current converter. The input voltage is the 2.5 Volt reference divided by the resistors R57 and R58, giving 0.500 Volt at the noninverting input of the op-amp. The resistor from the inverting input to ground is 449 ohm and gives a constant current flow (1 mA) in the sensor connected from the output to the inverting input of the op-amp.

R60 and C41 inhibits the op-amp. from oscillating.

Figure 6: Measuring RHO

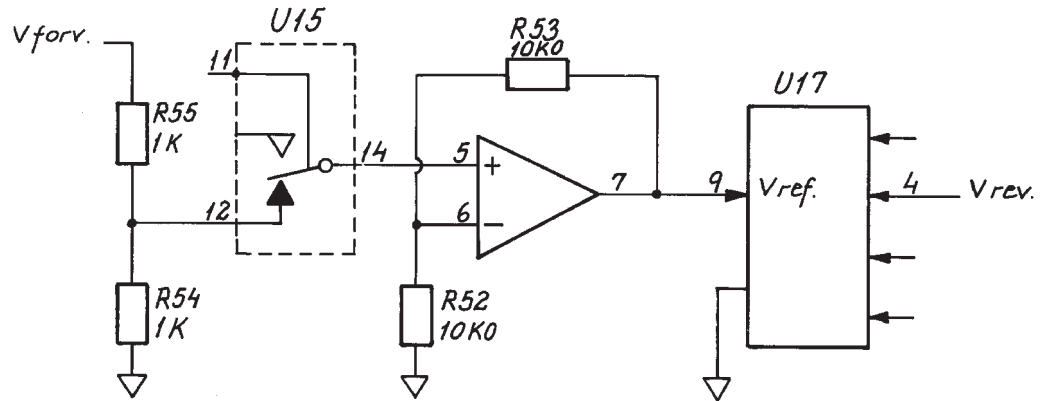

26043 4/9

When measuring RHO the Vforward is connected to reference input of the ADC (U17, pin 9). Vreverse is connected to pin 4. The result of the ratiometric measuring is the parameter RHO, defined by Vreverse divided by Vforward. $RHO = Vreverse/Vforward$.

TELEX OPEN AND RF ON/OFF

The transistor Q10 is the telex open function and Q11 is the RF on/off function. Both are controlled direct from the microprocessor (port 6, bit 4 and bit 5).

The RF on/off controls the bias for the power transistors by use of the transistors Q02, Q05 and Q11 in the power amplifier.

Figure 7: RF and Telex Control

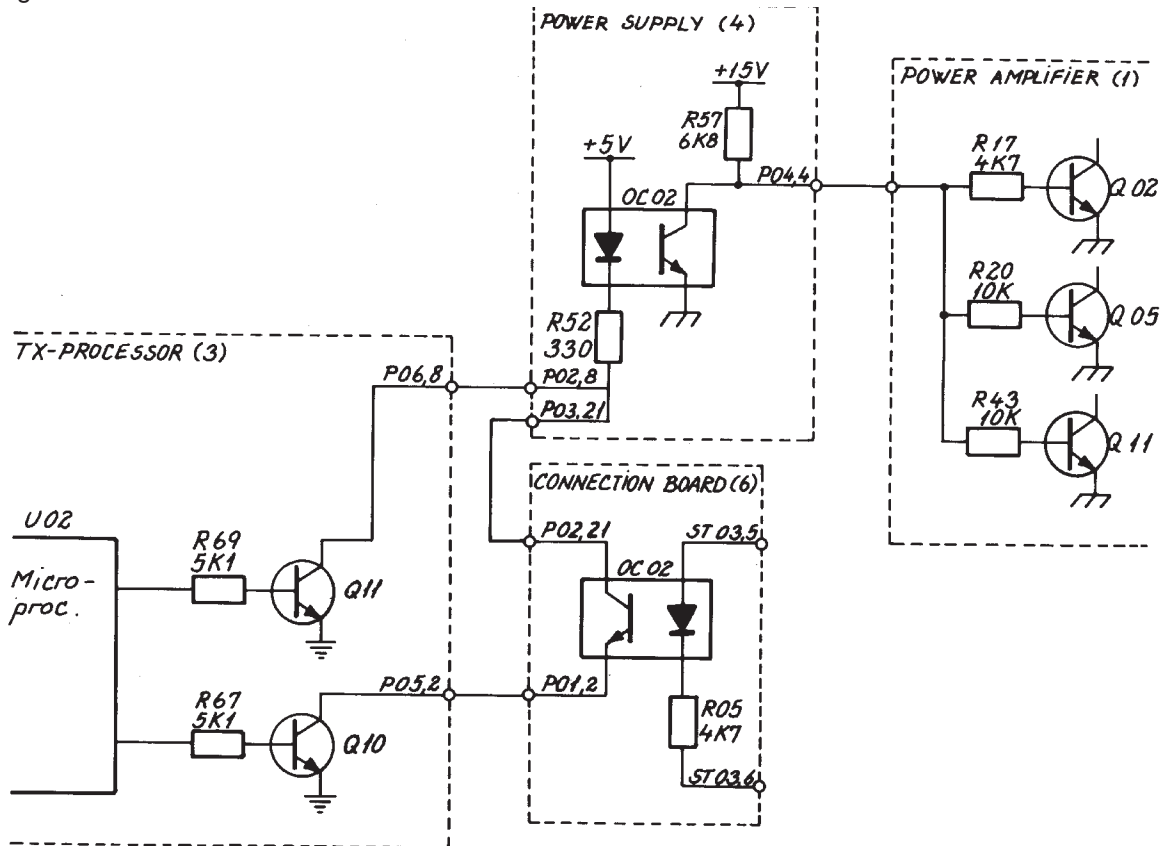

26043A 5/9

RF off and telex closed: Q10 is off and Q11 is off. This means that the transistors Q02, Q05, Q11 in power amplifier are at saturation state by a current flow from +15V through R57 in the Power Supply Unit (4).

RF on: (During tune and „key“ from the handset). Q10 is off and Q11 is on. The transistors Q02, Q05, Q11 in the power amplifier are at off state.

Telex open („key“ from the telex equipment): Q10 is on and Q11 is off. This allows the optocoupler OC02 in the Connection and Interface Board (6) to control the RF on/off function to the power amplifier.

AT2110 BUS DRIVER

The serial communication to the AT2110 consists of two identical driver stages. One driving the clock and one driving the data of the serial device bus.

Each driver stage consists of a gate U13/3 & U13/1 (74HC10), an open collector Darlington driver U09/6 & U09/7 (MC1413/ULN2003) an optocoupler and an output transistor.

The gates perform the select of the driver. The optocouplers insulate between the ground and the battery. The output transistors have their collector resistors placed on the Connection and Interface Board (3) in the AT2110.

When the AT2110 driver is not selected, the output of the gates is high (+5V) which gives light in the LED of the optocoupler so that the output transistors are in the saturation state.

Figure 8: Clock and Data to AT2110.

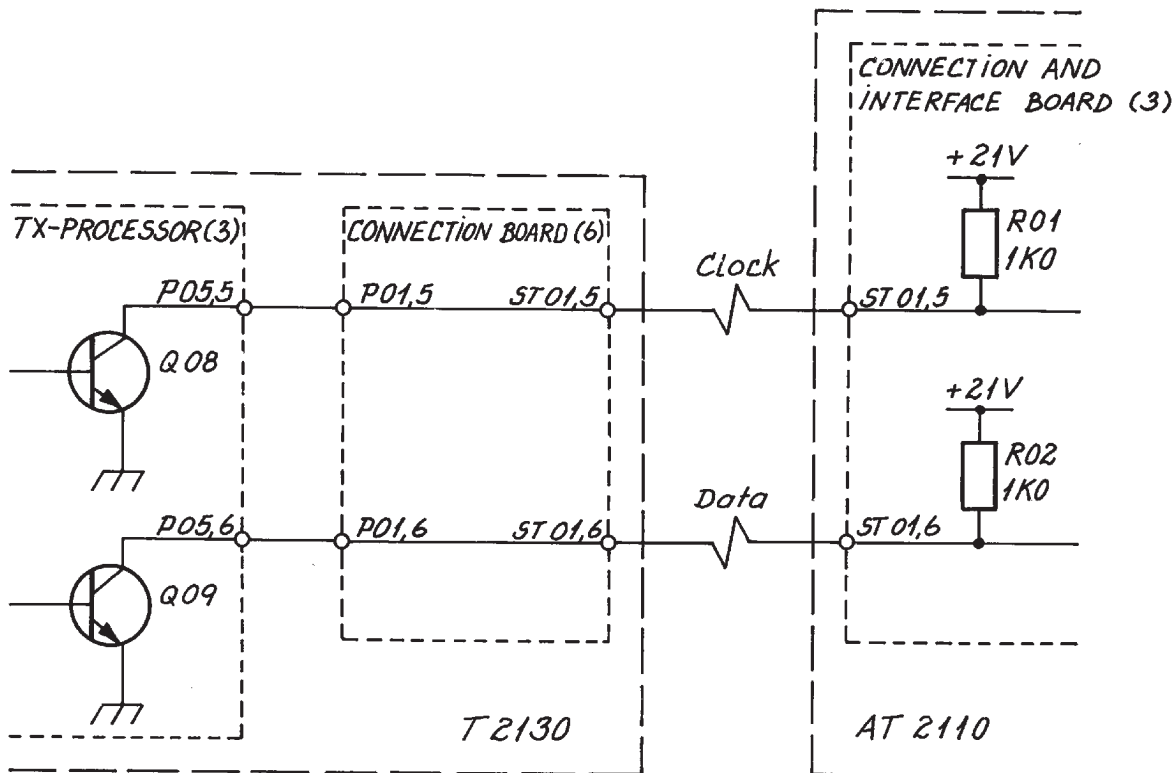

26043 6/9

The clock and data lines between the T2130 and AT2110 are then held at a very low impedance which reduces the possibility for noise introducing unintentional clock and data pulses.

TUNE MOTOR CONTROL

The main functions of this circuit are to control the motor MO1 in the AT2110 at two speeds, high and low, and detect when the variable capacitor has rotated one half turn.

The speed of the motor is selected from the microprocessor via the serial device bus and the shift register U14 (74HC595).

Two identical circuits are connected to two outputs of U14.

QA, pin 15 controls the low speed as the D07 zener diode is a 9.1 Volt type.

QB, pin 1 controls the high speed as the D08 zener diode is an 18 Volt type.

The selected zener voltage is buffered by the output transistors Q05 and Q06.

When the motor is running as it does when the power is turned on (high speed) or when tuning the AT2110 (high or low speed), a current flows in the emitting light diode in the optocoupler OC01 on the Main Board (1) in the AT2110. R05 and U10/2 on the Connection and Interface Board (2) and R25 on the Main Board (1) in the AT2110 ensure this. The detector in the optocoupler OC01 and Q01 on the Main Board (1) are both in saturation state caused by the light from the LED in the OC01.

The transistor Q07 on the TX-processor (3) is on (controlled by the microprocessor). This ensures a current flow in R41 on the TX-processor (3) and in Q01 (and the detector in OC01) on the Main Board (1) in the AT2110.

The collector of the Q01 on the main board in the AT2110 is sensed by the divider R40 and R39 and the Schmitt Trigger U04/4 (74HC132) which is connected to the microprocessor, port 5, bit 7, (U02, pin 24).

The light is broken in the open type optocoupler OC01 on the Main Board (1) when the variable capacitor C01 in AT2110 has maximum capacity and when it has minimum capacity (every 180°).

When the light is broken in the optocoupler OC01, the current flow stops in the detector in OC01 and Q01 on the Main Board (1) in AT2110. This gives a level shift which is detected by Schmitt Trigger U04/4 and the microprocessor is informed. The microprocessor turns off the supply voltage to the motor MO1 and the rotation stops.

When the motor MO1 must run at low speed (the AT2110 is tuning) it is always started at high speed and reduced to low speed when the rotation has begun. The high speed time period is the time it takes to rotate the variable capacitor C01 so far that the light from the light emitter diode in OC01 turns on the detector in OC01 and the transistor Q01 on the Main Board (1). This is detected and the microprocessor will immediately change to low speed.

Figure 9: Motor Control Circuit

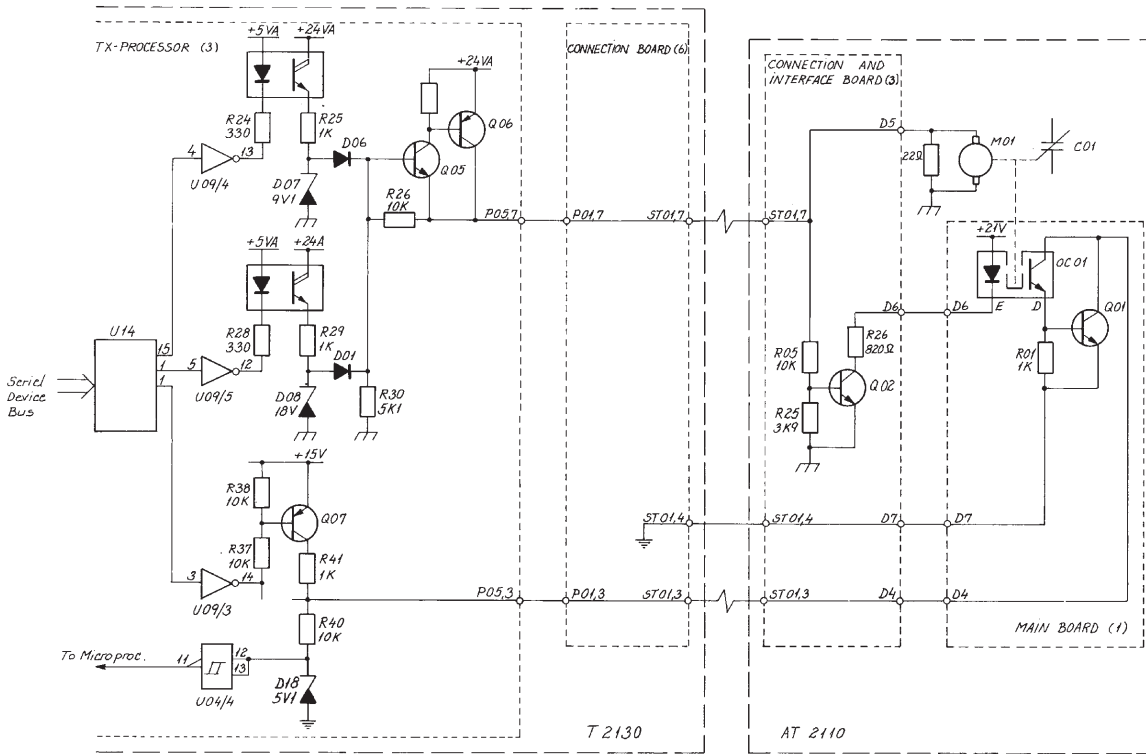

26043B 7/9

AE CURRENT AND Vf CONDITIONING

The signal „AE-current“ and the signal „180° pulse“ share one wire between the AT2110 and the T2130. This means that the AE-current cannot be transferred to the bar-graph in the RE2100 when the AT2110 is tuning. The Vforward is transferred to the bar-graph when the AT2110 is tuning. When the T2130 is keyed (the tuning has finished) the AE-current is displayed on the bar-graph. If the jumper 5 is inserted in the P02 and the T2130 is keyed the Vforward is displayed on the bar-graph.

Figure 10: AE current/Vforward - bar-graph.

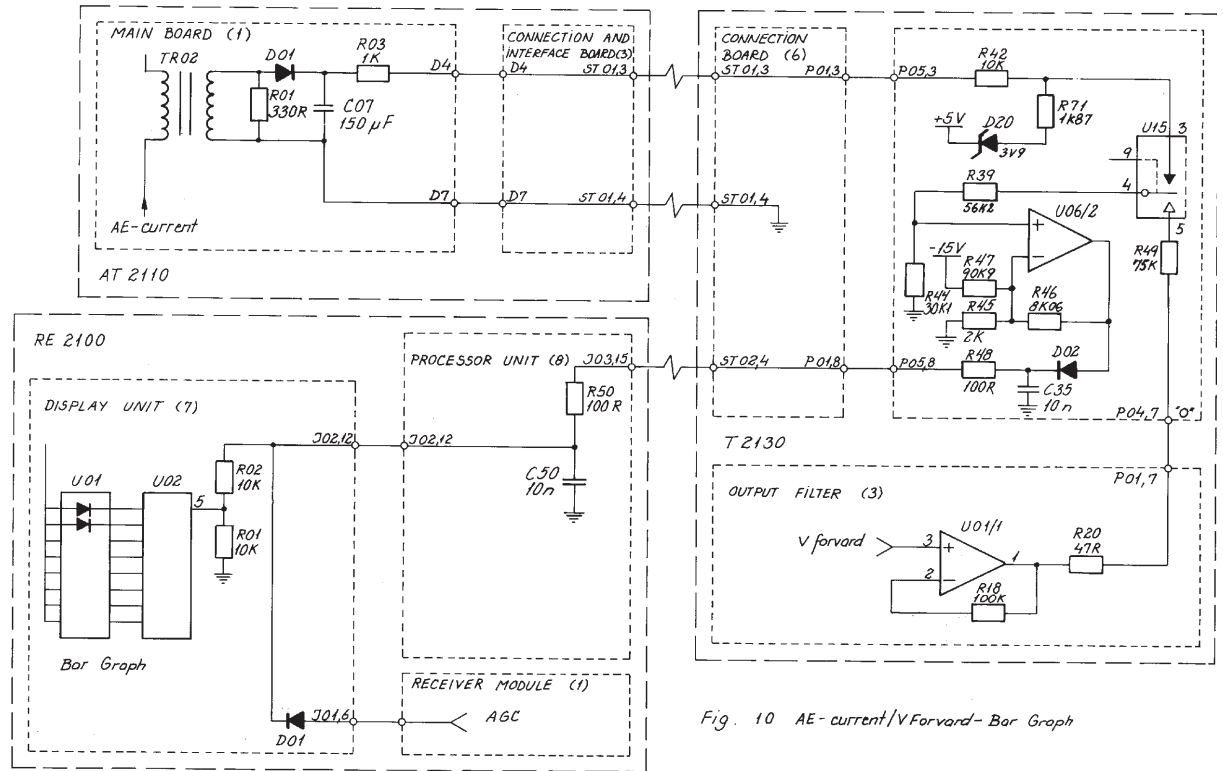

Fig. 10 AE-current/VForward- Bar Graph

26043C 8/9

The analog switch U15/2 which is controlled by the microprocessor via the serial device bus and the shift register U14 and the driver U09/3 switches between the AE-current and the Vforward.
 AE-current comes in from the AT2110 to the TX-processor in P05, pin 3 and is divided by the resistors R42 and R44. When the level exceeds approx. 5.7 Volt the diode D20 opens and the dividing ratio is changed. This ensures that the level corresponds to the logarithmic scale on the RE2100.
 Vforward comes in from the Output Filter (3) at P04, pin 7 and is divided by the resistors R49 and R44. The selected signal is buffered by U06/2. The output is fed to P05, pin 8 and runs to the processor unit (8) in the RE2100 where it is conditioned and lead to the display unit (7) in the RE2100 where it is mixed with the AGC-signal from the Receiver (1). Please refer to the circuit description for the RE2100 modules.

OPTION SELECTIONS (JUMPERS)
ALL SOFTWARE VERSIONS HIGHER THAN OR EQUAL TO C10830

Figure 11: Jumper Identifications

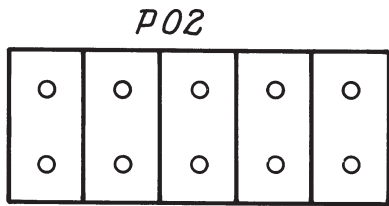

Jumper: 1 2 3 4 5

26043 9/9

Jumper	Inserted	Out
1	The communication on the SP-bus is without parity bit.	Normal communication with RE2100.
2	New aerial coupler AT2110 No. 430454 or higher.	Old aerial coupler AT2110 up to No. 430453.
3	Do not insert. For future use.	Normal operation.
4	The „Signal Straight through“ relay set-up in the AT2110 is NOT tested when tuning the AT2110.	Normal operation.
5	This tells the microprocessor that a T2110 does not exist in the system. All communication to the AT2110 is disabled.	Normal operation. The AT2112 is in the system.

OPTION SELECTIONS (JUMPERS) ALL SOFTWARE VERSIONS UPTO INCL. C1083N

Figure 11: Jumper Identifications

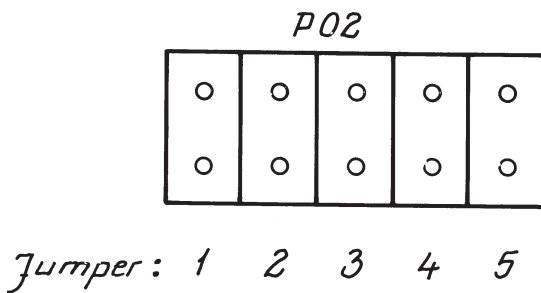

26043 9/9

Jumper	Inserted	Out
1	The communication on the SP-bus is without parity bit.	Normal communication with RE2100.
2	Watch dog reset disabled. of the watch dog.	Normal communication
3	Do not insert. For future use.	Normal operation.
4	The „Signal Straight through“ relay set-up in the AT2110 is NOT tested when tuning the AT2110.	Normal operation.
5	This tells the microprocessor that a T2110 does not exist in the system. All communication to the AT2110 is disabled.	Normal operation. The AT2112 is in the system.

COMPONENT LOCATION TX-PROCESSOR MODULE 3

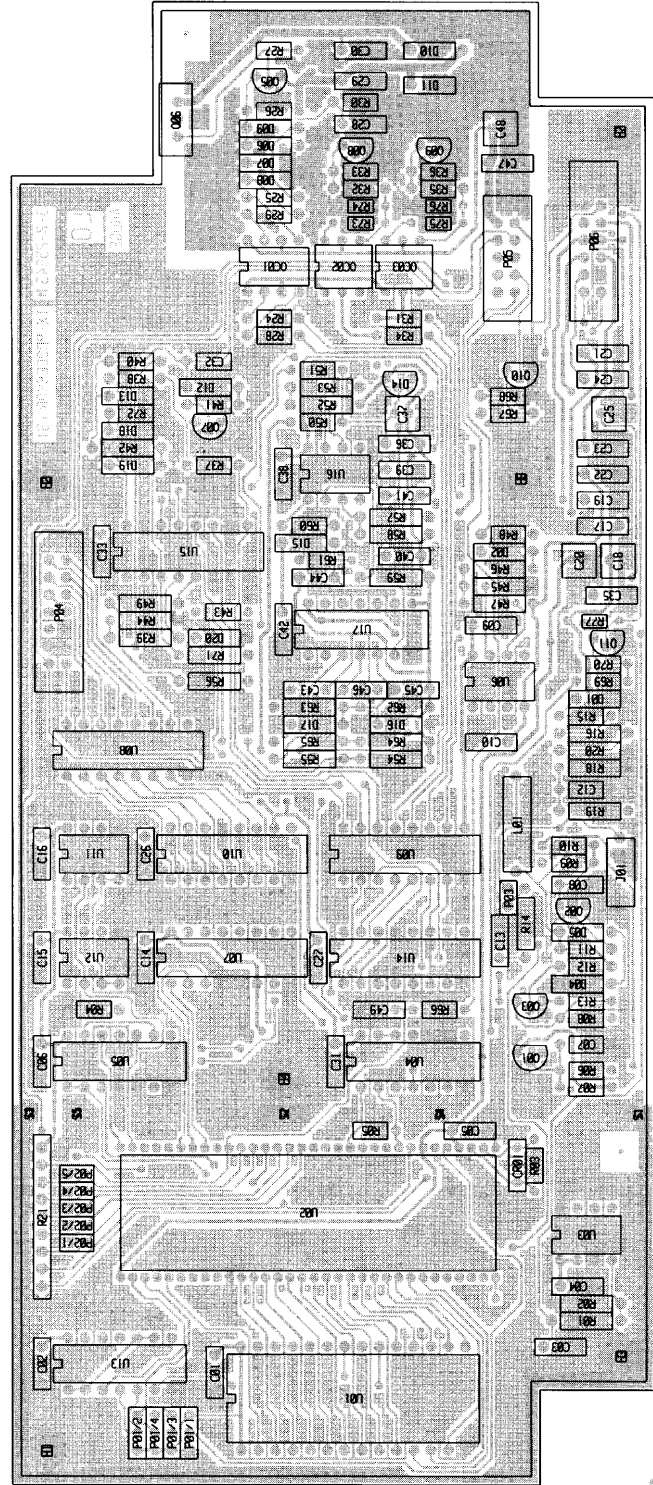
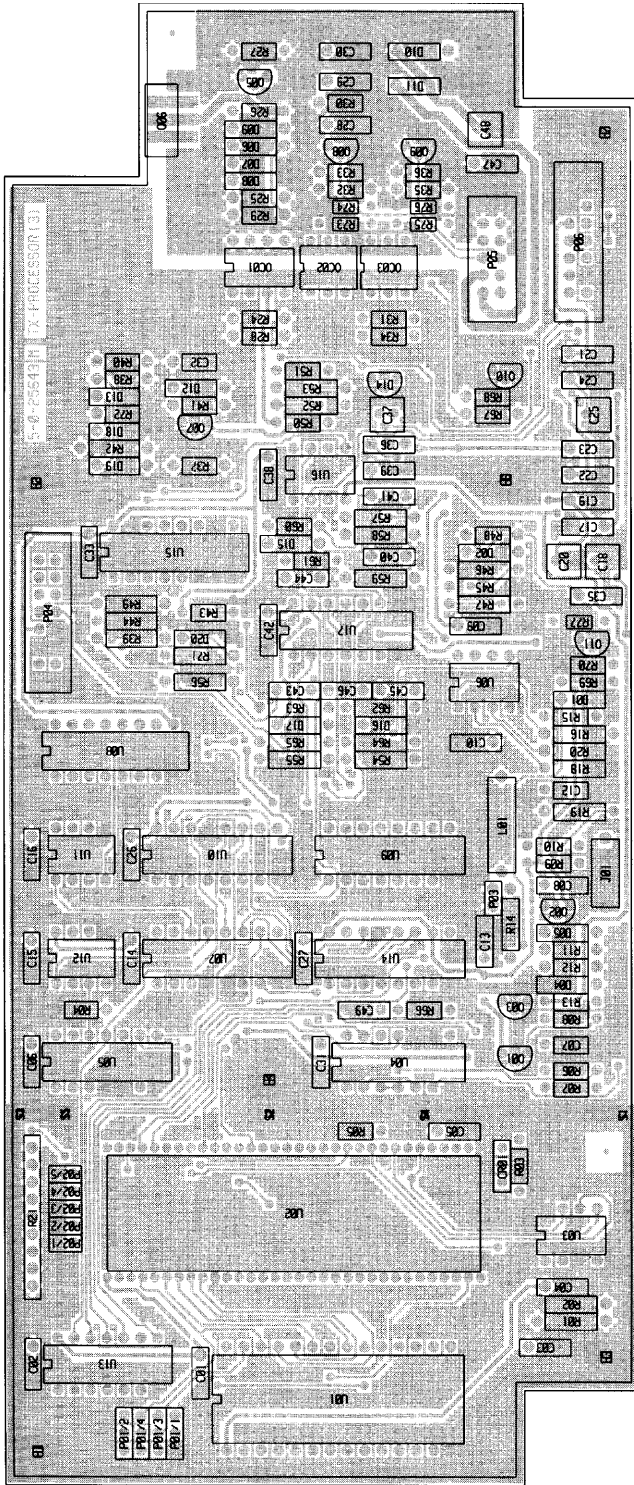

View from component side with upper side tracks.

View from component side with lower side tracks.

PCB rev. 25643M

TX-PROCESSOR MODULE 3

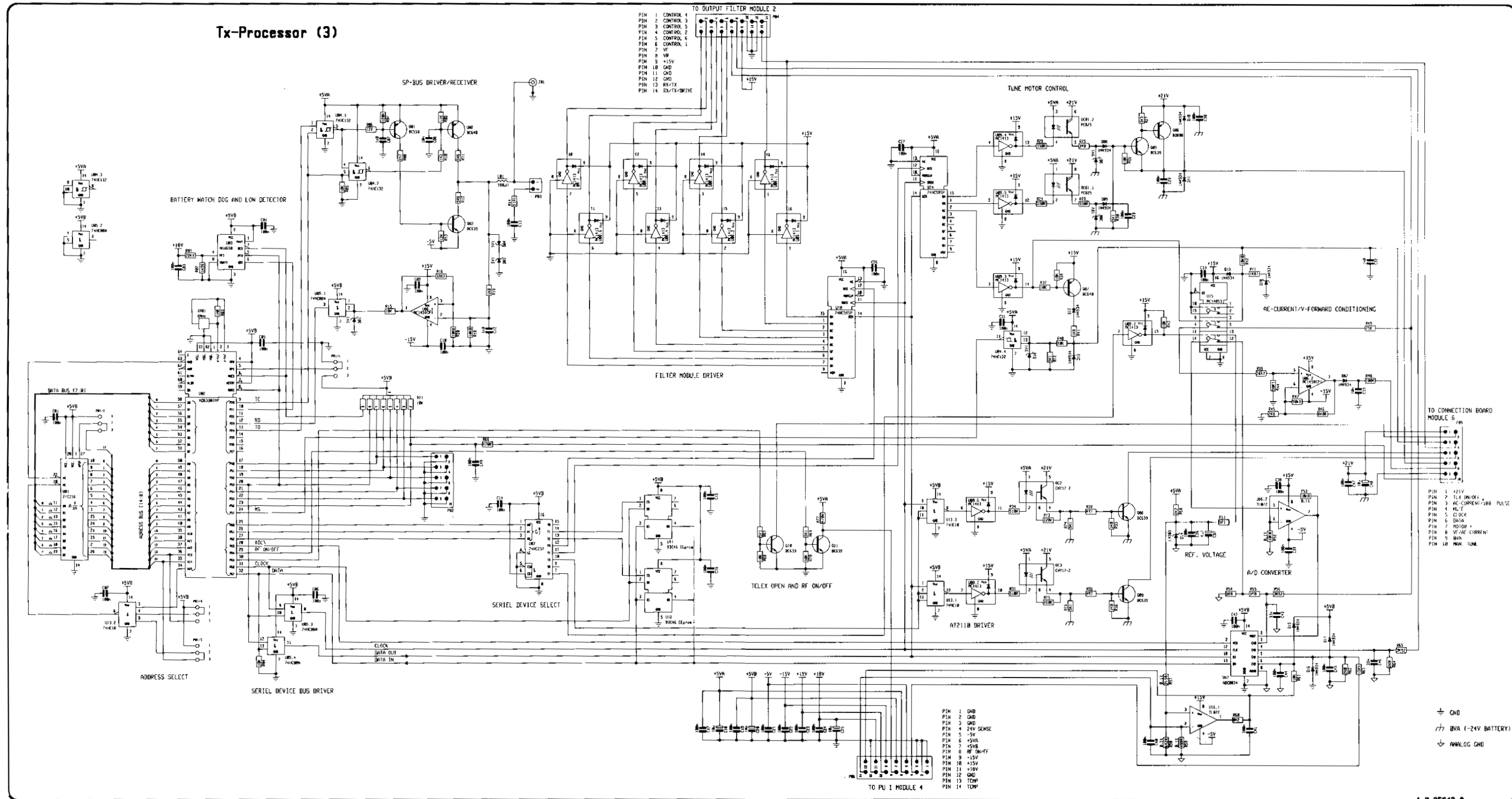

This diagram is valid for PCB rev. 25643M

5.4 POWER SUPPLY I (MODULE 4) PART NO. 625644

This unit contains power supplies for RE2100, AT2110, and T2130. It also contains the audio amplifier for RE2100.

SWITCH MODE POWER SUPPLY

The power supply is a forward switch mode converter. It converts the 24V DC battery voltage to $\pm 18V$ DC and +9V DC. $\pm 18V$ DC and 9V DC are fed to RE2100.

The output voltage of the +18V DC output is sensed and compared with a reference voltage by an operational amplifier resulting in an error voltage. The current running in the output transistors is sensed over a resistor. The error voltage from the operational amplifier is then compared with the current signal by a comparator.

The oscillator produces a synchronization pulse. This pulse is triggering two flip-flops. One flip-flop is used to alter between the two output MOS transistors working as a push-pull transformer coupled output stage. The other flip-flop turns on the selected output transistors. This flip-flop is turned off by the comparator. So every time the current has reached the level set by the error voltage, the output transistors are turned off. If the output voltage falls, the output supply current is allowed to raise, the pulse width is enlarged, and the output voltage is then reestablished. The regulator is then working in a current mode instead of the usual voltage mode. This is of great advantage for the stability of the control loop, (first order instead of second order loop).

Current limiting is easily done by limiting the error voltage to a fixed maximum voltage. The current is limited to approx. 3.5A

The pulse width regulated voltages from the secondaries of the transformer are then rectified and smoothed by inductors and capacitors.

The sum of the three currents are sensed by a resistor. If this voltage is outside $\pm 0.35V$ DC approx. (equal to $\pm 1.5V$ DC approx.), the converter is stopped and goes into soft start. This is to protect the rectifier diode against output short-circuit.

All the necessary amplifiers, flip-flops, etc. are contained in the IC U01.

L01, C02-C05 are the input filter.

The 12V DC supply voltage for U01 is made by R01, D02, C06, and C07. If the supply voltage is lower than approx. 7.5V DC the internal under voltage lock-out is in action.

R02 and C08 determine the oscillator frequency to approx. 50 kHz.

The non-inverting input of the error amplifier is connected to the voltage 12V DC by R03. The inverting input is connected to the reference voltage by R05.

D23 and OC01 are the feed-back loop of the error amplifier. R48, C46, and R45, C53 are frequency compensation in the feed-back loop to avoid self oscillations.

R08, R09, and C11 are the feed-back loop of the error amplifier.

The output MOS transistor current is sensed by R16-R20, 5 resistors in parallel to minimize the induction. The current signal is then led to current sense amplifier input, pin 4. The R14 and C12 make a lowpass filter to remove noise. The emitter of Q01 follows the ramp voltages on the oscillator capacitor C08. R07 adds some of this ramp signal to the current signal. This is necessary to avoid sub-harmonic oscillations when the duty-cycle is higher than 50 per cent.

The voltage on pin 1 determines the clamp voltage for the error voltage. This voltage is determined by R04 and R06. The capacitor C10 is the soft start capacitor, making the duty-cycle and the output voltages raise slowly.

The two pulse width modulated outputs are led to the two output MOS transistors by R10 and R11. These two resistors slow down the rise times of the MOS transistors to prevent spurious oscillations. R12 and R13 secure that the transistors always stay off when the IC U01 is off.

R27, C14, R29, C15, R28, and C16 are snappers, reducing oscillation due to stray capacitors and stray inductions in the transformer.

D06 to D11, L02 to L04, and C17 to C22 are the three output rectifiers and filters.

R30 and R31 limit the voltage in case of no load conditions.

The switch mode power supply is followed by regulators for $\pm 15V$ and $\pm 5V$. These voltages are used to supply the modules in T2130. The +5VA is used to back-up the microprocessor, when switching off. D12 prevents current to flow from C23 to other circuits than U03.

24VA REGULATOR

The regulator is regulating the battery supply so it is limited to 28V. It also protects the AF-amplifier and the power amplifier from transients on the battery supply.

The output voltage is sensed by the voltage divider R44, R43 and fed back to the shunt regulator D18. If the output voltage rises above 28V, D18 starts to conduct and the gate of Q06 and Q07 goes lower. When the gate goes lower the drain to source resistance rises and the output voltage is kept on 28V. If the output is less than 28V, D18 is not conducting and the gate is high (+50V), thus keeping the drain to source resistance low (voltage drop D-S = 0.5V).

D17 is protecting D18 from over voltage.

D21 is protecting the gate/source from break-down. The on/off switching is done with RE01 and RE02, controlled from on/off switch in RE2100.

21V REGULATOR

The 21V regulator is stabilizing the supply for the aerial coupler. The regulator is a low drop regulator. D24 is reference voltage for the regulator. R60 and R61 determine the output voltage.

AF AMPLIFIER

The AF amplifier is built-up around U07.

The amplifier is supplied from the battery via the 28V regulator. In the input there is a transformer to obtain insulation between -battery and chassis. It also suppresses common mode noise from the multicable to RE2100.

The input impedance is 600 ohm.

R39 and R38 are setting the voltage gain to 37 dB.

At the output, R40, C36, FP01, FP02, and C37 prevent U07 from oscillating.

When loaded with 8 ohm, output power will be 5 Watt, when loaded with 4 ohm, output power will be 10 Watt

COMPONENT LOCATION POWER SUPPLY MODULE 4

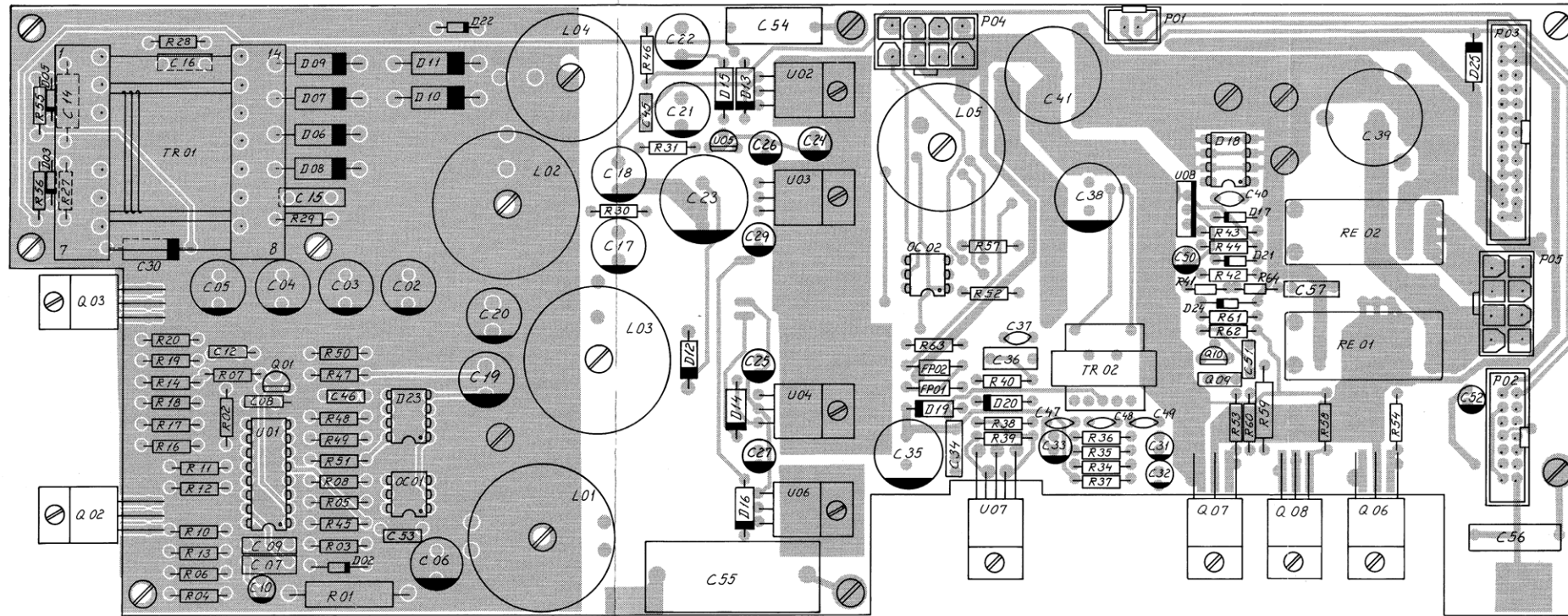

Seen from component side with upper side tracks.

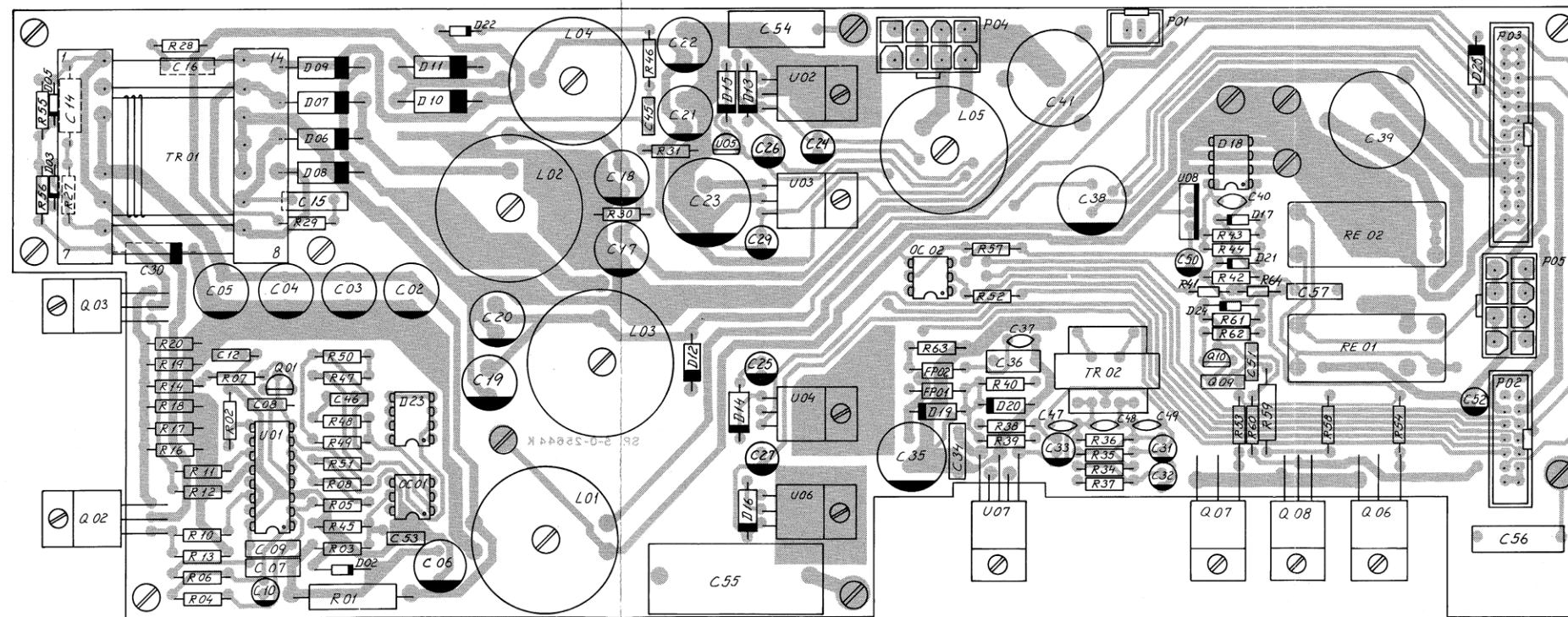

Seen from component side with lower side tracks.

PCB rev. 25644K

POWER SUPPLY UNIT MODULE 4

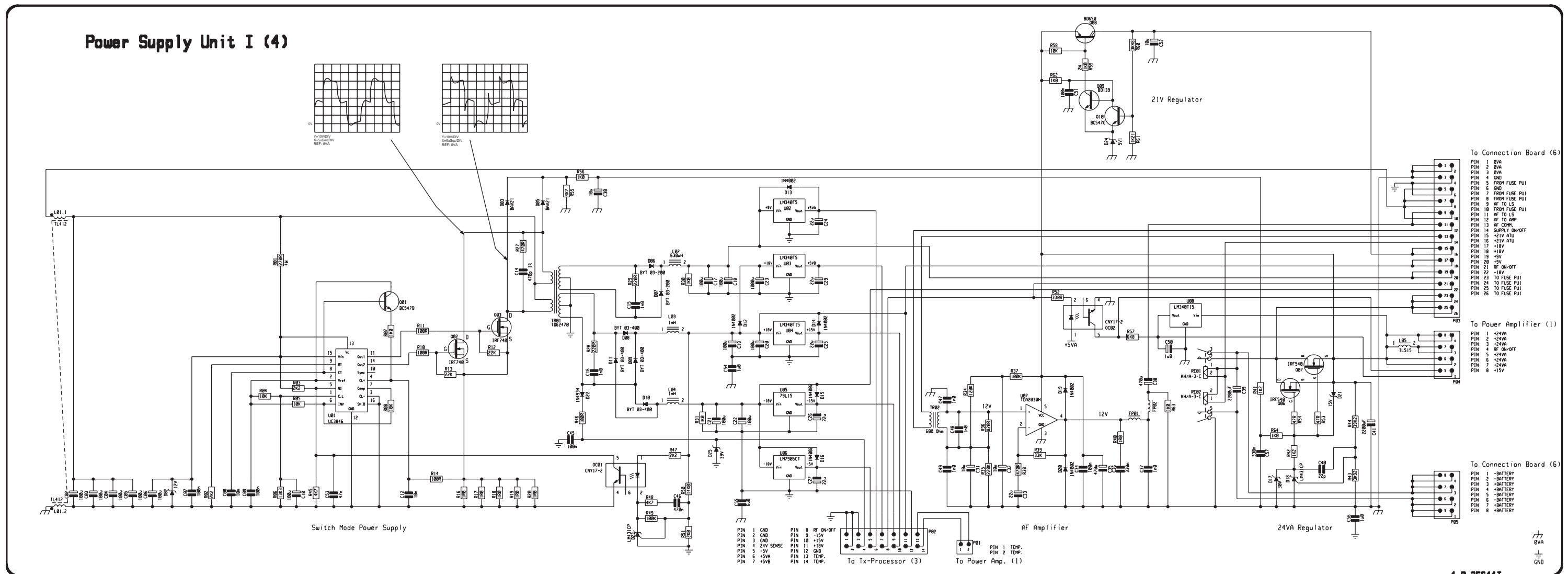

This diagram is valid for PCB rev. 25644K

5.6 COMPONENT LOCATION CONNECTION BOARD MODULE 6

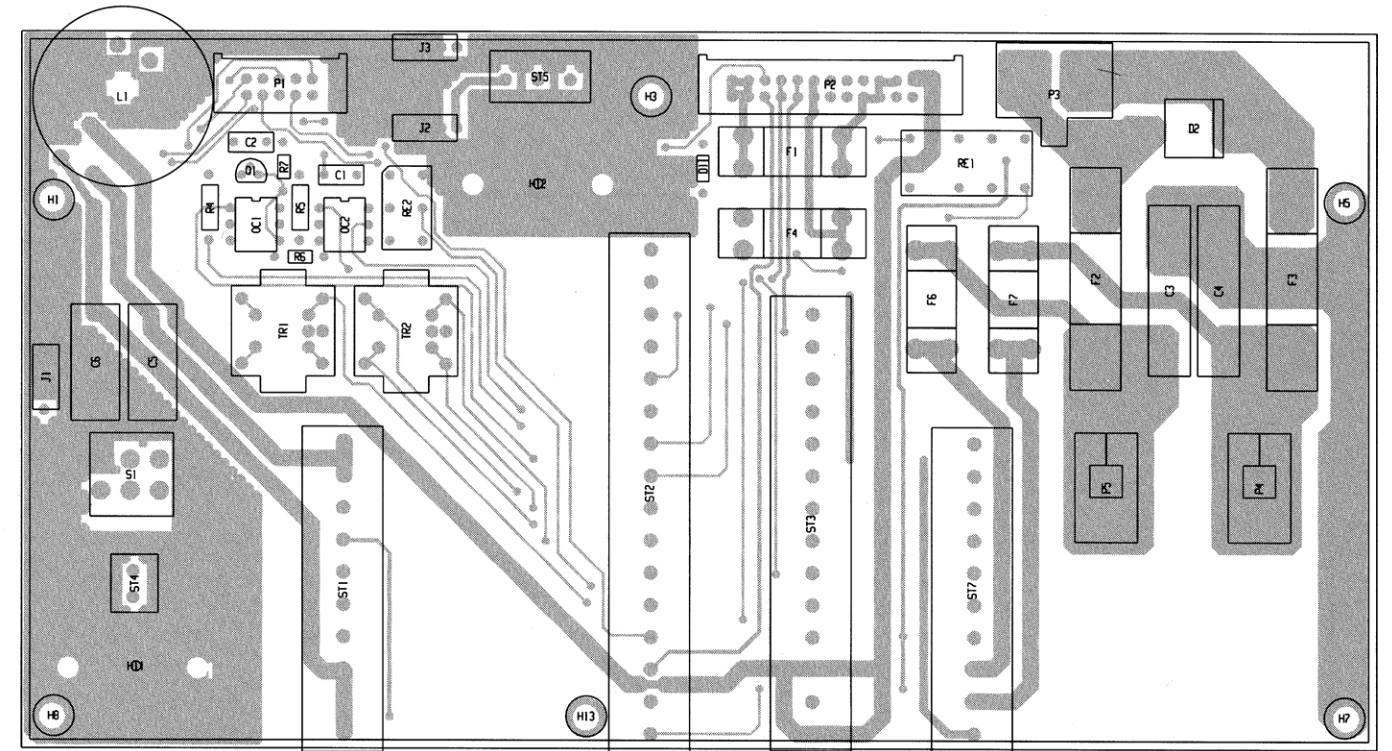

Seen from component side with upper side tracks.

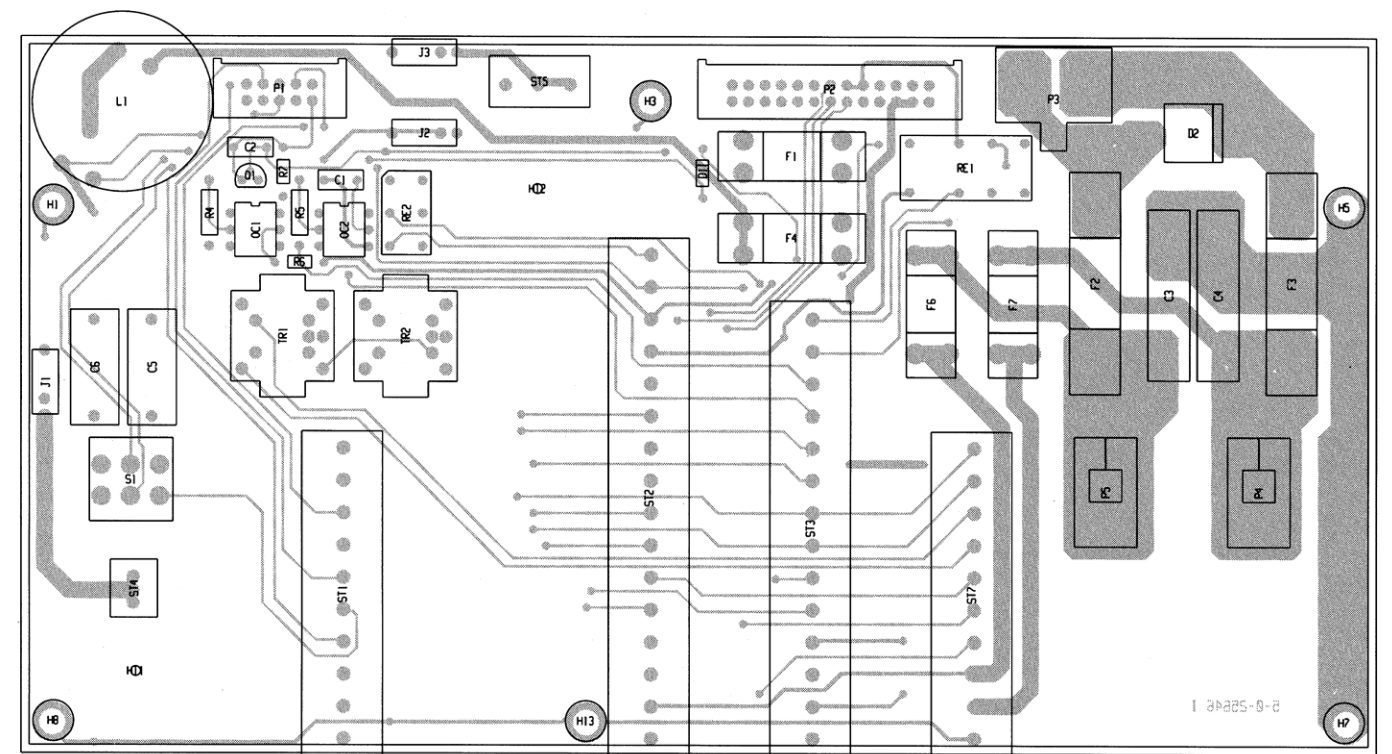

Seen from component side with lower side tracks.
PCB rev. 256461

CONNECTION BOARD MODULE 6

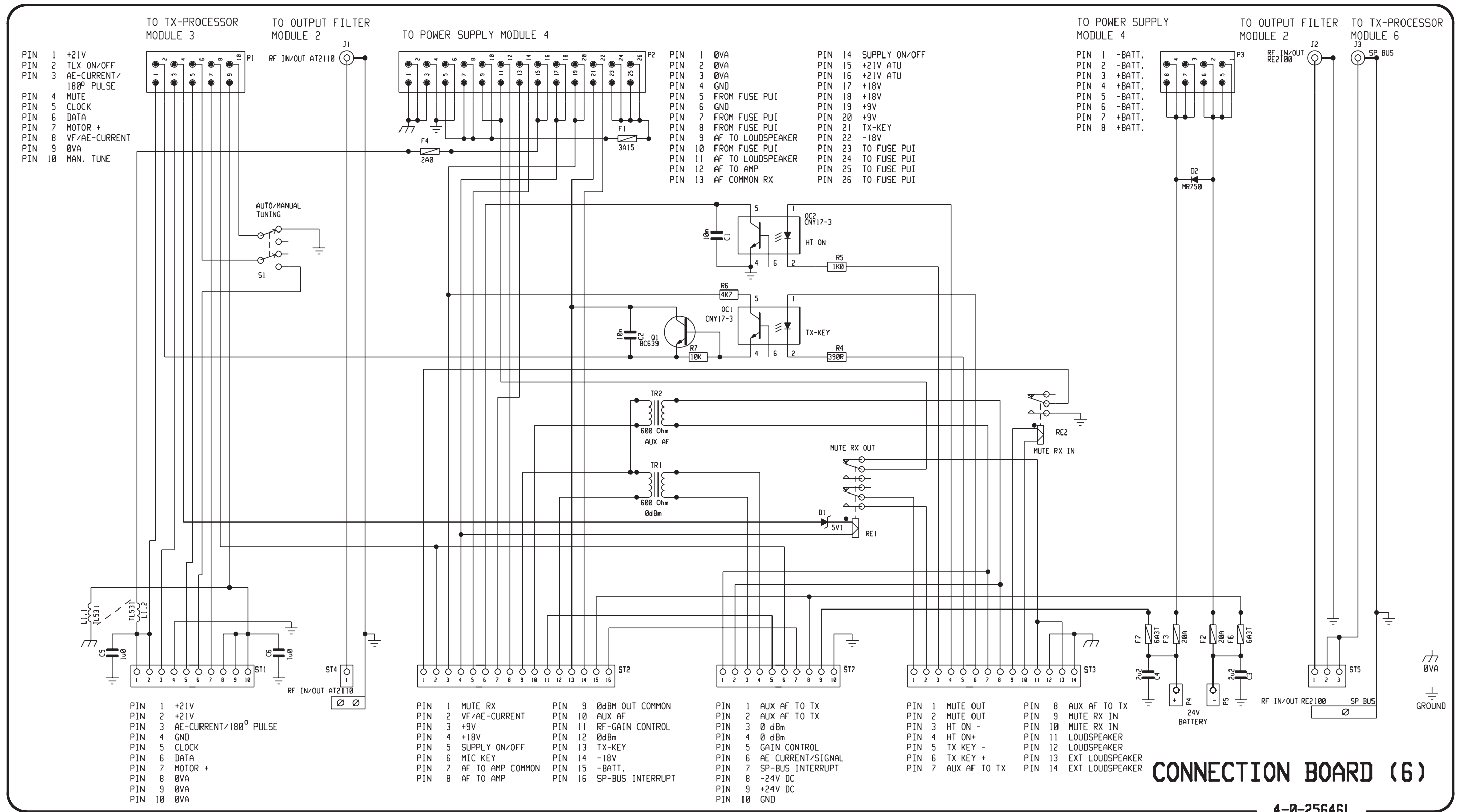

This diagram is valid for PCB rev. 25646 I

5.9 INTERCONNECTION CABLE PLAN

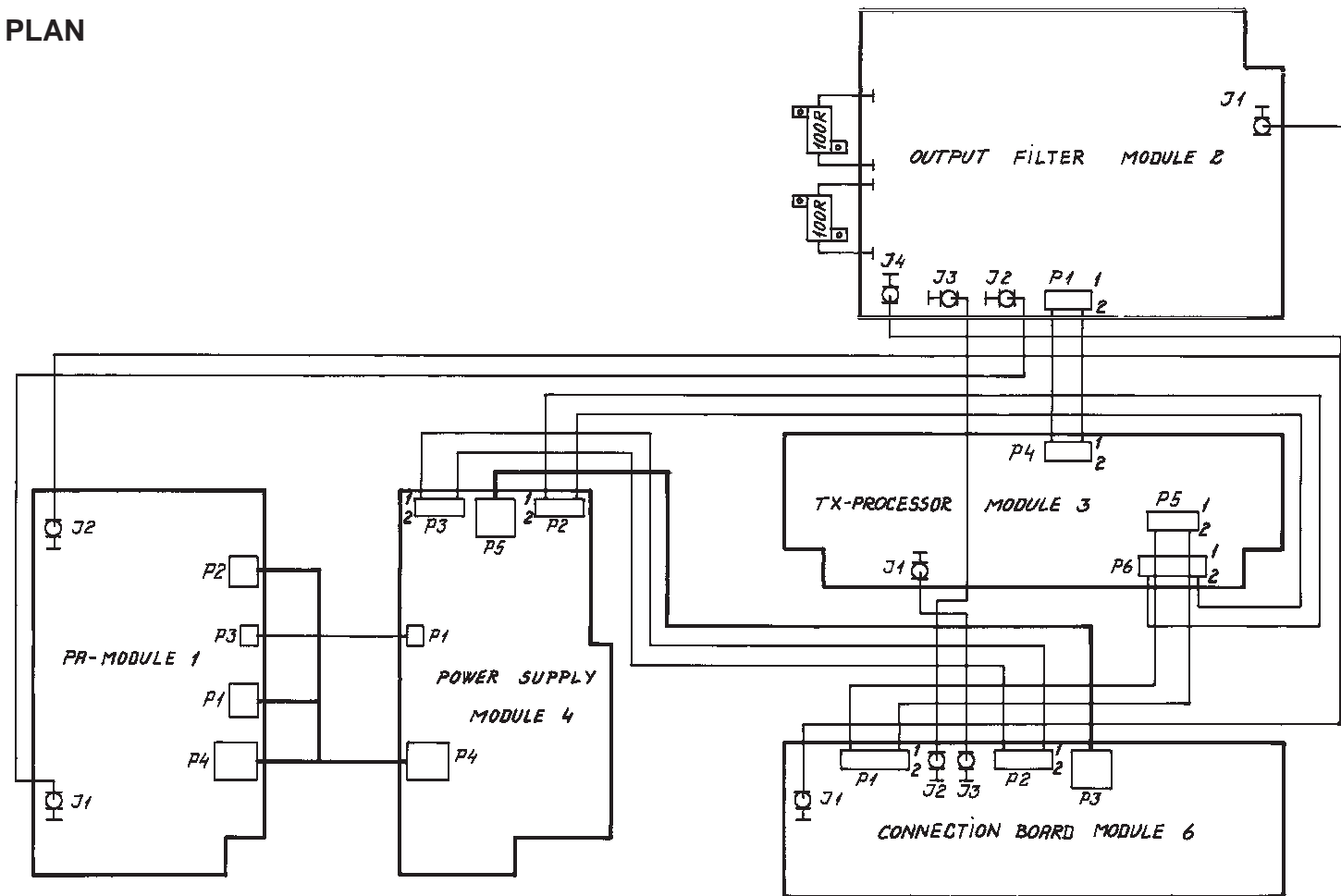

25895A

CABLE 1 : TX-PROCESSOR TO POWER SUPPLY I

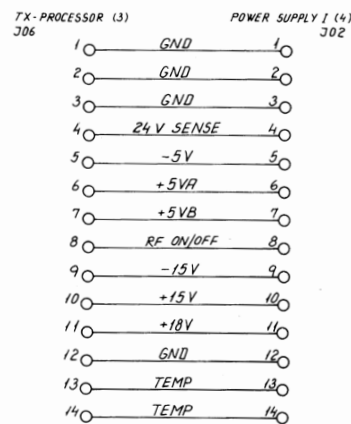

CABLE 2 : TX-PROCESSOR TO OUTPUT FILTER

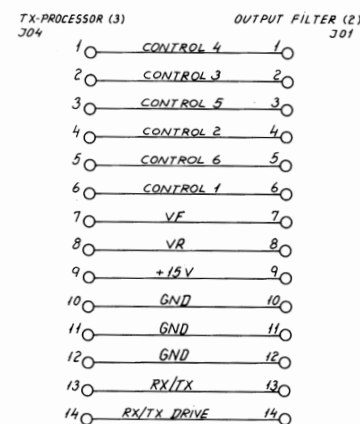

CABLE 4 : POWER SUPPLY I TO CONNECTION BOARD

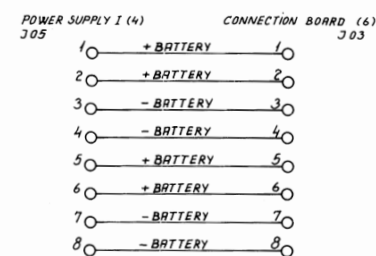

CABLE 5 : POWER SUPPLY I TO CONNECTION BOARD

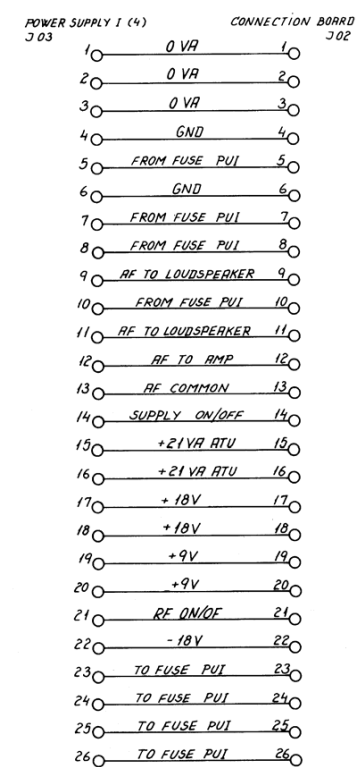

CABLE 6 : POWER SUPPLY I TO POWER AMPLIFIER

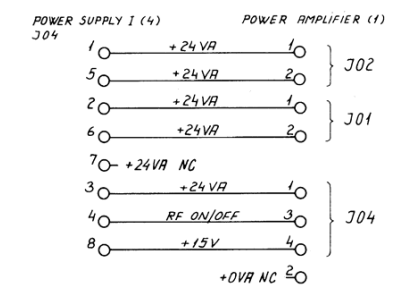

CABLE 3 : TX-PROCESSOR TO CONNECTION BOARD

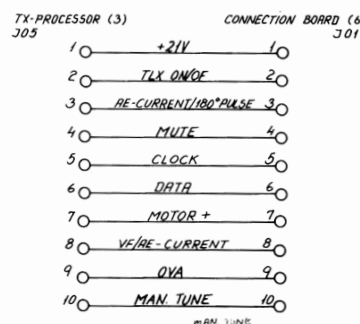

CABLE 7 : POWER SUPPLY I TO POWER AMPLIFIER

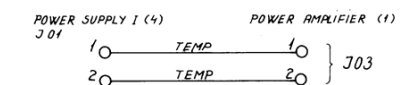

CABLE 8-9 : OUTPUT FILTER TO POWER AMPLIFIER

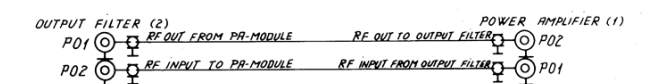

CABLE 10-11-12 : OUTPUT FILTER TO CONNECTION BOARD

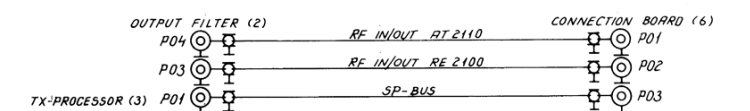

9315

25894A

CONTENTS

6 PARTS LIST

6 PARTS LIST

HF SSB T2130		MF/HF TRANSMITTER	ECI A/S	HF SSB T2130	802130
POSITION	DESCRIPTION		MANUFACTOR	TYPE	PART NO.
VARIOUS	COVER WITH STREAMER T2130		ECI A/S	3-0-25968	225968
VARIOUS	COAX CABLE RE2100 (RED)	LENGTH 10m	ECI A/S	3-0-27081	527081
VARIOUS	COAX CABLE RE2100 (BLUE)	LENGTH 10m	ECI A/S	3-0-27082	527082
VARIOUS	STICKER MANUAL TUNE	T2130	HESTBECH	9-0-25819	53.304
VARIOUS	SPARE FUSES FOR T2130	T2130	ECI A/S	0-0-26121	726121
VARIOUS	LASHING KIT FOR T2130	AND N2160 / N2161	ECI A/S	0-0-26141	726141
VARIOUS	GLOW DISCHARG.LAMP AT2110		S.P.RADIO A/S	0-0-27740	727740
VARIOUS	JUMPER KIT 6/1200W 726391	HF SSB 600/1200W	ECI A/S	0-0-27767	727767
VARIOUS	MANUAL T2130 ENGLISH		S.P.RADIO A/S	Ver.:	M2130GB

BASE UNIT T2130		T2130	S.P.RADIO A/S	712130	
POSITION	DESCRIPTION		MANUFACTOR	TYPE	PART NO.
VARIOUS	INTERCONNECTION CABLE	8-8 POLES L=100mm	ECI A/S	3-0-26012A	526012
VARIOUS	INTERCONNECTION CABLE	8-4+2+2 POLES L=120mm	ECI A/S	3-0-26013A	526013
VARIOUS	COAX CABLE •3x37,5cm/RED		ECI A/S	3-0-26075	526075
VARIOUS	COAX CABLE •3x37,5cm/YELL		ECI A/S	3-0-26076	526076
VARIOUS	COAX CABLE •3x23cm/BLUE		ECI A/S	3-0-26077	526077
VARIOUS	COAX CABLE •3x59,5cm/BLAC		ECI A/S	3-0-26078	526078
VARIOUS	COAX CABLE •3x52,3cm		ECI A/S	3-0-26079	526079
VARIOUS	INTERCONNECTION CABLE	2 POLES L= 50mm	ECI A/S	3-0-26092A	526092
VARIOUS	INTERCONNECTION CABLE	26 POLES L=95mm	3M	3-0-26080A	56.018
VARIOUS	INTERCONNECTION CABLE	14 POLES L=120mm	3M	3-0-26081A	56.019
VARIOUS	INTERCONNECTION CABLE	14 POLES L=45mm	3M	3-0-26082A	56.020
VARIOUS	INTERCONNECTION CABLE	10 POLES L=305mm	3M	3-0-26083A	56.021
-1	PA MODULE 1	T2130	ECI A/S	4-6-25641J / 4-0-25641H	625641
-2	OUT-PUT FILTER MODULE 2	T2130	ECI A/S	5-0-25642J / 4-0-25642M	625642
-3	TX-PROCESSOR MODULE 3	T2130	ECI A/S	5-0-25643M / 4-0-25643O	625643
-4	POWER SUPPLY I MODULE 4	T2130	ECI A/S	5-0-25644K / 4-0-25644J	625644
-6	CONNECTION BOARD MODULE 6	T2130	ECI A/S	5-0-25646I / 4-0-25646L	625646

PA MODULE 1		T2130	ECI A/S	4-6-25641J / 4-0-25641H	625641
POSITION	DESCRIPTION		MANUFACTOR	TYPE	PART NO.
C1-1	CAPACITOR MKT	100nF 10% 100VDC	ERO	MKT 1818-410/01 5-G	11.180
C2-1	CAPACITOR MKT	100nF 10% 100VDC	ERO	MKT 1818-410/01 5-G	11.180
C3-1	CAPACITOR MKT	100nF 10% 100VDC	ERO	MKT 1818-410/01 5-G	11.180
C4-1	CAPACITOR CERAMIC	10nF -20/+80% CL2 50VDC	KCK	RT-HE70 SK YF 103 Z	15.170
C5-1	CAPACITOR MKT	100nF 10% 100VDC	ERO	MKT 1818-410/01 5-G	11.180
C6-1	CAPACITOR POLYSTYRENE	620PF 1% 630V	#PHILIPS	2222 431 86201	10.435
C7-1	CAPACITOR MKT	100nF 10% 100VDC	ERO	MKT 1818-410/01 5-G	11.180
C8-1	CAPACITOR ELECTROLYTIC	10uF -10/+50% 63VDC	PHILIPS	2222 030 38109	14.546
C9-1	CAPACITOR CERAMIC	10nF -20/+80% CL2 50VDC	KCK	RT-HE70 SK YF 103 Z	15.170
C12-1	CAPACITOR CERAMIC	10nF -20/+80% CL2 50VDC	KCK	RT-HE70 SK YF 103 Z	15.170
C13-1	CAPACITOR MKT	100nF 10% 100VDC	ERO	MKT 1818-410/01 5-G	11.180
C14-1	CAPACITOR MKT	100nF 10% 100VDC	ERO	MKT 1818-410/01 5-G	11.180
C15-1	CAPACITOR MKT	100nF 10% 100VDC	ERO	MKT 1818-410/01 5-G	11.180
C16-1	CAPACITOR ELECTROLYTIC	100uF -10/+50% 25VDC	ERO	EKM 00 CC 310 E G5	14.610
C17-1	CAPACITOR MKP	10n 10% 400V	ERO	MRP 1841-310/40 5 G	13.425
C18-1	CAPACITOR MKP	10n 10% 400V	ERO	MRP 1841-310/40 5 G	13.425
C19-1	CAPACITOR CERAMIC	10nF -20/+80% CL2 50VDC	KCK	RT-HE70 SK YF 103 Z	15.170
C20-1	CAPACITOR MKT	100nF 10% 100VDC	ERO	MKT 1818-410/01 5-G	11.180
C21-1	CAPACITOR MKT	470nF 5% 63VDC	ERO	MKT 1826-447/06 4-G	11.187
C22-1	CAPACITOR ELECTROLYTIC	10uF -10/+50% 63VDC	PHILIPS	2222 030 38109	14.546
C23-1	CAPACITOR MKT	100nF 10% 100VDC	ERO	MKT 1818-410/01 5-G	11.180
C24-1	CAPACITOR MKT	100nF 10% 100VDC	ERO	MKT 1818-410/01 5-G	11.180
C25-1	CAPACITOR MKT	100nF 10% 100VDC	ERO	MKT 1818-410/01 5-G	11.180
C26-1	CAPACITOR ELECTROLYTIC	10uF -10/+50% 63VDC	PHILIPS	2222 030 38109	14.546
C27-1	CAPACITOR MKT	100nF 10% 100VDC	ERO	MKT 1818-410/01 5-G	11.180
C28-1	CAPACITOR MKT	100nF 10% 100VDC	ERO	MKT 1818-410/01 5-G	11.180
C29-1	CAPACITOR MKT	100nF 10% 100VDC	ERO	MKT 1818-410/01 5-G	11.180
C30-1	CAPACITOR MKT	100nF 10% 100VDC	ERO	MKT 1818-410/01 5-G	11.180

POSITION	DESCRIPTION		MANUFACTURER	TYPE	PART NO.
C31-1	CAPACITOR MKT	100nF 10% 100VDC	ERO	MKT 1818-410/01 5-G	11.180
C32-1	CAPACITOR MKT	100nF 10% 100VDC	ERO	MKT 1818-410/01 5-G	11.180
C33-1	CAPACITOR ELECTROLYTIC	470uF -20/+50% 10VDC	ELNA	RJ2-10-V-471-M-F	14.633
C34-1	CAPACITOR ELECTROLYTIC	10uF 20% 35VDC	ELNA	RJ2-35-V-100-M-T58	14.512
C37-1	CAPACITOR MKT	100nF 10% 100VDC	ERO	MKT 1818-410/01 5-G	11.180
C38-1	CAPACITOR CERAMIC	160pF 5% N150 50VDC	KCK	RT-HE90-SK PH 161 J	15.842
C40-1	CAPACITOR MKT	47nF 10% 250VDC	ERO	MKT 1818-347/25 5G	11.166
C41-1	CAPACITOR MKT	47nF 10% 250VDC	ERO	MKT 1818-347/25 5G	11.166
C42-1	CAPACITOR MKT	47nF 10% 250VDC	ERO	MKT 1818-347/25 5G	11.166
C43-1	CAPACITOR MKT	47nF 10% 250VDC	ERO	MKT 1818-347/25 5G	11.166
C44-1	CAPACITOR MKT	4.7NF 100V 10%	ERO	MKT1818-247/01-5G	11.145
C45-1	CAPACITOR MKT	4.7NF 100V 10%	ERO	MKT1818-247/01-5G	11.145
C46-1	CAPACITOR MICA	82pF 5% 500VDC	N-T-D	DM20 C 820 J 5	16.593
C49-1	CAPACITOR MICA	750pF 5% 500VDC	N-T-D	DM20 C 751 J 5	16.616
D1-1	DIODE HIGH SPEED	1N4448	PHILIPS	1N4448	25.147
D2-1	DIODE HIGH SPEED	1N4448	PHILIPS	1N4448	25.147
D3-1	DIODE HIGH SPEED	1N4448	PHILIPS	1N4448	25.147
FP4-1	FERRITE BEAD INDUCTOR		MURATA	BLO1RN1-A62T5	35.188
J1-1	SOCKET COAX 45 DEG.	PCB VERSION	TAIKO	TMP-J01X-A2	78.517
J2-1	SOCKET COAX 45 DEG.	PCB VERSION	TAIKO	TMP-J01X-A2	78.517
L1-1	CHOKE FIXED	180nH 10%	SIEMENS	B78108-T3181-K	20.338
L2-1	COIL	TL067	ECI A/S	6-0-20854A	400067
L3-1	COIL	TL067	ECI A/S	6-0-20854A	400067
L4-1	COIL	TL067	ECI A/S	6-0-20854A	400067
L5-1	COIL	TL067	ECI A/S	6-0-20854A	400067
L6-1	CHOKE FIXED	180nH 10%	SIEMENS	B78108-T3181-K	20.338
L7-1	COIL	TL067	ECI A/S	6-0-20854A	400067
P1-1	PLUG 2POLES		MOLEX	39-28-1023	78.215
P2-1	PLUG 2POLES		MOLEX	39-28-1023	78.215
P3-1	PLUG	2 POLES	AMP	0-826375-2	78.102
P4-1	PLUG 4 POLES		MOLEX	39-28-1043	78.216
Q1-1	TRANSISTOR AF	PNP TO-92 BC328	MOTOROLA	BC328	28.050
Q2-1	TRANSISTOR AF	BC547B NPN TO-92	PHILIPS	BC547B-126	28.067
Q3-1	TRANSISTOR RF MED.POWER	NPN TO-39 2N3553	PHILIPS	2N3553	29.315
Q4-1	TRANSISTOR RF MED.POWER	NPN TO-39 2N3553	PHILIPS	2N3553	29.315
Q5-1	TRANSISTOR AF	BC548 NPN TO-92	PHILIPS	BC548 (-A/-B/-C)126	28.070
Q6-1	TRANSISTOR RF POWER	MRF426 MATCHED PAIR (hFE)	MOTOROLA	MRF 426 hFE SORTED	29.266
Q7-1	TRANSISTOR RF POWER	MRF426 MATCHED PAIR (hFE)	MOTOROLA	MRF 426 hFE SORTED	29.266
Q8-1	TRANSISTOR AF POWER NPN	DARLINGTON BD645/BDX53	MOTOROLA	BDX53	29.122
Q9-1	TRANSISTOR RF POWER	MATCHED PAIR (HFE)	THOMSON	SD1729-12 PAR	29.267
Q10-1	TRANSISTOR RF POWER	MATCHED PAIR (HFE)	THOMSON	SD1729-12 PAR	29.267
Q11-1	TRANSISTOR AF	BC548 NPN TO-92	PHILIPS	BC548 (-A/-B/-C)126	28.070
Q12-1	TRANSISTOR AF POWER NPN	DARLINGTON BD645/BDX53	MOTOROLA	BDX53	29.122
R1-1	RESISTOR MF	68 OHM 5% 0.4W	PHILIPS	2322 181 53689	01.170
R2-1	RESISTOR MF	680 OHM 5% 0.4W	PHILIPS	2322 181 53681	01.195
R3-1	RESISTOR MF	1k8 OHM 5% 0.4W	PHILIPS	2322 181 53182	01.206
R4-1	RESISTOR MF	10 OHM 5% 0.4W	PHILIPS	2322 181 53109	01.150
R5-1	RESISTOR MF	10k OHM 5% 0.4W	PHILIPS	2322 181 53103	01.225
R6-1	RESISTOR MF	470 OHM 5% 0.4W	PHILIPS	2322 181 53471	01.191
R7-1	RESISTOR MF	470 OHM 5% 0.4W	PHILIPS	2322 181 53471	01.191
R8-1	RESISTOR MF	820 OHM 5% 0.4W	PHILIPS	2322 181 53821	01.197
R9-1	RESISTOR PMF	120 OHM 5% 2W	PHILIPS	2322 191 31201	04.178
R10-1	RESISTOR PMF	120 OHM 5% 2W	PHILIPS	2322 191 31201	04.178
R11-1	RESISTOR MF	820 OHM 5% 0.4W	PHILIPS	2322 181 53821	01.197
R12-1	RESISTOR MF	15 OHM 5% 0.4W	PHILIPS	2322 181 53159	01.154
R13-1	RESISTOR MF	9k1 OHM 5% 0.4W	PHILIPS	2322 181 53912	01.224
R14-1	PRESET CERMET	200 OHM 10% 0.5W	BOURNS	3386P-Y91-201	07.884
R15-1	RESISTOR MF	10k OHM 5% 0.4W	PHILIPS	2322 181 53103	01.225
R16-1	RESISTOR MF	3k3 OHM 5% 0.4W	PHILIPS	2322 181 53332	01.212
R17-1	RESISTOR MF	4k7 OHM 5% 0.4W	PHILIPS	2322 181 53472	01.216
R18-1	RESISTOR MF	10k OHM 5% 0.4W	PHILIPS	2322 181 53103	01.225
R19-1	RESISTOR MF	10k OHM 5% 0.4W	PHILIPS	2322 181 53103	01.225
R20-1	RESISTOR MF	10k OHM 5% 0.4W	PHILIPS	2322 181 53103	01.225
R23-1	RESISTOR MF	4k7 OHM 5% 0.4W	PHILIPS	2322 181 53472	01.216
R24-1	RESISTOR MF	470k OHM 5% 0.4W	PHILIPS	2322 181 53474	01.266
R25-1	RESISTOR MF	3k3 OHM 5% 0.4W	PHILIPS	2322 181 53332	01.212
R26-1	RESISTOR MF	47 OHM 5% 0.4W	PHILIPS	2322 181 53479	01.166
R27-1	RESISTOR MF	12k OHM 5% 0.4W	PHILIPS	2322 181 53123	01.227
R28-1	RESISTOR MF	22 OHM 5% 0.4W	PHILIPS	2322 181 53229	01.158
R29-1	RESISTOR MF	9k1 OHM 5% 0.4W	PHILIPS	2322 181 53912	01.224
R30-1	PRESET CERMET	200 OHM 10% 0.5W	BOURNS	3386P-Y91-201	07.884
R31-1	RESISTOR PMF	3R3 OHM 5% 2W	PHILIPS	2322 194 13338	04.124
R32-1	RESISTOR PMF	3R3 OHM 5% 2W	PHILIPS	2322 194 13338	04.124
R35-1	RESISTOR PMF	3R3 OHM 5% 2W	PHILIPS	2322 194 13338	04.124

POSITION	DESCRIPTION		MANUFACTOR	TYPE	PART NO.
R36-1	RESISTOR PMF	3R3 OHM 5% 2W	PHILIPS	2322 194 13338	04.124
R37-1	RESISTOR MF	10k OHM 5% 0.4W	PHILIPS	2322 181 53103	01.225
R38-1	RESISTOR PMF	22 OHM 5% 2W	PHILIPS	2322 194 13229	04.141
R39-1	RESISTOR PMF	22 OHM 5% 2W	PHILIPS	2322 194 13229	04.141
R40-1	RESISTOR MF	3k3 OHM 5% 0.4W	PHILIPS	2322 181 53332	01.212
R41-1	RESISTOR MF	10k OHM 5% 0.4W	PHILIPS	2322 181 53103	01.225
R42-1	RESISTOR MF	10k OHM 5% 0.4W	PHILIPS	2322 181 53103	01.225
R43-1	RESISTOR MF	10k OHM 5% 0.4W	PHILIPS	2322 181 53103	01.225
R44-1	RESISTOR MF	4k7 OHM 5% 0.4W	PHILIPS	2322 181 53472	01.216
R45-1	RESISTOR TEMP.SENSOR	2k0 2.5% AT 25 CENTIGRADE	SIEMENS	Q62705-K245, -K247	07.151
R46-1	RESISTOR MF	470k OHM 5% 0.4W	PHILIPS	2322 181 53474	01.266
R47-1	RESISTOR MF	3k3 OHM 5% 0.4W	PHILIPS	2322 181 53332	01.212
R48-1	RESISTOR MF	2R2 OHM 5% 0.4W	PHILIPS	2322 181 53228	01.133
R49-1	RESISTOR MF	12k OHM 5% 0.4W	PHILIPS	2322 181 53123	01.227
R50-1	RESISTOR MF	22 OHM 5% 0.4W	PHILIPS	2322 181 53229	01.158
R51-1	RESISTOR MF	8R2 OHM 5% 0.4W	PHILIPS	2322 181 53828	01.147
R52-1	RESISTOR MF	150 OHM 5% 0.4W	PHILIPS	2322 181 53151	01.179
R53-1	RESISTOR MF	33 OHM 5% 0.4W	PHILIPS	2322 181 53339	01.162
R54-1	RESISTOR MF	150 OHM 5% 0.4W	PHILIPS	2322 181 53151	01.179
R55-1	RESISTOR MF	100 OHM 5% 0.4W	PHILIPS	2322 181 53101	01.175
R56-1	RESISTOR MF	100 OHM 5% 0.4W	PHILIPS	2322 181 53101	01.175
TR1-1	TRANSFORMER	TL514	ECI A/S	6-0-25770B	400514
TR2-1	TRANSFORMER	TL514	ECI A/S	6-0-25770B	400514
TR3-1	TRANSFORMER	TL497	ECI A/S	6-0-25782A	400497
TR4-1	TRANSFORMER	TL498	ECI A/S	6-0-25783A	400498
TR5-1	TRANSFORMER	TL499	ECI A/S	6-0-25784A	400499
TR6-1	COIL	TL299	ECI A/S	6-0-23121A	400299
TR7-1	TRAFO	TL528	S.P.RADIO	6-0-25896B	400528
U1-1	DUAL OP AMP	LM358N	MOTOTOLA	LM 358N	31.100

COIL TL299 ECI A/S 6-0-23121A 400299

POSITION	DESCRIPTION		MANUFACTOR	TYPE	PART NO.
C2	CAPACITOR MICA	15nF 10% 100VDC	N-T-D	SDM20 C 153 K 1	18.145
C3	CAPACITOR MICA	15nF 10% 100VDC	N-T-D	SDM20 C 153 K 1	18.145
TR1	COAX CABLES FOR TL299		ECI A/S	500299 CABLES FOR TL299	500299
TR1	TOROIDE		*PHILIPS	4322 020 97200	35.027

OUT-PUT FILTER MODULE 2 T2130 ECI A/S 5-0-25642J / 4-0-25642M 625642

POSITION	DESCRIPTION		MANUFACTOR	TYPE	PART NO.
C1-2	CAPACITOR MKT	100nF 10% 100VDC	ERO	MKT 1818-410/01 5-G	11.180
C2-2	CAPACITOR MKT	100nF 10% 100VDC	ERO	MKT 1818-410/01 5-G	11.180
C3-2	CAPACITOR MKT	100nF 10% 100VDC	ERO	MKT 1818-410/01 5-G	11.180
C4-2	CAPACITOR MKT	100nF 10% 100VDC	ERO	MKT 1818-410/01 5-G	11.180
C5-2	CAPACITOR MKT	100nF 10% 100VDC	ERO	MKT 1818-410/01 5-G	11.180
C6-2	CAPACITOR MKT	100nF 10% 100VDC	ERO	MKT 1818-410/01 5-G	11.180
C7-2	CAPACITOR MKT	100nF 10% 100VDC	ERO	MKT 1818-410/01 5-G	11.180
C8-2	CAPACITOR MICA	1n8F 5% 500VDC	N-T-D	DM20 C 182 J 5	16.625
C9-2	CAPACITOR MICA	1n1F 5% 500VDC	N-T-D	DM20 C 112 J 5	16.620
C10-2	CAPACITOR MICA	680pF 5% 500VDC	N-T-D	DM20 C 681 J 5	16.615
C11-2	CAPACITOR MICA	430pF 5% 500VDC	N-T-D	DM20 C 431 J 5	16.609
C12-2	CAPACITOR MICA	240pF 5% 500VDC	N-T-D	DM20 C 241 J 5	16.604
C13-2	CAPACITOR MICA	150pF 5% 500VDC	N-T-D	DM20 C 151 J 5	16.599
C14-2	CAPACITOR MICA	2n0F 5% 500VDC	N-T-D	DM20 C 202 J 5	16.626
C15-2	CAPACITOR MICA	1n3F 5% 500VDC	N-T-D	DM20 C 132 J 5	16.622
C16-2	CAPACITOR MICA	750pF 5% 500VDC	N-T-D	DM20 C 751 J 5	16.616
C17-2	CAPACITOR MICA	510pF 5% 500VDC	N-T-D	DM20 C 511 J 5	16.611
C18-2	CAPACITOR MICA	270pF 5% 500VDC	N-T-D	DM20 C 271 J 5	16.603
C19-2	CAPACITOR MICA	160pF 5% 500VDC	N-T-D	DM20 C 161 J 5	16.600
C20-2	CAPACITOR MICA	1n8F 5% 500VDC	N-T-D	DM20 C 182 J 5	16.625
C21-2	CAPACITOR MICA	1n1F 5% 500VDC	N-T-D	DM20 C 112 J 5	16.620
C22-2	CAPACITOR MICA	680pF 5% 500VDC	N-T-D	DM20 C 681 J 5	16.615
C23-2	CAPACITOR MICA	430pF 5% 500VDC	N-T-D	DM20 C 431 J 5	16.609
C24-2	CAPACITOR MICA	240pF 5% 500VDC	N-T-D	DM20 C 241 J 5	16.604
C25-2	CAPACITOR MICA	150pF 5% 500VDC	N-T-D	DM20 C 151 J 5	16.599
C26-2	CAPACITOR MKT	100nF 10% 100VDC	ERO	MKT 1818-410/01 5-G	11.180

POSITION	DESCRIPTION		MANUFACTURER	TYPE	PART NO.
C27-2	CAPACITOR MKT	10nF 5% 250VDC	ERO	MKT 1818-310/25 4-G	11.167
C28-2	CAPACITOR CERAMIC	12pF 5% NPO 500VDC	KCK	RT-HM60-SK CH 120 J	15.575
C29-2	CAPACITOR CERAMIC	51pF 5% NPO 50VDC	KCK	RT-HE60-SK CH 510 J	15.110
C30-2	CAPACITOR CERAMIC	110pF 10% NPO 500VDC	KCK	RT-HM11-SK CH 111 K	15.140
C31-2	CAPACITOR TRIMMING	5-60pF PTFE *9	DAU	109.4901.060	17.210
C32-2	CAPACITOR MKT	2n2F 10% 400VDC	ERO	MKT 1818-222/63 5-G	11.143
C33-2	CAPACITOR MKT	2n2F 10% 400VDC	ERO	MKT 1818-222/63 5-G	11.143
C34-2	CAPACITOR CERAMIC	1n0F 10% CL2 500VDC	KCK	RT-HM60 SK YB 102 K	15.160
C35-2	CAPACITOR CERAMIC	1n0F 10% CL2 500VDC	KCK	RT-HM60 SK YB 102 K	15.160
C36-2	CAPACITOR MKT	1u0F 10% 63VDC	ERO	MKT 1818-510/06 5-G	11.138
C37-2	CAPACITOR MKT	1u0F 10% 63VDC	ERO	MKT 1818-510/06 5-G	11.138
C38-2	CAPACITOR MKT	10nF 5% 250VDC	ERO	MKT 1818-310/25 4-G	11.167
C39-2	CAPACITOR MKT	10nF 5% 250VDC	ERO	MKT 1818-310/25 4-G	11.167
C40-2	CAPACITOR MKT	10nF 5% 250VDC	ERO	MKT 1818-310/25 4-G	11.167
C41-2	CAPACITOR MKT	10nF 5% 250VDC	ERO	MKT 1818-310/25 4-G	11.167
C42-2	CAPACITOR MKT	100nF 10% 100VDC	ERO	MKT 1818-410/01 5-G	11.180
C43-2	CAPACITOR MKT	100nF 10% 100VDC	ERO	MKT 1818-410/01 5-G	11.180
C44-2	CAPACITOR MKT	100nF 10% 100VDC	ERO	MKT 1818-410/01 5-G	11.180
C45-2	CAPACITOR MKT	100nF 10% 100VDC	ERO	MKT 1818-410/01 5-G	11.180
C46-2	CAPACITOR MKT	100nF 10% 100VDC	ERO	MKT 1818-410/01 5-G	11.180
C47-2	CAPACITOR MKT	100nF 10% 100VDC	ERO	MKT 1818-410/01 5-G	11.180
C48-2	CAPACITOR MKT	100nF 10% 100VDC	ERO	MKT 1818-410/01 5-G	11.180
C49-2	CAPACITOR MICA	360pF 5% 500VDC	N-T-D	DM20 C 361 J 5	16.605
C50-2	CAPACITOR MICA	270pF 5% 500VDC	N-T-D	DM20 C 271 J 5	16.603
C51-2	CAPACITOR MICA	220pF 5% 500VDC	N-T-D	DM20 C 221 J 5	16.602
C52-2	CAPACITOR MICA	180pF 5% 500VDC	N-T-D	DM20 C 181 J 5	16.601
C53-2	CAPACITOR MICA	150pF 5% 500VDC	N-T-D	DM20 C 151 J 5	16.599
C54-2	CAPACITOR MICA	100pF 5% 500VDC	N-T-D	DM20 C 101 J 5	16.595
C55-2	CAPACITOR MICA	82pF 5% 500VDC	N-T-D	DM20 C 820 J 5	16.593
C56-2	CAPACITOR MICA	68pF 5% 500VDC	N-T-D	DM20 C 680 J 5	16.591
C57-2	CAPACITOR MICA	47pF 5% 200VDC	N-D-T	DM20 C 470 J 5	16.587
C58-2	CAPACITOR MICA	39pF 5% 500VDC	N-T-D	DM20 C 390 J 5	16.585
C59-2	CAPACITOR MICA	33pF 5% 500VDC	N-T-D	DM20 C 330 J 5	16.583
C60-2	CAPACITOR MICA	22pF 5% 500VDC	N-T-D	DM20 C 220 J 5	16.579
C61-2	CAPACITOR MKT	100nF 10% 100VDC	ERO	MKT 1818-410/01 5-G	11.180
C62-2	CAPACITOR MKT	100nF 10% 100VDC	ERO	MKT 1818-410/01 5-G	11.180
C63	CAPACITOR MICA	33pF 5% 500VDC	N-T-D	DM20 C 330 J 5	16.583
D9-2	DIODE SCHOTTKY BARRIER	70V/15mA 1N5711/5082-2800	SGS-THOMSON	1N5711	27.500
D10-2	DIODE SCHOTTKY BARRIER	70V/15mA 1N5711/5082-2800	SGS-THOMSON	1N5711	27.500
D11-2	DIODE HIGH SPEED	1N4448	PHILIPS	1N4448	25.147
D12-2	DIODE HIGH SPEED	1N4448	PHILIPS	1N4448	25.147
J1-2	SOCKET COAX 45 DEG.	PCB VERSION	TAIKO	TMP-J01X-A2	78.517
J2-2	SOCKET COAX 45 DEG.	PCB VERSION	TAIKO	TMP-J01X-A2	78.517
J3-2	SOCKET COAX 45 DEG.	PCB VERSION	TAIKO	TMP-J01X-A2	78.517
J4-2	SOCKET COAX 45 DEG.	PCB VERSION	TAIKO	TMP-J01X-A2	78.517
L1-2	COIL	TL525	ECI A/S	6-0-26000A	400525
L2-2	COIL	TL529	ECI A/S	6-0-26112	400529
L3-2	COIL	TL503	ECI A/S	6-0-25757B	400503
L4-2	COIL	TL505	ECI A/S	6-0-25759A	400505
L5-2	COIL	TL505	ECI A/S	6-0-25759A	400505
L6-2	COIL	TL506	ECI A/S	6-0-25760A	400506
L7-2	COIL	TL508	ECI A/S	6-0-25762A	400508
L8-2	COIL	TL532	ECI A/S	6-0-26312A	400532
L9-2	COIL	TL510	ECI A/S	6-0-25764A	400510
L10-2	COIL	TL511	ECI A/S	6-0-25765C	400511
L11-2	COIL	TL512	ECI A/S	6-0-25766A	400512
L12-2	COIL	TL513	ECI A/S	6-0-25767A	400513
L13-2	COIL	TL508	ECI A/S	6-0-25762A	400508
L14-2	COIL	TL532	ECI A/S	6-0-26312A	400532
L15-2	COIL	TL510	ECI A/S	6-0-25764A	400510
L16-2	COIL	TL511	ECI A/S	6-0-25765C	400511
L17-2	COIL	TL512	ECI A/S	6-0-25766A	400512
L18-2	COIL	TL513	ECI A/S	6-0-25767A	400513
L19-2	COIL	TL502	ECI A/S	6-0-25756A	400502
L20-2	COIL	TL529	ECI A/S	6-0-26112	400529
L21-2	COIL	TL504	ECI A/S	6-0-25758A	400504
L22-2	COIL	TL505	ECI A/S	6-0-25759A	400505
L23-2	COIL	TL513	ECI A/S	6-0-25767A	400513
L24-2	COIL	TL507	ECI A/S	6-0-25761A	400507
L25-2	CHOKE FIXED	39mH 5%	NEOSID	00 6122 43	20.218
L26-2	COIL	TL503	ECI A/S	6-0-25757B	400503
L27-2	COIL	TL510	ECI A/S	6-0-25764A	400510
L28-2	COIL	TL524	ECI A/S	6-0-25999B	400524
L29-2	COIL	TL530	ECI A/S	6-0-26113	400530

POSITION	DESCRIPTION		MANUFACTOR	TYPE	PART NO.
L30-2	COIL	TL523	ECI A/S	6-0-25998A	400523
L31-2	COIL	TL512	ECI A/S	6-0-25766A	400512
L32-2	COIL	TL507	ECI A/S	6-0-25761A	400507
L33-2	COIL	TL505	ECI A/S	6-0-25759A	400505
L34-2	COIL	TL521	ECI A/S	6-0-25996A	400521
L35-2	COIL	TL513	ECI A/S	6-0-25767A	400513
L36-2	COIL	TL522	ECI A/S	6-0-25997A	400522
L37-2	COIL	TL521	ECI A/S	6-0-25996A	400521
P1-2	PLUG	2x7 POLES	3M	3598-6002 / 7614-6002 JL	78.254
R1-2	RESISTOR MF	5k6 OHM 5% 0.4W	PHILIPS	2322 181 53562	01.218
R2-2	RESISTOR MF	100 OHM 5% 0.4W	PHILIPS	2322 181 53101	01.175
R3-2	RESISTOR MF	100 OHM 5% 0.4W	PHILIPS	2322 181 53101	01.175
R4-2	RESISTOR MF	100 OHM 5% 0.4W	PHILIPS	2322 181 53101	01.175
R5-2	RESISTOR MF	100 OHM 5% 0.4W	PHILIPS	2322 181 53101	01.175
R6-2	RESISTOR MF	100 OHM 5% 0.4W	PHILIPS	2322 181 53101	01.175
R7-2	RESISTOR MF	5k6 OHM 5% 0.4W	PHILIPS	2322 181 53562	01.218
R8-2	RESISTOR MF	5k6 OHM 5% 0.4W	PHILIPS	2322 181 53562	01.218
R9-2	RESISTOR MF	22k OHM 5% 0.4W	PHILIPS	2322 181 53223	01.233
R10-2	RESISTOR MF	22k OHM 5% 0.4W	PHILIPS	2322 181 53223	01.233
R11-2	RESISTOR MF	220k OHM 5% 0.4W	PHILIPS	2322 181 53224	01.258
R12-2	RESISTOR MF	220k OHM 5% 0.4W	PHILIPS	2322 181 53224	01.258
R13-2	RESISTOR MF	150k OHM 5% 0.4W	PHILIPS	2322 181 53154	01.254
R14-2	RESISTOR MF	150k OHM 5% 0.4W	PHILIPS	2322 181 53154	01.254
R15-2	RESISTOR MF	33k OHM 5% 0.4W	PHILIPS	2322 181 53333	01.237
R16-2	RESISTOR MF	33k OHM 5% 0.4W	PHILIPS	2322 181 53333	01.237
R17-2	RESISTOR MF	100k OHM 5% 0.4W	PHILIPS	2322 181 53104	01.250
R18-2	RESISTOR MF	100k OHM 5% 0.4W	PHILIPS	2322 181 53104	01.250
R19-2	RESISTOR MF	47 OHM 5% 0.4W	PHILIPS	2322 181 53479	01.166
R20-2	RESISTOR MF	47 OHM 5% 0.4W	PHILIPS	2322 181 53479	01.166
R21-2	RESISTOR POWER	100 OHM 5% 5W NON INDUCT.	ARCOL	NHS 10 100R 5%	06.374
R22-2	RESISTOR POWER	100 OHM 5% 5W NON INDUCT.	ARCOL	NHS 10 100R 5%	06.374
R23-2	RESISTOR POWER	100 OHM 5% 5W NON INDUCT.	ARCOL	NHS 10 100R 5%	06.374
R24-2	RESISTOR POWER	100 OHM 5% 5W NON INDUCT.	ARCOL	NHS 10 100R 5%	06.374
R25-2	RESISTOR POWER	100 OHM 5% 5W NON INDUCT.	ARCOL	NHS 10 100R 5%	06.374
R26-2	RESISTOR POWER	100 OHM 5% 5W NON INDUCT.	ARCOL	NHS 10 100R 5%	06.374
R27-2	RESISTOR WIRE WOUND	100 OHM 5% 25W NON INDUCT	ARCOL	NHS-25-100-5% &	06.375
R28-2	RESISTOR WIRE WOUND	100 OHM 5% 25W NON INDUCT	ARCOL	NHS-25-100-5% &	06.375
RE1-2	RELAY 12VDC DPDT 1.25A	M1B-12-H/AZ 820-2C212DE	MEISEI	M1B-12-H	21.295
RE2-2	RELAY 12VDC DPDT 1.25A	M1B-12-H/AZ 820-2C212DE	MEISEI	M1B-12-H	21.295
RE3-2	RELAY 12VDC DPDT 1.25A	M1B-12-H/AZ 820-2C212DE	MEISEI	M1B-12-H	21.295
RE4-2	RELAY 12VDC DPDT 1.25A	M1B-12-H/AZ 820-2C212DE	MEISEI	M1B-12-H	21.295
RE5-2	RELAY 12VDC DPDT 1.25A	M1B-12-H/AZ 820-2C212DE	MEISEI	M1B-12-H	21.295
RE6-2	RELAY 12VDC DPDT 1.25A	M1B-12-H/AZ 820-2C212DE	MEISEI	M1B-12-H	21.295
RE7-2	RELAY 12VDC DPDT 1.25A	M1B-12-H/AZ 820-2C212DE	MEISEI	M1B-12-H	21.295
RE8-2	RELAY 12VDC DPDT 1.25A	M1B-12-H/AZ 820-2C212DE	MEISEI	M1B-12-H	21.295
RE9-2	RELAY 12VDC DPDT 1.25A	M1B-12-H/AZ 820-2C212DE	MEISEI	M1B-12-H	21.295
RE10-2	RELAY 12VDC DPDT 1.25A	M1B-12-H/AZ 820-2C212DE	MEISEI	M1B-12-H	21.295
RE11-2	RELAY 12VDC DPDT 1.25A	M1B-12-H/AZ 820-2C212DE	MEISEI	M1B-12-H	21.295
RE12-2	RELAY 12VDC DPDT 1.25A	M1B-12-H/AZ 820-2C212DE	MEISEI	M1B-12-H	21.295
RE13-2	RELAY 12VDC DPDT 1.25A	M1B-12-H/AZ 820-2C212DE	MEISEI	M1B-12-H	21.295
RE14-2	RELAY 12VDC DPDT 1.25A	M1B-12-H/AZ 820-2C212DE	MEISEI	M1B-12-H	21.295
RE15	RELAY 12VDC 1A 1 SHIFT	V23026-A1002-B201	SIEMENS	V23026-A1002-B201	21.029
TR1-2	TRANSFORMER	TL501	ECI A/S	6-0-25786	400501
U1-2	QUAD OP.AMP.	324	NAT/SGS	LM324N	31.065

TX-PROCESSOR MODULE 3**T2130****ECI A/S****5-0-25643M / 4-0-25643O****625643**

POSITION	DESCRIPTION		MANUFACTOR	TYPE	PART NO.
VARIOUS	SOCKET	28POL	AMP	641605-3	30.928
VARIOUS	SHUNT CONNECTOR	FEMALE 2 POLES	AMP	142270-1	78.325
C1-3	CAPACITOR MKT	0.1uF 10% 63VDC	PHILIPS	2222 370 75104 (78104)	11.136
C2-3	CAPACITOR MKT	0.1uF 10% 63VDC	PHILIPS	2222 370 75104 (78104)	11.136
C3-3	CAPACITOR MKT	0.1uF 10% 63VDC	PHILIPS	2222 370 75104 (78104)	11.136
C4-3	CAPACITOR MKT	0.1uF 10% 63VDC	PHILIPS	2222 370 75104 (78104)	11.136
C5-3	CAPACITOR MKT	0.1uF 10% 63VDC	PHILIPS	2222 370 75104 (78104)	11.136
C6-3	CAPACITOR MKT	0.1uF 10% 63VDC	PHILIPS	2222 370 75104 (78104)	11.136
C7-3	CAPACITOR MKT	1000pF 10% 400VDC	ERO	MKT 1818-210/63 5-G	11.139
C8-3	CAPACITOR MKT	10nF 5% 63VDC	PHILIPS	2222 370 89103	11.134
C9-3	CAPACITOR MKT	0.1uF 10% 63VDC	PHILIPS	2222 370 75104 (78104)	11.136
C10-3	CAPACITOR MKT	0.1uF 10% 63VDC	PHILIPS	2222 370 75104 (78104)	11.136
C12-3	CAPACITOR MKT	1000pF 10% 400VDC	ERO	MKT 1818-210/63 5-G	11.139

POSITION	DESCRIPTION		MANUFACTURER	TYPE	PART NO.
C13-3	CAPACITOR MKT	0.1uF 10% 63VDC	PHILIPS	2222 370 75104 (78104)	11.136
C14-3	CAPACITOR MKT	0.1uF 10% 63VDC	PHILIPS	2222 370 75104 (78104)	11.136
C15-3	CAPACITOR MKT	0.1uF 10% 63VDC	PHILIPS	2222 370 75104 (78104)	11.136
C16-3	CAPACITOR MKT	0.1uF 10% 63VDC	PHILIPS	2222 370 75104 (78104)	11.136
C17-3	CAPACITOR MKT	0.1uF 10% 63VDC	PHILIPS	2222 370 75104 (78104)	11.136
C18-3	CAPACITOR ELECTROLYTIC	10uF 20% 35VDC	ELNA	RJ2-35-V-100-M-T58	14.512
C19-3	CAPACITOR MKT	0.1uF 10% 63VDC	PHILIPS	2222 370 75104 (78104)	11.136
C20-3	CAPACITOR ELECTROLYTIC	10uF 20% 35VDC	ELNA	RJ2-35-V-100-M-T58	14.512
C21-3	CAPACITOR MKT	0.1uF 10% 63VDC	PHILIPS	2222 370 75104 (78104)	11.136
C22-3	CAPACITOR MKT	0.1uF 10% 63VDC	PHILIPS	2222 370 75104 (78104)	11.136
C23-3	CAPACITOR MKT	0.1uF 10% 63VDC	PHILIPS	2222 370 75104 (78104)	11.136
C24-3	CAPACITOR MKT	0.1uF 10% 63VDC	PHILIPS	2222 370 75104 (78104)	11.136
C25-3	CAPACITOR ELECTROLYTIC	10uF 20% 35VDC	ELNA	RJ2-35-V-100-M-T58	14.512
C26-3	CAPACITOR MKT	0.1uF 10% 63VDC	PHILIPS	2222 370 75104 (78104)	11.136
C27-3	CAPACITOR MKT	0.1uF 10% 63VDC	PHILIPS	2222 370 75104 (78104)	11.136
C28-3	CAPACITOR MKT	0.1uF 10% 63VDC	PHILIPS	2222 370 75104 (78104)	11.136
C29-3	CAPACITOR MKT	0.1uF 10% 63VDC	PHILIPS	2222 370 75104 (78104)	11.136
C30-3	CAPACITOR MKT	0.1uF 10% 63VDC	PHILIPS	2222 370 75104 (78104)	11.136
C31-3	CAPACITOR MKT	0.1uF 10% 63VDC	PHILIPS	2222 370 75104 (78104)	11.136
C32-3	CAPACITOR MKT	1000pF 10% 400VDC	ERO	MKT 1818-210/63 5-G	11.139
C33-3	CAPACITOR MKT	0.1uF 10% 63VDC	PHILIPS	2222 370 75104 (78104)	11.136
C35-3	CAPACITOR MKT	10nF 5% 63VDC	PHILIPS	2222 370 89103	11.134
C36-3	CAPACITOR MKT	0.1uF 10% 63VDC	PHILIPS	2222 370 75104 (78104)	11.136
C37-3	CAPACITOR ELECTROLYTIC	4.7uF 20% 50VDC	ELNA	RJ2-50-V-4R7-M-T58	14.510
C38-3	CAPACITOR MKT	0.1uF 10% 63VDC	PHILIPS	2222 370 75104 (78104)	11.136
C39-3	CAPACITOR MKT	0.1uF 10% 63VDC	PHILIPS	2222 370 75104 (78104)	11.136
C40-3	CAPACITOR MKT	0.1uF 10% 63VDC	PHILIPS	2222 370 75104 (78104)	11.136
C41-3	CAPACITOR MKT	0.1uF 10% 63VDC	PHILIPS	2222 370 75104 (78104)	11.136
C42-3	CAPACITOR MKT	0.1uF 10% 63VDC	PHILIPS	2222 370 75104 (78104)	11.136
C43-3	CAPACITOR MKT	33nF 5% 100VDC	PHILIPS	2222 370 89333	11.176
C44-3	CAPACITOR MKT	0.1uF 10% 63VDC	PHILIPS	2222 370 75104 (78104)	11.136
C45-3	CAPACITOR MKT	0.1uF 10% 63VDC	PHILIPS	2222 370 75104 (78104)	11.136
C46-3	CAPACITOR MKT	33nF 5% 100VDC	PHILIPS	2222 370 89333	11.176
C47-3	CAPACITOR MKT	0.1uF 10% 63VDC	PHILIPS	2222 370 75104 (78104)	11.136
C48-3	CAPACITOR ELECTROLYTIC	10uF 20% 35VDC	ELNA	RJ2-35-V-100-M-T58	14.512
C49-3	CAPACITOR MKT	0.1uF 10% 63VDC	PHILIPS	2222 370 75104 (78104)	11.136
D1-3	DIODE ZENER	5.1V 5% 0.4W BZX79C5V1	PHILIPS	BZX79C5V1	26.527
D2-3	DIODE HIGH SPEED	1N4448	PHILIPS	1N4448	25.147
D4-3	DIODE ZENER	5.1V 5% 0.4W BZX79C5V1	PHILIPS	BZX79C5V1	26.527
D5-3	DIODE ZENER	5.1V 5% 0.4W BZX79C5V1	PHILIPS	BZX79C5V1	26.527
D6-3	DIODE HIGH SPEED	1N4448	PHILIPS	1N4448	25.147
D7-3	DIODE ZENER	9V1 5% 0.4W BZX79C9V1	PHILIPS	BZX79C9V1	26.546
D8-3	DIODE ZENER	18V 5% 0.4W BZX79C18	PHILIPS	BZX79C18	26.564
D9-3	DIODE HIGH SPEED	1N4448	PHILIPS	1N4448	25.147
D10-3	DIODE HIGH SPEED	1N4448	PHILIPS	1N4448	25.147
D11-3	DIODE HIGH SPEED	1N4448	PHILIPS	1N4448	25.147
D12-3	DIODE HIGH SPEED	1N4448	PHILIPS	1N4448	25.147
D13-3	DIODE HIGH SPEED	1N4448	PHILIPS	1N4448	25.147
D14-3	DIODE VOLTAGE REFERENCE	2.5V 1.5% LM385-2.5	MOTOROLA	LM385BZ-2.5	26.880
D15-3	DIODE HIGH SPEED	1N4448	PHILIPS	1N4448	25.147
D16-3	DIODE HIGH SPEED	1N4448	PHILIPS	1N4448	25.147
D17-3	DIODE HIGH SPEED	1N4448	PHILIPS	1N4448	25.147
D18-3	DIODE ZENER	5.1V 5% 0.4W BZX79C5V1	PHILIPS	BZX79C5V1	26.527
D19-3	DIODE HIGH SPEED	1N4448	PHILIPS	1N4448	25.147
D20-3	DIODE ZENER	3.9V 5% 0.4W BZX79C3V9	PHILIPS	BZX79C3V9	26.512
J1-3	SOCKET COAX 45 DEG.	PCB VERSION	TAIKO	TMP-J01X-A2	78.517
L1-3	CHOKE FIXED	180uH 5%	FASTRON	SMCC-181J-02	20.313
OC1-3	OPTO COUPLER	DUAL DARLINGTON	SHARP	PC 825	32.536
OC2-3	OPTO COUPLER	CNY17-2	MOTOROLA	CNY17-2	32.530
OC3-3	OPTO COUPLER	CNY17-2	MOTOROLA	CNY17-2	32.530
P2-3	MULTIPLUG	1/10" DIL SQ PINS 5x2 POL	AMP	826656-5	78.321
P3-3	SIL SQUARE PINS	2 POLES CC=1/10"	AMP	0-826629-2	78.322
P4-3	PLUG	2x7 POLES	3M	3598-6002 / 7614-6002 JL	78.254
P5-3	PLUG	2x5 POLES	3M	3654-6002 / 7610-6002 JL	78.251
P6-3	PLUG	2x7 POLES	3M	3598-6002 / 7614-6002 JL	78.254
Q1-3	TRANSISTOR AF	BC558 PNP TO-92	PHILIPS	BC558 (-A/-B/-C)-126	28.095
Q2-3	TRANSISTOR AF SMALL SIGNA	BC640	PHILIPS	BC640-126	28.124
Q3-3	TRANSISTOR AF	NPN BC639 TO-92	MOTOROLA	BC639ZL1	28.120
Q5-3	TRANSISTOR AF	NPN BC639 TO-92	MOTOROLA	BC639ZL1	28.120
Q6-3	TRANSISTOR AF POWER	PNP TO-220	MOTOROLA	BD808 (BD810)	29.095
Q7-3	TRANSISTOR AF SMALL SIGNA	BC640	PHILIPS	BC640-126	28.124
Q8-3	TRANSISTOR AF	NPN BC639 TO-92	MOTOROLA	BC639ZL1	28.120
Q9-3	TRANSISTOR AF	NPN BC639 TO-92	MOTOROLA	BC639ZL1	28.120
Q10-3	TRANSISTOR AF	NPN BC639 TO-92	MOTOROLA	BC639ZL1	28.120

POSITION	DESCRIPTION		MANUFACTOR	TYPE	PART NO.
Q11-3	TRANSISTOR AF	NPN BC639 TO-92	MOTOROLA	BC639ZL1	28.120
R1-3	RESISTOR MF	22k1 OHM 1% 0.6W	PHILIPS	2322 156 12213	03.441
R2-3	RESISTOR MF	1k96 OHM 1% 0.6W	PHILIPS	2322 156 11962	03.401
R3-3	RESISTOR MF	1M OHM 5% 0.33W	PHILIPS	2322 187 73105	02.544
R4-3	RESISTOR MF	10k OHM 5% 0.33W	PHILIPS	2322 187 73103	02.496
R5-3	RESISTOR MF	10k OHM 5% 0.33W	PHILIPS	2322 187 73103	02.496
R6-3	RESISTOR MF	12k OHM 5% 0.33W	PHILIPS	2322 187 73123	02.498
R7-3	RESISTOR MF	120k OHM 5% 0.33W	PHILIPS	2322 187 73124	02.522
R8-3	RESISTOR MF	2k7 OHM 5% 0.33W	PHILIPS	2322 187 73272	02.482
R9-3	RESISTOR MF	12k OHM 5% 0.33W	PHILIPS	2322 187 73123	02.498
R10-3	RESISTOR MF	1k2 OHM 5% 0.33W	PHILIPS	2322 187 73122	02.474
R11-3	RESISTOR MF	5.6 OHM 5% 0.33W	PHILIPS	2322 187 73568	02.418
R12-3	RESISTOR MF	5.6 OHM 5% 0.33W	PHILIPS	2322 187 73568	02.418
R13-3	RESISTOR MF	12k OHM 5% 0.33W	PHILIPS	2322 187 73123	02.498
R14-3	RESISTOR MF	51R1 OHM 1% 0.6W	PHILIPS	2322 156 15119	03.370
R15-3	RESISTOR MF	10k OHM 5% 0.33W	PHILIPS	2322 187 73103	02.496
R16-3	RESISTOR MF	39k2 OHM 1% 0.6W	PHILIPS	2322 156 13923	03.439
R18-3	RESISTOR MF	10k0 OHM 1% 0.6W	PHILIPS	2322 156 11003	03.427
R19-3	RESISTOR MF	1k00 OHM 1% 0.4W	PHILIPS	2322 156 11002	03.395
R20-3	RESISTOR MF	10k0 OHM 1% 0.6W	PHILIPS	2322 156 11003	03.427
R21-3	RESISTOR ARRAY	8x10k OHM 5% 1/8W	PANASONIC	EXB-F9E-103 J	08.630
R24-3	RESISTOR MF	330 OHM 5% 0.33W	PHILIPS	2322 187 73331	02.460
R25-3	RESISTOR MF	1k0 OHM 5% 0.33W	PHILIPS	2322 187 73102	02.472
R26-3	RESISTOR MF	10k OHM 5% 0.33W	PHILIPS	2322 187 73103	02.496
R27-3	RESISTOR MF	3k3 OHM 5% 0.33W	PHILIPS	2322 187 73332	02.484
R28-3	RESISTOR MF	330 OHM 5% 0.33W	PHILIPS	2322 187 73331	02.460
R29-3	RESISTOR MF	330 OHM 5% 0.33W	PHILIPS	2322 187 73331	02.460
R30-3	RESISTOR MF	5k1 OHM 5% 0.33W	PHILIPS	2322 187 73512	02.489
R31-3	RESISTOR MF	510 OHM 5% 0.33W	PHILIPS	2322 187 73511	02.465
R32-3	RESISTOR MF	4k7 OHM 5% 0.33W	PHILIPS	2322 187 73472	02.488
R33-3	RESISTOR MF	1k0 OHM 5% 0.33W	PHILIPS	2322 187 73102	02.472
R34-3	RESISTOR MF	510 OHM 5% 0.33W	PHILIPS	2322 187 73511	02.465
R35-3	RESISTOR MF	4k7 OHM 5% 0.33W	PHILIPS	2322 187 73472	02.488
R36-3	RESISTOR MF	1k0 OHM 5% 0.33W	PHILIPS	2322 187 73102	02.472
R37-3	RESISTOR MF	10k OHM 5% 0.33W	PHILIPS	2322 187 73103	02.496
R38-3	RESISTOR MF	10k OHM 5% 0.33W	PHILIPS	2322 187 73103	02.496
R39-3	RESISTOR MF	56k2 OHM 1% 0.6W	* PHILIPS	2322 156 15623	03.237
R40-3	RESISTOR MF	10k OHM 5% 0.33W	PHILIPS	2322 187 73103	02.496
R41-3	RESISTOR MF	1k0 OHM 5% 0.33W	PHILIPS	2322 187 73102	02.472
R42-3	RESISTOR MF	10k0 OHM 1% 0.6W	PHILIPS	2322 156 11003	03.427
R43-3	RESISTOR MF	10k OHM 5% 0.33W	PHILIPS	2322 187 73103	02.496
R44-3	RESISTOR	30 KOHM 1% 0.4W	*PHILIPS	2322 156 13003	03.460
R45-3	RESISTOR MF	2k0 OHM 1% 0.6W	* PHILIPS	2322 156 12002	03.403
R46-3	RESISTOR	8.06 KOHM 1% 0.4W	*PHILIPS	2322 156 18062	03.422
R47-3	RESISTOR MF	90k9 OHM 1% 0.6W	PHILIPS	2322 156 19093	03.476
R48-3	RESISTOR MF	100 OHM 5% 0.33W	PHILIPS	2322 187 73101	02.448
R49-3	RESISTOR MF	75k OHM 5% 0.33W	PHILIPS	2322 187 73753	02.517
R50-3	RESISTOR MF	2k2 OHM 5% 0.33W	PHILIPS	2322 187 73222	02.480
R51-3	RESISTOR MF	5k1 OHM 5% 0.33W	PHILIPS	2322 187 73512	02.489
R52-3	RESISTOR MF PRECISION	10k0 OHM 0.1% 75mW	DRALORIC	SMA 0207S-TK25-10k0-0.1%	06.130
R53-3	RESISTOR MF PRECISION	10k0 OHM 0.1% 75mW	DRALORIC	SMA 0207S-TK25-10k0-0.1%	06.130
R54-3	RESISTOR MF	1k00 OHM 1% 0.4W	PHILIPS	2322 156 11002	03.395
R55-3	RESISTOR MF	1k00 OHM 1% 0.4W	PHILIPS	2322 156 11002	03.395
R56-3	RESISTOR MF	3k92 OHM 1% 0.6W	PHILIPS	2322 156 13922	03.409
R57-3	RESISTOR MF PRECISION	2k58 OHM 0.1% 75mW	DRALORIC	SMA 0207S-TK25-2k58-0.1%	06.120
R58-3	RESISTOR MF PRECISION	642 OHM 0.1% 75mW	DRALORIC	SMA 0207S-TK25-642R-0.1%	06.110
R59-3	RESISTOR MF PRECISION	499 OHM 0.1% 75mW	PHILIPS	2322 141 50xxx	06.105
R60-3	RESISTOR MF	8k2 OHM 5% 0.33W	PHILIPS	2322 187 73822	02.494
R61-3	RESISTOR MF	10k OHM 5% 0.33W	PHILIPS	2322 187 73103	02.496
R62-3	RESISTOR MF	2k0 OHM 1% 0.6W	* PHILIPS	2322 156 12002	03.403
R63-3	RESISTOR MF	15k4 OHM 1% 0.6W	PHILIPS	2322 156 11543	03.456
R64-3	RESISTOR MF	2k0 OHM 1% 0.6W	* PHILIPS	2322 156 12002	03.403
R65-3	RESISTOR MF	3k92 OHM 1% 0.6W	PHILIPS	2322 156 13922	03.409
R66-3	RESISTOR MF	470 OHM 5% 0.33W	PHILIPS	2322 187 73471	02.464
R67-3	RESISTOR MF	5k1 OHM 5% 0.33W	PHILIPS	2322 187 73512	02.489
R68-3	RESISTOR MF	10k OHM 5% 0.33W	PHILIPS	2322 187 73103	02.496
R69-3	RESISTOR MF	5k1 OHM 5% 0.33W	PHILIPS	2322 187 73512	02.489
R70-3	RESISTOR MF	10k OHM 5% 0.33W	PHILIPS	2322 187 73103	02.496
R71-3	RESISTOR MF	1k87 OHM 1% 0.6W	PHILIPS	2322 156 11872	03.474
R72-3	RESISTOR MF	5k1 OHM 5% 0.33W	PHILIPS	2322 187 73512	02.489
R73-3	RESISTOR MF	220k OHM 5% 0.33W	PHILIPS	2322 187 73224	02.528
R74-3	RESISTOR MF	5k1 OHM 5% 0.33W	PHILIPS	2322 187 73512	02.489
R75-3	RESISTOR MF	220k OHM 5% 0.33W	PHILIPS	2322 187 73224	02.528
R76-3	RESISTOR MF	5k1 OHM 5% 0.33W	PHILIPS	2322 187 73512	02.489

POSITION	DESCRIPTION		MANUFACTOR	TYPE	PART NO.
R77-3	RESISTOR MF	470 OHM 5% 0.33W	PHILIPS	2322 187 73471	02.464
U1-3	PROGRAMMED PROM T2130	U1-3 T2130	ECI A/S	C10834- DC3A / 0-0-26103	726103
U2-3	MASTER PROCESSOR UNIT	8 BIT SERIAL INTERFACE	HITACHI	HD63B03YP	32.575
U3-3	uC SUPERVISORY CIRCUIT	MAX 690	MAXIM	MAX 690 CPA (EJA-MJA)	32.585
U4-3	NAND SCHMIDT TRIGGER	74HC132	TEXAS	74HC132N	34.521
U5-3	QUAD 2-INP.POS.AND GATE	74HC08	TEXAS	SN74HC08N	34.517
U6-3	DUAL OPERATIONAL AMP.	MC1458/LM1458	MOTOROLA	MC1458CP1	31.215
U7-3	3 to 8 LINE DECODER		MOTOROLA	MC74HC237N	34.550
U8-3	DARL.DRIVERS HI.CURR/VOLT	ULN2003/MC1413	MOTOROLA	MC1413P	31.077
U9-3	DARL.DRIVERS HI.CURR/VOLT	ULN2003/MC1413	MOTOROLA	MC1413P	31.077
U10-3	8 BIT SHIFT REG.SERIAL IO	74HC595	MOTOROLA	MC74HC595P / MC74HC595AN	34.502
U11-3	EEPROM 1k BIT SERIAL	93C46	NATIONAL	NM93C46N	32.709
U12-3	EEPROM 1k BIT SERIAL	93C46	NATIONAL	NM93C46N	32.709
U13-3	TRIPLE 3-INPUT NAND GATES	74HC10	TEXAS	SN74HC10	34.519
U14-3	8 BIT SHIFT REG.SERIAL IO	74HC595	MOTOROLA	MC74HC595P / MC74HC595AN	34.502
U15-3	ANALOG MULTIPLEXER	MC14053BCP	MOTOROLA*	MC14053BCP	33.201
U16-3	INTEGRATED CIRCUIT	TL072CP	TEXAS	TL072CP	31.710
U17-3	A/D CONVERTER 8 BIT RES.	4 CHANNELS ADC0834	NATIONAL	ADC0834CCN (BCN-CCJ-BCJ)	32.805
XR1-3	CERAMIC RESONATOR		MURATA	CST 800MT-TR	41.505

CONNECTION BOARD MODULE 6 T2130 ECI A/S 5-0-256461 / 4-0-25646L 625646

POSITION	DESCRIPTION		MANUFACTOR	TYPE	PART NO.
C1-6	CAPACITOR CERAMIC	10nF -20/+80% CL2 50VDC	KCK	RT-HE70 SK YF 103 Z	15.170
C2-6	CAPACITOR CERAMIC	10nF -20/+80% CL2 50VDC	KCK	RT-HE70 SK YF 103 Z	15.170
C3-6	CAPACITOR MKT	2u2F 10% 100VDC	ERO	MKT 1822-522/01 5 R	11.142
C4-6	CAPACITOR MKT	2u2F 10% 100VDC	ERO	MKT 1822-522/01 5 R	11.142
C5-6	CAPACITOR MKT	1u0F 10% 100VDC	PHILIPS	2222 373 25105	11.079
C6-6	CAPACITOR MKT	1u0F 10% 100VDC	PHILIPS	2222 373 25105	11.079
D1-6	DIODE ZENER	5.1V 5% 0.4W BZX79C5V1	PHILIPS	BZX79C5V1	26.527
D2-6	DIODE RECTIFIER 50V/6ADC	MR750, RL750	MOTOROLA	MR750 (51,52,54,56,60)	25.219
F1-6	FUSE	3.15A M *5x20mm	WICKMANN	919201	45.552
F2-6	FUSE	20AM 6.3x32mm	LITTELFUSE	314020.	45.631
F3-6	FUSE	20AM 6.3x32mm	LITTELFUSE	314020.	45.631
F4-6	FUSE	2AF 5x20mm	LITTELFUSE	217002.	45.556
F6-6	FUSE	5x20mm 6A3 T 250V	* ELU	17912006300	45.510
F7-6	FUSE	5x20mm 6A3 T 250V	* ELU	17912006300	45.510
J1-6	SOCKET COAX 45 DEG.	PCB VERSION	TAIKO	TMP-J01X-A2	78.517
J2-6	SOCKET COAX 45 DEG.	PCB VERSION	TAIKO	TMP-J01X-A2	78.517
J3-6	SOCKET COAX 45 DEG.	PCB VERSION	TAIKO	TMP-J01X-A2	78.517
L1-6	CHOKE	TL531	TRANS-ELECTRO	6-0-26309A	400531
OC1-6			SIEMENS	CNY17-4	82500001
OC2-6	OPTO COUPLER	CNY17-3	MOTOROLA	CNY17-3	32.533
P1-6	PLUG	2x5 POLES	3M	3654-6002 / 7610-6002 JL	78.251
P2-6	PLUG	2x13 POLES	3M	2526-6002 / 7626-6002 JL	78.248
P3-6	MULTIPLUG	2x4 POLES PCB VERSION	MOLEX	39-28-1083	78.218
Q1-6	TRANSISTOR AF	NPN BC639 TO-92	MOTOROLA	BC639ZL1	28.120
R4-6	RESISTOR MF	390 OHM 5% 0.4W	PHILIPS	2322 181 53391	01.189
R5-6	RESISTOR MF	1k0 OHM 5% 0.4W	PHILIPS	2322 181 53102	01.200
R6-6	RESISTOR MF	4k7 OHM 5% 0.33W	PHILIPS	2322 187 73472	02.488
R7-6	RESISTOR MF	10k OHM 5% 0.33W	PHILIPS	2322 187 73103	02.496
RE1-6	RELAY 12VDC DPDT 1.25A	M1B-12-H/AZ 820-2C212DE	MEISEI	M1B-12-H	21.295
RE2-6	RELAY 12VDC 1A 1 SHIFT	V23026-A1002-B201	SIEMENS	V23026-A1002-B201	21.029
S1-6	SWITCH TOGGLE DPDT	ON-NONE-ON PCB VERSION	C&K	7201-S-Y-C-Q-E	43.018
ST1-6	TERMINAL BLOCK	10 POLES 1.5mm2	PTR	AK300/10b m.MESS.SKRUER	81.017
ST2-6	TERMINAL BLOCK	16 POLES 1.5mm2	PTR	AK300/16b m.MESS.SKRUER	81.014
ST3-6	TERMINAL BLOCK	14 POLES 1.5mm2	PTR	AK300/14b m.MESS.SKRUER	81.029
ST4-6	TERMINAL BLOCK	SINGLE POLE	RIACON	360291	81.028
ST5-6	TERMINAL BLOCK	3 POLES 1.5mm2	PTR	AK500/3DS-5.0V*M	81.008
ST7-6	TERMINAL BLOCK	10 POLES 1.5mm2	PTR	AK300/10b m.MESS.SKRUER	81.017
TR1-6	TRAFO AF	1:1 600 OHMS	TDK	L04EE13-C10153	22.500
TR2-6	TRAFO AF	1:1 600 OHMS	TDK	L04EE13-C10153	22.500